

FEATURES

- 4 configurable outputs: shutter channels (up to 2), individual outputs (up to 4) and 2-pipe fan coil control (up to 1)
- Outputs suitable for capacitive loads, maximum 140 µF.
- Manual output operation with push button and LED Status indicator.
- 10 logic functions.
- Output timing.
- Total data saving on KNX bus failure.
- Integrated KNX BCU.
- Dimensions 67 x 90 x 35 mm (2 DIN units).
- DIN rail mounting (EN 50022), with fixing clamp.
- Possibility of connecting different phases in adjacent outputs.
- Conformity with the CE directives (CE-mark on the right side).

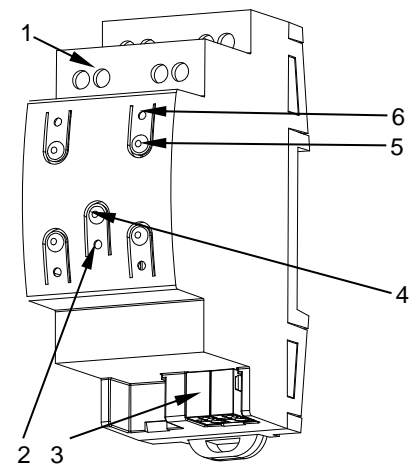

Figure 1: MINiBOX 40 v2

1. Upper outputs	2. Programming/test LED	3. KNX Connector
4. Programming/test button	5. Output control button	6. Output status LED indicator

Programming/Test button: short press to set programming mode. If this button is held while plugging the device into the KNX bus, it enters the safe mode. If this button is held for more than 3 seconds, the device enters the test mode.

Programming/Test LED: programming mode indicator (red). When the device enters the safe mode, it blinks (red) every half second. The manual mode is indicated by the green color. During the start-up (reset or after KNX bus failure) and if the device is not in safe mode, it starts a blue blinking sequence.

GENERAL SPECIFICATIONS				
CONCEPT		DESCRIPTION		
Type of device		Electric operation control device		
KNX supply	Voltage (typical)	29VDC SELV		
	Voltage range	21..31VDC		
	Maximum consumption	Voltage	mA	mW
		29VDC (typical)	4	116
24VDC ¹	10	240		
Connection type		Typical TP1 bus connector for 0.80mm Ø rigid cable		
External power supply		Not required		
Operation temperature		0°C .. +55°C		
Storage temperature		-20°C .. +55°C		
Operation humidity		5 .. 95%		
Storage humidity		5 .. 95%		
Complementary characteristics		Class B		
Protection class / Overvoltage category		II / III (4000V)		
Operation type		Continuous operation		
Device action type		Type 1		
Electrical stress period		Long		
Degree of protection / Pollution degree		IP20 / 2 (clean environment)		
Installation		Independent device to be mounted inside electrical panels with DIN rail (EN 50022)		
Minimum clearances		Not required		
Response on KNX bus failure		Data saving according to parameterization		
Response on KNX bus restart		Data recovery according to parameterization		
Operation indicator		The programming LED indicates programming mode (red) and test mode (green). Each output LED indicates its status		
Weight		91g		
PCB CTI index		175V		
Housing material / Ball pressure test temperature		PC FR V0 halogen free / 75°C (housing) - 125°C (connectors)		

¹ Maximum consumption in the worst case scenario (KNX Fan-In model)

OUTPUTS SPECIFICATIONS AND CONNECTIONS

CONCEPT		DESCRIPTION
Number of outputs		4
Output type / Disconnection type		Potential-free outputs through bistable relays with tungsten pre-contact / Micro-disconnection
Rated current per output		AC 16(6)A @ 250VAC (4000VA) DC 7A @ 30VDC (210W)
Maximum load per output	Resistive	4000W
	Inductive	1500VA
Maximum inrush current		800A/200µs 165A/20ms
Connections in adjacent outputs		Possibility of connecting different phases. It is not allowed to connect power supplies of different order, SELV with NO SELV, in the same block
Total maximum current in device		40A
Short-circuit protection		NO
Overload protection		NO
Connection method		Screw terminal block
Cable cross-section		0.5-4mm ² (IEC) / 20-12AWG (UL)
Outputs per common		1
Maximum response time		10ms
Mechanical lifetime (min. cycles)		3 000 000
Electrical lifetime (min. cycles) ¹		100000 @ 8A / 25000 @ 16A (VAC)

¹ Lifetime values could change depending on the load type.

WIRING DIAGRAMS

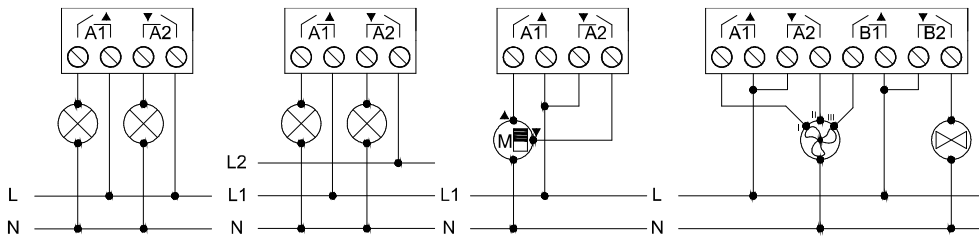

⚠ In order to ensure the expected status of the relays, please check that the device is connected to the KNX bus before energizing the power circuit.

Figure 2: Wiring example (from left to right): 2 loads, 2 loads connected to different phases, shutter and fan coil

Attaching MINiBOX 40 v2 to DIN rail:

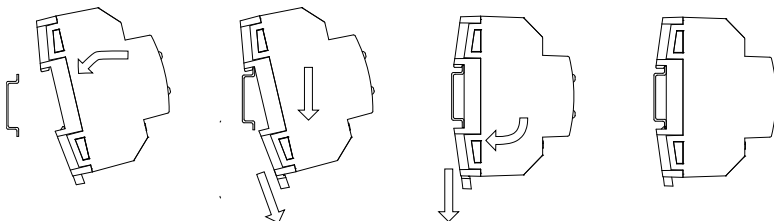

Removing MINiBOX 40 v2 from DIN rail:

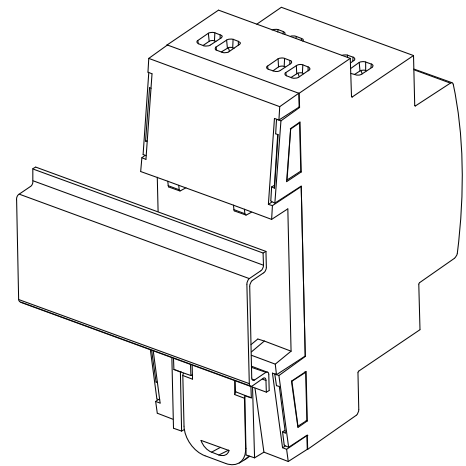
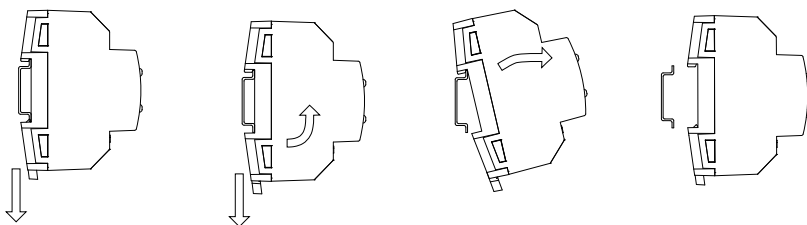

Figure 3: Mounting MINiBOX 40 v2 on DIN rail

SAFETY INSTRUCTIONS



Installation should only be performed by qualified professionals according to the laws and regulations applicable in each country.

- Do not connect the mains voltage nor any other external voltage to any point of the KNX bus; it would represent a risk for the entire KNX system. The facility must have enough insulation between the mains (or auxiliary) voltage and the KNX bus or the wires of other accessories, in case of being installed.
- Once the device is installed (in the panel or box), it must not be accessible from outside.
- Keep the device away from water (condensation over the device included) and do not cover it with clothes, paper or any other material while in use.
- The WEEE logo means that this device contains electronic parts and it must be properly disposed of by following the instructions at <http://zennio.com/weee-regulation>.