

INTRODUCTION

KLIC-DI is an interface that allows a bidirectional communication between a KNX domotic system and the commercial air-conditioning units of the commercial and industrial series.

This device controls all basic functionalities of this type of air conditioning machines as well as it handles AC unit error codes and communication errors that may arise.

MASTER CONTROL VS. SLAVE CONTROL

The great majority of internal units of commercial series and variable refrigerant volume systems are controlled with a wired control that is connected to the terminal P1/P2 available in these units.

KLIC-DI is compatible with the use of wired controls. Nevertheless, it is important to establish one of these controls as master control and the other as slave control. This way, if the wired control is the master, KLIC-DI must be configured as slave in the parameterization of the device and vice versa, if the KLIC-DI is the master control, the wired control must be configured as slave.

Note: For configuring the wired control as master or slave: remove the casing of the control, locate the switch marked as M/S (master/slave) in the PCB and select the position of the switch. This switch is usually located in the lower left-hand corner or in the upper right-hand corner. It is necessary to remove the bus and connect it again in order to set the new configuration.



It is hardly recommended to check the configuration of the wired control when carrying out the installation.

INSTALLATION

KLIC-DI is a device of reduced dimensions (90 x 60 x 35 mm) with two terminals for integrating air conditioning machines of the commercial series and variable refrigerant volume units in a KNX domotic system:

- **EIB connector**, for its connection to KNX system bus.
- **P1/P2 terminal**, for its connection to air-conditioning internal unit through a 2-wired cable with cross-section area lower than 0.75mm².

Nr	Description
1	EIB connector
2	Programming and checking LED. For more information about the color code, look up the manual
3	Programming button
4	2-wire communication terminal

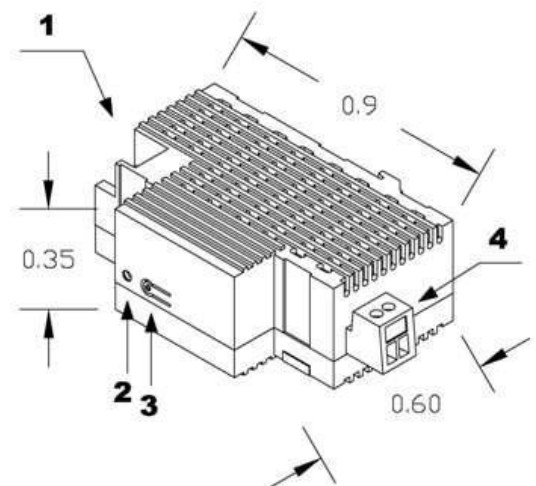

This device does not require any external power supply, since it is fed through the KNX bus.

For installing the KLIC-DI, the device must be connected to KNX bus, through the EIB connector, in the same way as any KNX device.

On the other hand, for connecting the device KLIC-DI to the air-conditioning internal unit, the terminal P1/P2 located in the PCB of the AC unit must be connected to terminal P1/P2 located in one side of the KLIC-DI (this connector is included as accessorize with the device).



If a wired control is included in the installation, the device KLIC-DI can be also connected to the terminal P1/P2 of the wired control.



In order to locate the terminal P1/P2 in the PCB of the wired control, remove the casing of the wired control and look for the terminals marked as P/P1 and N/P2.

Please note: Do not wire KLIC-DI to the air conditioning unit until Daikin installers end the commissioning of the VRV installation.

CONNECTIONS DIAGRAMS

KLIC-DI (master, without wired control in the bus):

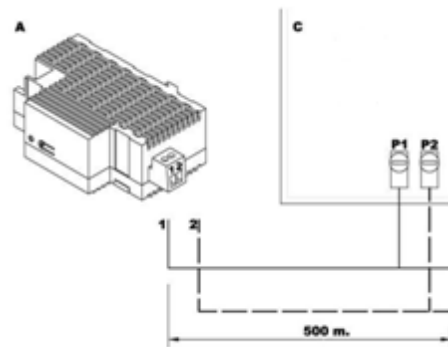

Note: Each KLIC-DI is able to control **only one** internal unit.

It is not possible to connect several internal units in series and control them with KLIC-DI.

KLIC-DI (master/slave) + wired control (slave/master):

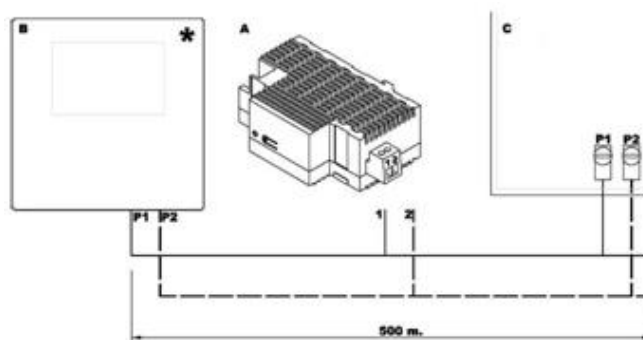

Legend Connection Diagrams	
A	KLIC – DI
B	wired control
C	internal unit
P1- P2	connection bus
1- 2	Zennio's connection terminal
*	The wired control must work as slave when KLIC-DI is master and vice versa

Note: The infrared remote controllers **BRC7*** and **BRC4*** can only work as SLAVE. In case any of these remote controllers are installed, KLIC-DI should be configured as MASTER.

Once the device is powered from the KNX bus, the physical address and the corresponding application program KLIC-DI can be downloaded.

SPECIAL INSTALLATIONS CASES

Variable refrigerant volume system without sin Heat Recovery Unit

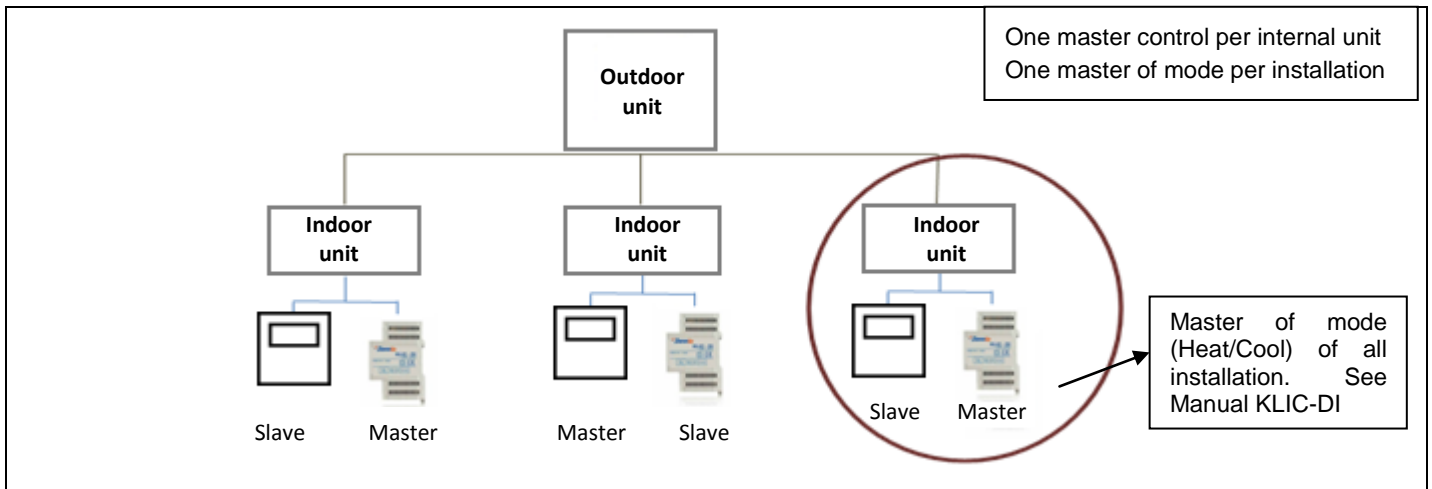

Variable refrigerant volume system of 3 pipes with Heat recovery unit

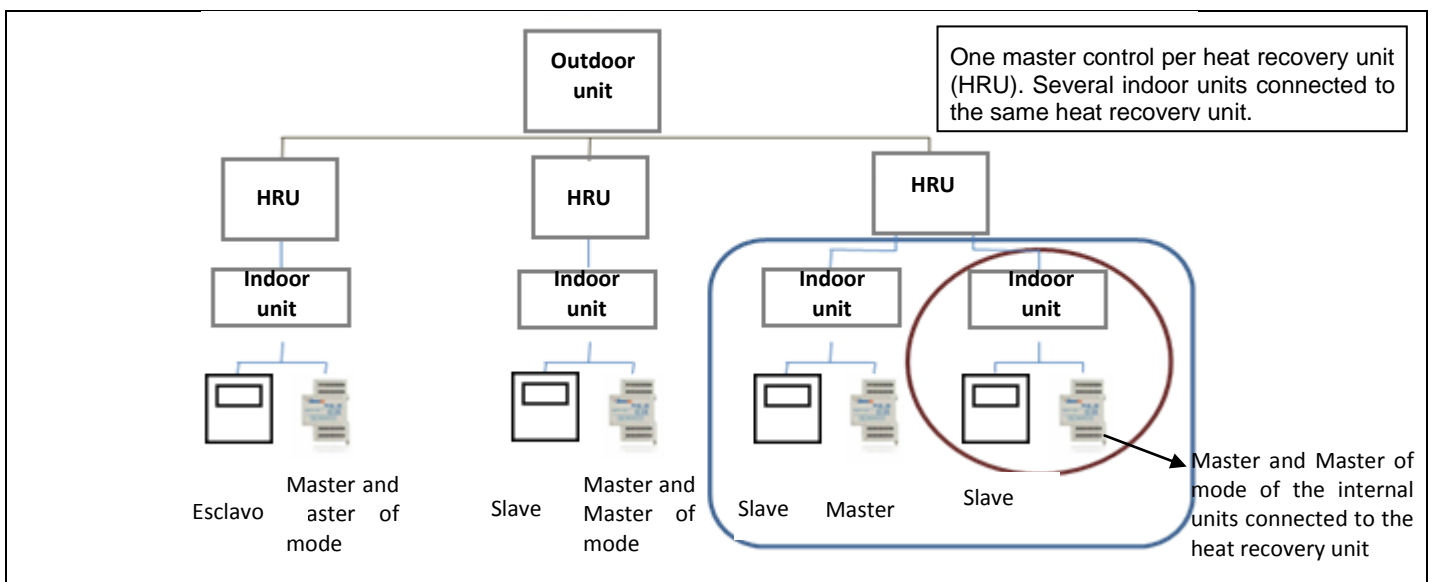

Warning Connection in Series

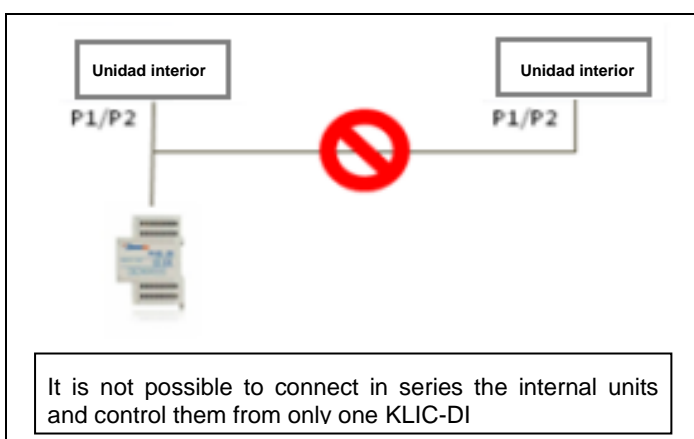

Recommendation for joint control of units

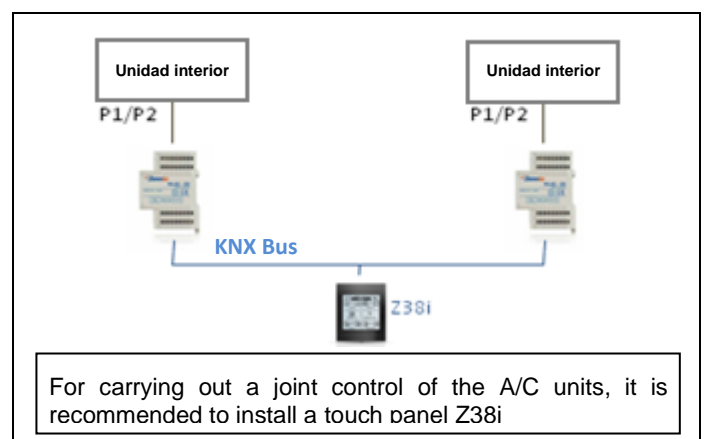

CENTRAL CONTROL OF AC UNITS

KLIC-DI can be used with a Daikin central control for monitoring only. In case the Daikin central control is used as a controller of the Daikin system, there might be incompatibilities.

AIR TEMPERATURE REGULATION – AC UNIT FUNCTIONING

Air conditioning units carry out a regulation of the airflow temperature according with the setpoint temperature they receive and a reference temperature, which is measured by a temperature probe in the air conditioning system. In AC systems, this reference temperature is provided by **the indoor unit internal temperature probe**, the **wired remote temperature probe** or **a temperature probe connected to the indoor unit** (placed in the room).

Note: It is not recommended to perform a thermostatic control to switch on/off of the AC unit. It influences negatively over its operation.

Thanks to **KLIC-DI**, a **temperature that is received from KNX bus** can be used as reference temperature instead of the wired remote controller temperature probe. The installer must select the wired remote controller as reference temperature and KLIC-DI as master.

Thus, the possible reference temperatures for regulation of airflow temperature are:

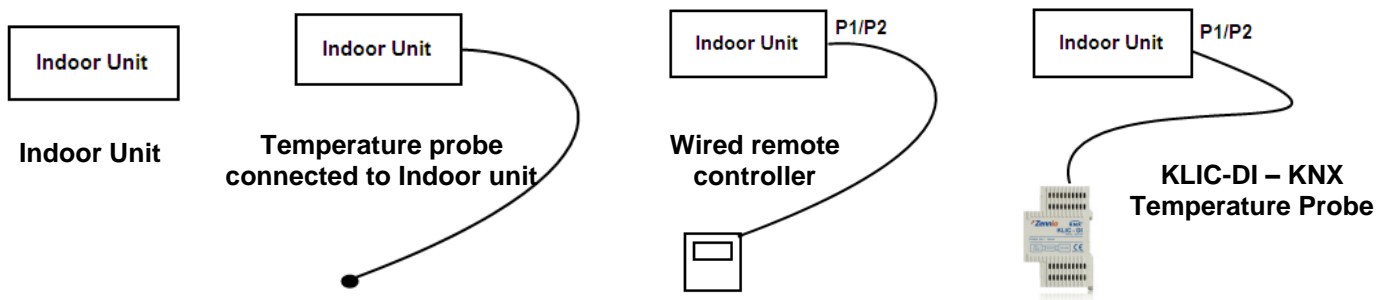

In any of the cases above there are some **temperature ranges** that establish whether the temperature probe of the indoor unit or one of the other external temperatures are used. These ranges depend on the difference between setpoint temperature and the temperature measured by the indoor unit probe, as well as the indoor unit working mode (heating/cooling):

Indoor unit cooling

When the **real temperature is lower than setpoint and rises above it** (due to an external process of heating), reference temperature is:

- Indoor unit temperature probe, UP TO 1°C below the setpoint.
- External temperature probe, in a range BETWEEN 1°C below and 3°C above the setpoint.
- Indoor unit temperature probe, FROM 3°C above the setpoint.

When the **real temperature is higher than setpoint and drops below it**, reference temperature is:

- Indoor unit temperature probe, UP TO 1°C above the setpoint.
- External temperature probe, in a range BETWEEN 1°C above and 3°C below the setpoint.
- Indoor unit temperature probe, FROM 3°C below the setpoint.

Indoor unit heating (air in the room is usually cooler than the one that is pumped by the indoor unit)

When the **real temperature is below the setpoint and it rises above it** reference temperature is:

- Indoor unit temperature probe, UP TO 1°C above the setpoint.
- External temperature probe, FROM 1°C above the setpoint.

When the **real temperature is above the setpoint and it drops below it** (due to an external process of cooling), reference temperature is:

- External temperature probe, UP TO 1°C below the setpoint.
- Indoor unit temperature probe, FROM 1°C below the setpoint.

