



# DALIBOX Interface 64/32

KNX-DALI Interface for 64 devices / 32 groups

ZDI-DLI

Application Program Version: [1.3]

Manual Edition: [1.3]\_b

[www.zennio.com](http://www.zennio.com)

# CONTENTS

---

1	Introduction .....	5
1.1	DALIBOX Interface 64/32 .....	5
1.2	Installation.....	7
1.3	Compatible Ballasts.....	9
2	Configuration.....	11
2.1	General Configuration.....	13
2.1.1	Error Objects.....	16
2.1.2	Standby Mode.....	20
2.2	Enabling Ballasts.....	23
2.3	Enabling Groups .....	25
2.4	No Group.....	26
2.4.1	ECG N .....	26
2.5	Group N.....	28
2.5.1	Configuration .....	28
2.5.2	ECG M .....	30
2.5.3	Limits.....	30
2.5.4	Switch & Dimming .....	32
2.5.5	Status Objects .....	34
2.5.6	Custom On/Off.....	35
2.5.7	Timers .....	36
2.5.8	Lock.....	42
2.5.9	Custom Initialisation .....	43
2.5.10	Modes.....	44
2.6	Scenes.....	48
2.6.1	Configuration .....	48
2.6.2	Scene N .....	49
2.7	Sequences .....	50
2.7.1	Configuration .....	50
2.7.2	Sequence N .....	51
2.8	Display .....	54

2.8.1 Main Menu ..... 54

2.8.2 Installation ..... 54

2.8.3 Reset All ECGs ..... 58

2.8.4 Manual Control ..... 59

2.8.5 Scene Control ..... 60

2.8.6 Burn-in Control ..... 60

2.8.7 Application Version ..... 61

Annex I. Communication Objects ..... 62

## DOCUMENT UPDATES

---

Version	Changes	Page(s)
[1.3]_b	Clarification about ballast change directions.	17
[1.3]_a	<b>Changes in the application program:</b> <ul style="list-style-type: none"> <li>New parameter to configure bit timing.</li> </ul>	-
	New parameter to configure bit timing.	15
	Note about the Burn-in function combined with the option to prevent group assignment overwriting.	47
[1.2]_a	<b>Changes in the application program:</b> <ul style="list-style-type: none"> <li>New parameter to preserve group configurations after downloads.</li> </ul>	-

# 1 INTRODUCTION

---

## 1.1 DALIBOX INTERFACE 64/32

---

**DALIBOX Interface 64/32** from Zennio is a KNX-DALI gateway that allows controlling, dimming and monitoring up to 64 ballasts (in up to 32 groups) in a DALI bus by means of KNX communication objects, which makes it possible to integrate the DALI installation into the building automation system.

Their main functions are:

- **General ballast control** through universal DALI commands.
- Support for **up to 64 DALI ballasts** in total,
- **110V** or **230V** power supply.
- Ballast control **by groups** (up to 32).
- **Ballast swap** with automatic address re-assignment.
- Light regulation with **customisable dimming** limits and times, or by manually characterising the dimming curve.
- **Lock** function.
- **Timed actions**: simple timers, flashing sequences and automatic switch-off.
- **Scenes** and **sequences**.
- **Custom On/Off** controls.
- **Standby Mode** to help save power consumption in the ballasts by controlling the power supply to the output groups.
- **Error detection and notification**.
- Support for the **Burn-in** mode, required by certain lamps during the switch-on in order to ensure an optimal life period.

- **Test mode and manual configuration of the DALI installation** through the on-board display and pushbuttons.
- **Heartbeat** or periodical “still-alive” notification.

## 1.2 INSTALLATION

**DALIBOX Interface 64/32** connects to the KNX bus through the on-board KNX connector. Once the device is provided with power from the KNX bus, both the individual address and the associated application program can be downloaded.

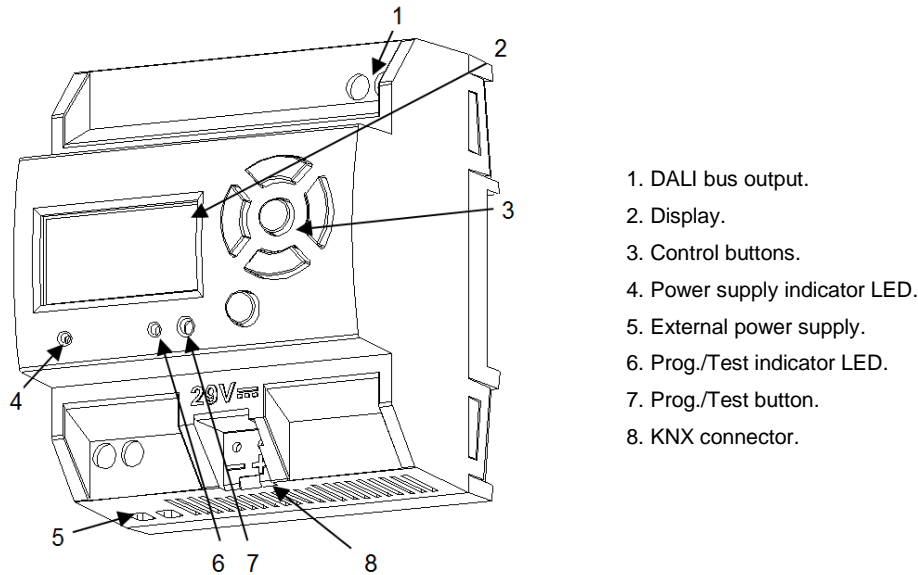

Figure 1. Element Diagram.

The main elements of the device are described next:

- **Prog./Test button (7):** a short press on this button sets the device into the programming mode, making the associated LED (6) light in red.

**Note:** if this button is held while plugging the device into the KNX bus, the device will enter into **safe mode**. In such case, the LED will blink in red every 0.5 seconds.

- **DALI bus output (1):** slot for the connection of the DALI bus wires.
- **Neutral and Phase Inputs (5):** slots for the connection of the neutral and the phase of the power line.
- **Display (2):** 128x64-pixel screen that provides information about the device and the DALI system and allows the execution of different actions.
- **Control buttons (3):** directional arrows (←↑→↓), confirmation button (**OK**) and exit button (**ESC**) that allow browsing through the options on the display.

To get detailed information about the technical features of the device, as well as on the installation and security procedures, please refer to the corresponding **Datasheet**, bundled with the original package of the device and also available at [www.zennio.com](http://www.zennio.com).



## 1.3 COMPATIBLE BALLASTS

**DALIBOX Interface 64/32** is able to control DALI-certified ballasts (i.e., with the DALI logo) that make use of only one individual address. Specifically, it is designed to be compatible with types 0, 2, 3, 4, 5, 6 and 7 of the DALI device type classification, shown in Table 1. Please note that future versions of the application program may support additional ballast types.

Device type	Particular requirements for control gear	Defined in
0	Fluorescent lamps	IEC 62386-201
1	Self-contained emergency lighting	IEC 62386-202
2	Discharge lamps (excluding fluorescent lamps)	IEC 62386-203
3	Low voltage halogen lamps	IEC 62386-204
4	Supply Voltage controller for incandescent lamps	IEC 62386-205
5	Conversion from digital into D.C. voltage	IEC 62386-206
6	LED modules	IEC 62386-207
7	Switching function	IEC 62386-208
8	Colour control	IEC 62386-209
9	Sequencer	IEC 62386-210
10	Optical control	IEC 62386-211
11 to 127	Not yet defined	
128 to 254	Reserved for control devices	
255	Control gear supports more than one device type	

Table 1. DALI device type classification.

Proper operation cannot be guaranteed for other ballasts.

Nevertheless, not all DALI-certified ballasts behave the same way – certain particularities apply:

- Ballasts with LED loads do not report lamp failures; therefore, with these ballasts it is not possible to notify such circumstance to the KNX bus.
- When a lamp failure takes place, certain ballasts with fluorescent lamps may cause the remaining lamps flash briefly.
- Fluorescent-lamp ballasts need an extra time to switch off the load when a non-immediate regulation to 0% is commanded.
- Certain ballast models, on the event of a DALI communication error (e.g., short-circuit or power failure), do not switch to the dimming value configured

for such circumstance – the ballast will maintain the last dimming value that may have been set.

- Some lamps may implement a significant delay when they are switched on. Such circumstance must be taken into account in case of parameterising timed actions or flashing and dimming sequences.
- The ability to report ballast errors will depend on the ballast itself. The documentation provided by the manufacturer should indicate whether such functionality is available or not.

There may be some other (minor) particularities depending on the ballasts and on the lamps in the installation. Therefore, the integrator is advised to perform some testing to ensure compatibility.

***Recommendation:*** *it is advisable to install only one ballast type within the same group in order to avoid ballast control issues.*

## 2 CONFIGURATION

---

The **DALIBOX Interface 64/32** application program allows controlling up to 64 DALI ballasts divided into up to 32 groups. Such control is performed according to a set of customisable options which make DALIBOX Interface 64/32 a very versatile device:

- Different alternatives to **control the luminosity** of the connected loads:
  - One-bit objects to **switch on / switch off** each group,
  - Four-bit objects for per-group **step dimming**,
  - One-byte (percentage) objects for **absolute dimming** (per group).
- **General dimming** features:
  - Configurable **dimming times**, being possible to modify them through communication objects. Up to three different dimming times are available.
  - Dimming limits, i.e., **maximum and minimum lighting** levels.
  - Minimum luminosity level reachable by each group, i.e., the **ballast physical minimum**.
  - Maximum luminosity level allowed in the ballasts under the **economy mode**.
  - **Standby**: mode that allows an external actuator to interrupt the power supply to the ballasts after switching off the loads, thus reducing the power consumption.
- **Custom on/off**: possibility of enabling and configuring different switch-on/off controls for each group, with custom dimming values and times.
- **Simple timer and flashing**: timed switch-on and switch-off sequences of the ballasts connected to the device.
- **Scenes**: up to 32 different customisable scenes, which can be simultaneously associated to different groups.

- **Sequences:** up to 16 different sequences, which can be associated to different groups. Up to five step actions per sequence can be defined, as well as the dimming type of each step action among other things.
- **Lock:** group control enabling/disabling, with the additional option to define actions for the lock and unlock events.
- **Initialisation:** custom configuration of the initial status (upon the recovery of the KNX bus power or after an ETS download or a restart) for each group, or either of an initial sending (immediate or delayed) of the status to the bus.
- **Error identification:** detection of anomalies that may affect the proper operation of the device: power supply error, short circuit, ballast presence error or ballast and group diagnostic errors.
- **Special operation modes:**
  - **Auto Off:** mode that allows automatically switching off a group in case it remains steady under a certain parameterisable dimming threshold for more than a defined time period.
  - **Burn-in:** mode that prevents the execution of dimming orders during a certain, parameterisable time period after the switch-on of the ballast, with the aim of stabilising the lamp response and of optimising its life time. This feature may be required by certain lamp models.

Other than these functions, the general settings of the device allow enabling each of the **64 ballasts (or ECGs)** supported as maximum and assigning it, if desired, any of the **32 groups** available.

## 2.1 GENERAL CONFIGURATION

---

The general configuration of DALIBOX Interface 64/32 basically consists in defining the **dimming times**. They are the length of the transition from switched off (0%) to the maximum luminosity level (100%), which determines the speed of the regulation. **Up to three different dimming times** can be applied to the different orders or actions, and their values may be changed through three communication objects (one per each dimming time).

In case of configuring **dimming limits** (see section 2.5.3), the dimming times will be applied as follows:

- Transitions between 0% and the minimum dimming value will be instantaneous.
- Transitions between the minimum dimming value and the maximum dimming value will take the proportional part of the parameterised dimming time (which must be understood as the time corresponding to the entire transition from 0% to 100%).

Moreover, the general configuration allows enabling the following functions:

- **Scenes**. See section 2.6.
- **Sequences**. See section 2.7.
- **Error Objects**. See section 2.1.1.
- **Standby**. See section 2.1.2.
- **Heartbeat** or periodical “still-alive” notification.
- **Standard Bit Timing**: this function allows customising the time threshold after which the arrival of a new bit through the DALI bus will be considered as corrupt, for instance to prevent telegram collisions in case several ballast have been assigned the same address. Preserving the standard threshold is highly encouraged, unless intending to connect very specific ballasts that may require modifying it.

## ETS PARAMETERISATION

After importing the corresponding ETS database and adding the device to the project topology, the configuration process begins by entering the Parameters tab of the device.

The tab tree on the left shows the “**General**” tab in the first place. This entry itself comprises the following parameters:

Section	Parameter	Value/Status
DIMMING TIMES	Dimming Time 1	5 (s)
	Dimming Time 2	10 (s)
	Dimming Time 3	15 (s)
	Dimming Time Objects	<input type="checkbox"/>
INDEPENDENT FUNCTIONS	Scenes	<input type="checkbox"/>
	Sequences	<input type="checkbox"/>
GENERAL FUNCTIONS	Error Objects	<input type="checkbox"/>
	Standby	<input type="checkbox"/>
	Heartbeat (Periodical Alive Notification)	<input type="checkbox"/>
	Standard Bit Timing	<input checked="" type="checkbox"/>

Figure 2. General

- **Dimming Times:** three dimming times may be parameterised, through the following parameters:
  - **Dimming Time [n]:** sets dimming time  $n$  (1-3), between 1 and 255 (seconds or minutes).
  - **Dimming Time Objects:** enables three general two-byte objects, named “**Dimming Time  $n$** ”, which allow changing the dimming times parameterised (between 1 and 255 minutes or seconds). This parameter is disabled by default.

- **Independent Functions:**

- **Scenes:** see section 2.6.
- **Sequences:** see section 2.7.

- **General Functions:**

- **Error Objects:** see section 2.1.1.
- **Standby:** allows enabling the Standby function. See section 2.1.2.
- **Heartbeat (Periodical Alive Notification):** this parameter lets the integrator incorporate a one-bit object to the project (“**[Heartbeat] Object to Send ‘1’**”) that will be sent periodically with a value of “1” to notify that the device is still working (still *alive*).

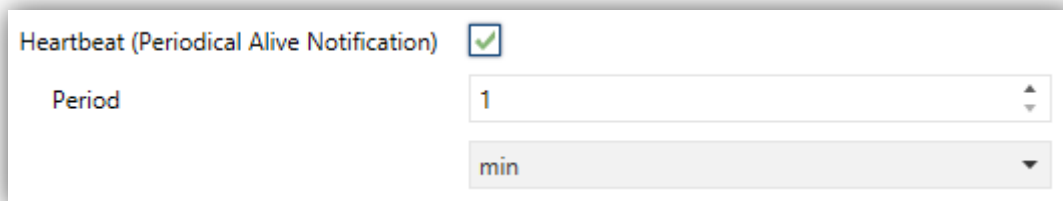

Heartbeat (Periodical Alive Notification)

Period

Figure 3. Heartbeat.

**Note:** *The first sending after download or bus failure takes place with a delay of up to 255 seconds, to prevent bus overload. The following sendings match the period set.*

- **Standard bit timing:** allows enabling or disabling the manual configuration of the bit detection time. The standard value set by default is 500  $\mu$ s.
- **Maximum time for one bit phase:** sets the new threshold value between 500  $\mu$ s and 650  $\mu$ s.

**Note:** *preserving the standard threshold is highly encouraged, unless intending to connect very specific ballasts that may require modifying it.*

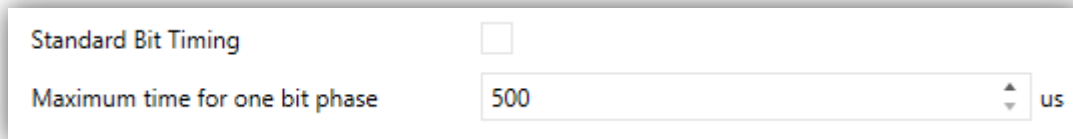

Standard Bit Timing	<input type="checkbox"/>
Maximum time for one bit phase	500 us

Figure 4. Standard Bit Timing.

### 2.1.1 ERROR OBJECTS

DALIBOX Interface 64/32 is able to **detect certain errors** that may occur during normal operation, which will be indicated through the display (section 2.8) or reported to the KNX bus (periodically every minute), if configured.

- The **short-circuit error** is reported in case the communication is interrupted due to issues on the DALI bus. In such cases, the ballasts will acquire the value configured for DALI bus failure cases (see section 2.5.1).

**While this error persists, the following errors will no longer be notified**, due to a lack of communication with the ballasts:

- ECG presence error (see below).
  - ECG and group diagnostic (see below).
- The **DALI power supply error** is reported when the external power supply is interrupted and therefore the DALI bus becomes non-functional. In such case, the ballasts will adopt the level configured for DALI bus failure cases (see section 2.5.1), as the ballasts have their own power supply. In case this is interrupted too, they will obviously switch off.

**During the power supply error, control actions will be ignored.** Other error types will not be reported, either. Nevertheless, the lock objects (see section 2.5.8) will be taken into account so once the error is over the corresponding action can be performed.

- The **ECG presence error** is notified when at least one of the already-detected ballasts no longer responds. The detection of this error may not be immediate, being it possible that the device takes up to one minute to report it. If a regulation order is sent to a ballast whose presence error has not been detected yet, the order will not be executed and one of the following will take place:



- If the error is solved before having been detected, the ballast will remain under a wrong regulation value until the next regulation order.
- If the error is finally detected, once it is solved the ballast will be regulated to the last value received from the KNX bus.

**Important:**

- **To let reducing the number of ballasts in the installation** (which may cause a permanent ballast presence error), the Write flag of the communication object that reports this error has been enabled, so the error can be cleared by sending it the value "0". Whenever this happens, the device will assume the current number of ballasts as correct. This can also be done via the display, as detailed in section 2.8.
- **To replace a defective ballast**, please proceed as follows:
  1. Disconnect the defective ballast keeping DALIBOX Interface on.
  2. Wait for the detection of the ECG presence error (which may take up to 70 seconds).
  3. Clear the ballast presence error (via object or display).
  4. Connect the new ballast (it will be assigned the first DALI address available).
  5. Assign the new ballast the address of the removed ballast.

If, despite following these steps, the new ballast is not detected correctly or is not well configured, disconnect it for at least one minute and reconnect it. Thus DALIBOX Interface will reconfigure it.

**Note:** *in case an open circuit takes place (either due to the disconnection of the DALI bus or to a general power failure of the ballasts), DALIBOX Interface 64/32 will report an ECG presence error for each ballast.*

- The **diagnostic errors** are errors detected by the ballasts themselves. DALIBOX Interface 64/32 is informed about them when it requests the status from the ballast.
  - **ECG Failure:** the ballast cannot operate normally. The reasons that cause this error depend on the manufacturer.

- **Lamp failure:** the lamp cannot be switched on normally, either due to a defect (burned-out bulb) or to an incorrect connection.

**Note:** *the dimming level must be higher than 0% in order to detect the lamp failure error. Otherwise, even if the lamp is burnt out, the ECG will not be able to detect it.*

Note that in case the ballast does not implement this function, DALIBOX Interface 64/32 will not be able to report these errors (see section 1.3).

**Blocking errors (short-circuit and lack of power supply) will interrupt all actions, including timed actions.** Other errors will not interrupt them – they will still be executed by all connected ballasts that do not present errors.

---

## ETS PARAMETERISATION

---

The Error Objects function can be parameterised from the “**General**” tab. Once enabled through its own checkbox, the following options become available:

GENERAL FUNCTIONS	
Error Objects	<input checked="" type="checkbox"/>
DALI Power Supply	<input type="checkbox"/>
Short Circuit	<input type="checkbox"/>
ECG Presence	<input type="checkbox"/>
Diagnostic	-
Standby	-
Heartbeat (Periodical Alive Notification)	ECG Diagnostic (1 byte)
	ECG and Group Diagnostic (2 bytes)

Figure 5. Error Objects

- **Short Circuit Error:** enables the “**Error: Short Circuit**” object, which will be sent with a value of “1” in case of detecting communication errors or a short circuit in the DALI bus. After the error is over, it will be sent once with a value of “0”.
- **DALI Power Supply:** enables a one-bit object (“**Error: DALI Power Supply**”) that will notify the existence of a power supply failure in the device by sending a value of “1”. Once the error is over, it will send a value of “0”.

- **ECG Presence:** enables the “**Error: ECG Presence**” object, which will be sent with a value of “1” in case of detecting a ballast presence failure. After the error is over, it will be sent once with a value of “0”.
- **Diagnostic:** enables the diagnostic errors function, which allows DALIBOX Interface 64/32 forwarding to the KNX bus any ECG errors and lamp errors it may obtain from the ballasts. The object type for these sendings must be configured:
  - ECG Diagnostic (1 byte): object with DPT [238.600].
  - ECG and Group Diagnostic (2 bytes): object with DPT [237.600].

Object	DPT	Format											
<b>ECG Diagnostic</b>	[238.600]	<table border="1" style="display: inline-table; vertical-align: middle;"> <tr> <td style="width: 20px; text-align: center;">BF</td> <td style="width: 20px; text-align: center;">LF</td> <td style="width: 60px; text-align: center;">Addr</td> </tr> </table> <p> <b>BF:</b> set to “1” in case of ECG failure (“0” in another case).  <b>LF:</b> set to “1” in case of lamp failure (“0” in another case).  <b>Addr:</b> address of the ballast.                 </p>	BF	LF	Addr								
BF	LF	Addr											
<b>ECG and Group Diagnostic</b>	[237.600]	<table border="1" style="display: inline-table; vertical-align: middle;"> <tr> <td style="width: 15px; text-align: center;">r</td> <td style="width: 15px; text-align: center;">r</td> <td style="width: 15px; text-align: center;">r</td> <td style="width: 15px; text-align: center;">r</td> <td style="width: 15px; text-align: center;">r</td> <td style="width: 15px; text-align: center;">CE</td> <td style="width: 15px; text-align: center;">BF</td> <td style="width: 15px; text-align: center;">LF</td> <td style="width: 20px; text-align: center;">RR</td> <td style="width: 20px; text-align: center;">AI</td> <td style="width: 60px; text-align: center;">Addr</td> </tr> </table> <p> <b>BF:</b> set to “1” in case of ECG failure (“0” in another case).  <b>LF:</b> set to “1” in case of lamp failure (“0” in another case).  <b>RR:</b> set to “1” on requests and to “0” on responses.  <b>AI:</b> set to “1” for groups and to “0” for ballasts.  <b>Addr:</b> address of the ballast (0-63) or of the group (0-31).  <b>r:</b> bits set to “0”.                 </p> <p> <b>Note:</b> notification of converter failures (CE) is not available in DALIBOX Interface 64/32.                 </p>	r	r	r	r	r	CE	BF	LF	RR	AI	Addr
r	r	r	r	r	CE	BF	LF	RR	AI	Addr			

**Table 2.** DPT specification (238.600 and 237.600).

Regardless of the selected type, the object will be automatically sent as soon as DALIBOX Interface 64/32 is notified about the occurrence of any of these errors in any of the ballasts. The error type and ballast address are coded in the object value, according to the specification of the DPTs.

On the other hand:

- The **Read flag** of the one-byte object has been enabled so it can receive read requests any time. The information returned by the object is always referred to the last ballast that presented an error.
- The **Write flag** of the two-byte object has been enabled so it can receive requests specifically for a particular ballast or group.

Although the two-byte object admits requesting information about a specific group, all automatic sendings will always be referred to ballasts.

### 2.1.2 STANDBY MODE

When enabled, DALIBOX Interface 64/32 sends a one-bit object to the KNX bus thirty seconds after every group is switched off. This allows making use of an external actuator to interrupt the power supply of the ballasts, thus reducing the power consumption. The object will be sent once again (with the inverse value) as soon as the group is switched on again. Note that enabling this function may make the group switch-on last a little longer than expected.

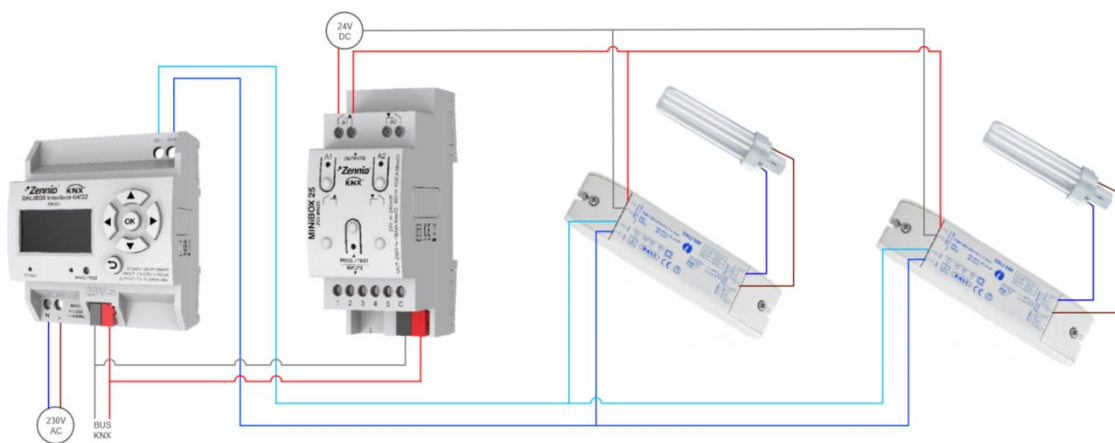

**Figure 6.** Wiring suggestion for the Standby function

On the other hand, during the device **start-up**, the Standby object will be sent as **inactive** to make it possible that the ballasts are powered during their initialisation. Some other situations imply sending the Standby object:

- A power supply error,
- A short-circuit error,

- **The Burn-In mode** (see section 2.5.10.1). If the Standby function has been enabled, the Burn-In mode will last 600 ms longer, to ensure the ballasts are powered for at least the parameterised burn-in time.
- **The Test On mode** (see section 2.8.4).

It is important to note that this functionality may have certain consequences over ballast replacements or group error detections. For example:

- While the Standby mode remains active (i.e., while the ballast power supply remains interrupted), **DALI-related errors** such as the ballast presence error or the diagnostic errors will no longer be detected.
- During **ballast initialisation** or DALI address assignment, any attempts to activate the Standby mode will be postponed by 30 seconds, as many times as necessary until such process is finished.

The following example illustrates how the Standby mode works:

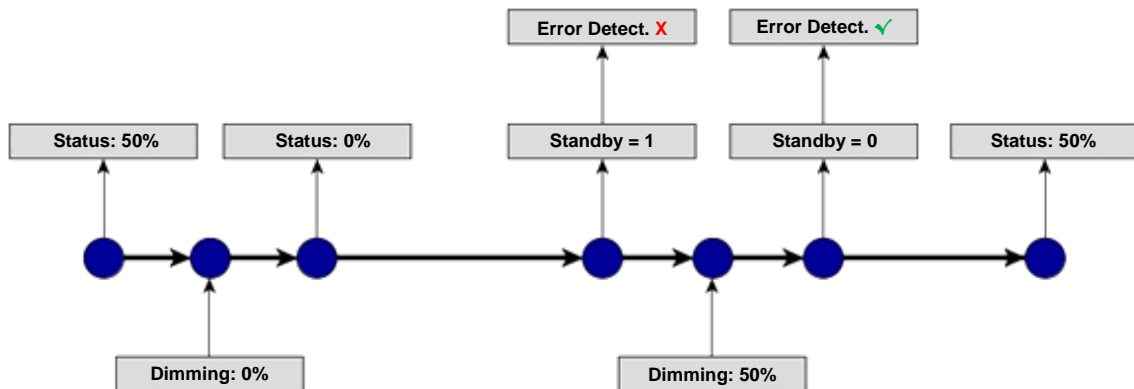

Figure 7. Standby mode action sequence

**Important:** ballasts with no group assignment (see section 2.2) should not be connected to the actuator that interrupts the power supply, as they may cause a ballast presence error notification when the Standby mode gets activated.

---

**ETS PARAMETERISATION**

---

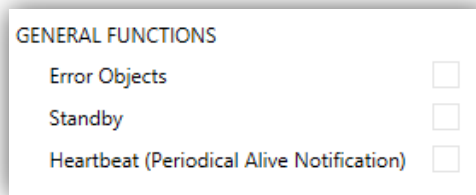

**Figure 8.** General functions

Once the Standby function is enabled from the General Functions section in the “**General**” parameter tab, the following parameter becomes available:

- **Standby Object Polarity:** sets value will be sent through “**Standby (Status)**” on the activation and the deactivation of the Standby mode: “0 = Standby Off; 1 = Standby On” or “0 = Standby On; 1 = Standby Off”.

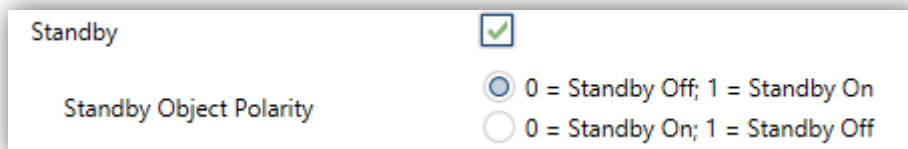

**Figure 9.** Standby

## 2.2 ENABLING BALLASTS

Once the general configuration has been defined, it is possible to enable each of the ballasts and assign it, if desired, a specific group according to the number of loads to be controlled and their distribution along the DALI installation. In case this assignment had already been performed, successive downloads will overwrite it or not according to the parameterisation.

DALIBOX Interface 64/32 can control up to 64 ballasts, distributed along up to 32 groups. Bear in mind that ballasts can still be configured even if they are not assigned any group (which can be manually done afterwards, by means of the display).

Note that for **groups 17 through 32** only one ballast can be assigned per group, whereas groups **1 through 16** may contain several ballasts.

### ETS PARAMETERISATION

The “**Enable ECGs**” tab allows enabling each of the ballasts and optionally assigning them a group, according to the following parameters:

GENERAL	ENABLE ECGS
<b>ENABLE ECGS</b>	Overwrite groups assignment when downloading <input type="checkbox"/>
<b>ENABLE GROUPS</b>	After download the groups and ballasts assignment carried out previously will be kept
	Enable ECG 1 <input type="checkbox"/>
	Enable ECG 2 <input type="checkbox"/>
	Enable ECG 3 <input type="checkbox"/>
	Enable ECG 4 <input type="checkbox"/>
	Enable ECG 5 <input type="checkbox"/>
	Enable ECG 6 <input type="checkbox"/>
	Enable ECG 7 <input type="checkbox"/>
	Enable ECG 8 <input type="checkbox"/>
	Enable ECG 9 <input type="checkbox"/>
	Enable ECG 10 <input type="checkbox"/>

Figure 10. Enabling ECGs

- **Overwrite group assignment when downloading:** sets whether the group assignments of the ballasts should be overwritten after downloading the new

parameterisation, or maintained in case it had already been performed (either through previous parameter downloads or by means of the on-board controls and display).

In case this option is left **disabled**, the following parameter is shown:

- **Enable ECG N:** sets which ballasts will remain enabled. Note that, although they may have been assigned a group previously, they will be shown under the “No group” tab (see section 2.4).

On the other hand, if **enabled**, the following parameter is shown:

- **ECG N Group Assignment:** sets which ballasts will remain enabled and, optionally, the group assigned to each of them:
  - “–”: ballast N is disabled.
  - “No Group”: ballast N is enabled but has no group assigned.
  - “Group Y”: ballast N is enabled and associated to group Y.

**Note:** *groups 17 – 32 are one-ballast groups.*

**Important:** *any groups being assigned to ballasts must also be explicitly enabled. See section 2.3.*

A specific sub-tab will be available per ballast under the tab of the group the ballast belongs to. See section 2.5.2.



## 2.3 ENABLING GROUPS

---

Any group containing at least one ballast (or that may contain it after later assignments performed via the display of the device) must be explicitly enabled. Moreover, this makes it possible to configure the desired functions for each group, as described in section 2.5.

---

### ETS PARAMETERISATION

---

The “**Enable Groups**” tab allows enabling each of the groups that may be or may have been assigned to the ballasts.

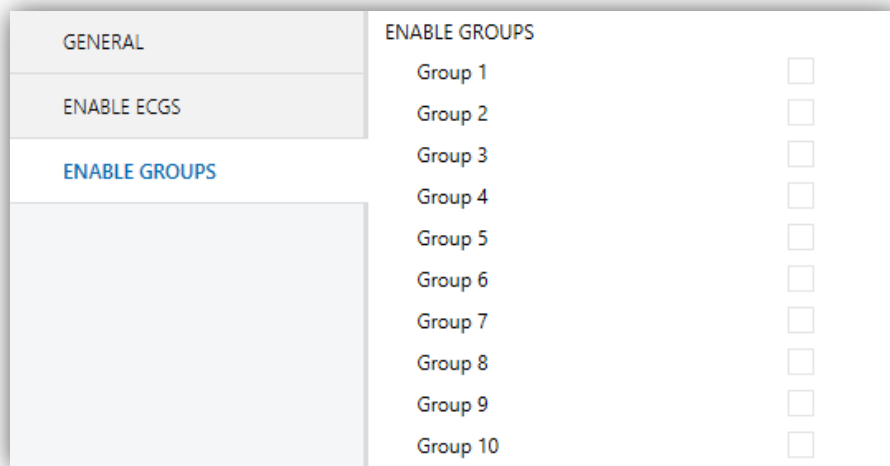

Figure 11. Enabling groups

One checkbox is provided per group. For each enabled group, a new tab named “Group N” (N = 1 to 32) will be incorporated into the tab tree on the left. Please refer to section 2.5 for details.

## 2.4 NO GROUP

### 2.4.1 ECG N

Ballasts that have been enabled but have no group assigned yet will still provide some basic configuration options, analogous to those provided by ballasts that do have a group assigned, although none of the functions that can be configured for groups will be available for ballasts without a group.

These basic options are:

- **Name:** name of up to twelve characters that will identify the ballast along the options of the device display, for example during group assignment or for the manual control function.
- **Operating time counter:** function that informs the KNX bus about the operation time, i.e., how much time the ballast has remained under a dimming level greater than 0% since DALIBOX Interface 64/32 took over the control of the ballast.

### ETS PARAMETERISATION

When new ballasts with no group assignment become enabled (see section 2.2), new sub-tabs (one per ballast) will be incorporated under the “**No Group**” tab, providing the following options:

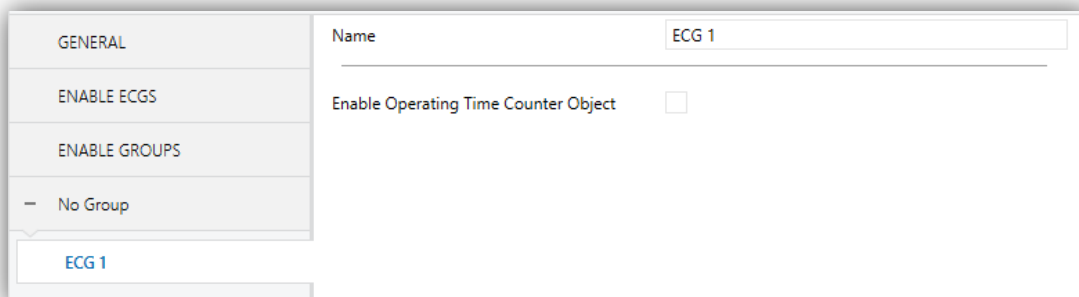

Figure 12. No Group – ECG N

- **Name:** desired identifier for the ballast (up to twelve characters).
- **Enable Operating Time Counter Object:** enables the “[ECG n] Operating Time” four-byte object, which shows (in seconds, although updated every

hour) how much time DALIBOX Interface 64/32 has been regulating the ballast with a dimming level greater than 0%. This object can be overwritten to change the value, for example in case of a ballast replacement. It can also be reset by means of the “Installation” menu on the display, as detailed in section 2.8.

## 2.5 GROUP N

---

### 2.5.1 CONFIGURATION

---

The general configuration for each group involves the following options:

- **Group name:** name of up to twelve characters that will identify the group along the options of the device display.
- **Dimming value during DALI bus failure:** sets the dimming level that will be adopted by the ballasts of the channel if communication errors take place between DALIBOX Interface 64/32 and the ballasts, which may be due to **short-circuits** or to a **power supply failure**.

**Note:** *during the absence of the KNX bus, on the contrary, DALIBOX Interface 64/32 will keep powering the DALI groups (even if the external power LED indicator remains off), thus making the ballasts remain in the last dimming level. Note that timed actions will be stopped and will not be resumed when the KNX bus voltage is recovered.*

- **Functions:** it is possible to configure a set of custom functions per group:
  - **Status objects:** allows enabling or disabling the status objects associated to each channel (On/Off and dimming value). See section 2.5.5.
  - **Custom On/Off:** allows enabling two custom On/Off controls, with different dimming values and times. See section 2.5.6.
  - **Timers:** allows defining timed or delayed on/off switches. See section 2.5.7.
  - **Lock:** enables a lock object, which allows locking and unlocking the group, i.e., disabling the control. See section 2.5.8.
  - **Custom initialisation:** permits setting the initial state of the ballasts in the group (or after a KNX bus failure). See section 2.5.9.
  - **Modes:** allows enabling and configuring different operation modes: Auto Off and Burn-in. See section 2.5.10.

## ETS PARAMETERISATION

As new groups are enabled (see section 2.3), additional sub-tabs will be incorporated with name “Group N”, being N their specific numbers. These tabs, on their side, contain a set of new sub-tabs. The first one, “**Configuration**”, provides the following parameters:

- **Name:** desired identifier for the group (up to twelve characters).
- **Diming Value During DALI Bus Failure:** “No Change” (by default); “Off” (which makes the ballast switch off) or “Defined Value” (the ballast will switch to a customisable value, between 0% and 100%).

GROUP NAME
Name: G1
BUS FAILURE
Dimming Value During DALI Bus Failure: No Change
FUNCTIONS
Status Objects <input checked="" type="checkbox"/>
Custom On/Off <input checked="" type="checkbox"/>
Timers <input checked="" type="checkbox"/>
Lock <input checked="" type="checkbox"/>
Custom Initialization <input checked="" type="checkbox"/>
Modes <input checked="" type="checkbox"/>

Figure 13. Group 'N'. Configuration

- **Functions:** checkboxes to enable additional functions for the group:
  - **Status Objects:** see section 2.5.5
  - **Custom On/Off:** see section 2.5.6
  - **Timers:** see section 2.5.7
  - **Lock:** see section 2.5.8
  - **Custom Initialisation:** see section 2.5.9
  - **Modes:** see section 2.5.10

## 2.5.2 ECG M

Other than the additional functions and options for the group, some specific options will be provided for each of the ballasts that have been enabled and assigned such group. These options are analogous to the basic options available for ballasts with no group assignment. Please refer to section 2.4.1 for more details.

### ETS PARAMETERISATION

When new ballasts become enabled (see section 2.2) and assigned to a group, new sub-tabs (one per ballast) will be incorporated under the “**Group N**” tab, being N the number of the group they belong to.

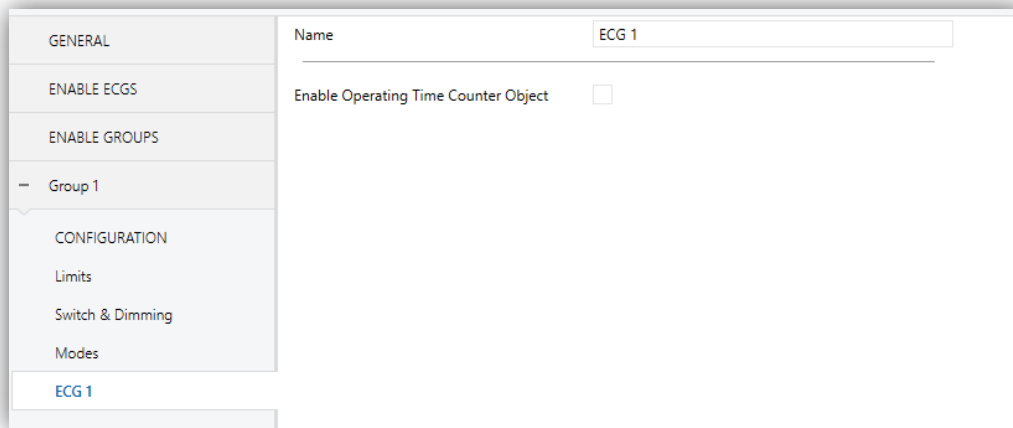

Figure 14. Group N – ECG M

The options they contain are entirely analogous to those describe in section 2.4.1 for ballasts with no group assignment.

## 2.5.3 LIMITS

DALIBOX Interface 64/32 allows configuring two different limit types:

- **Luminosity Limits:** they limit the luminosity ranges controlled by the ballast. These limits are not perceptible by the user, i.e., the dimming range for the KNX bus will still be 0-100%, and the dimming time between both ends (0% to 100%) will be exactly the dimming time parameterised.
- **Ballast Physical Minimum:** minimum luminosity value that the ballast is actually able to produce, as specified by the manufacturer. This

determines the actual luminosity level that will correspond to a dimming percentage of 1%.

**Note:** *physical minimum must be configured as indicated in the ballast or in the datasheet.*

- **Economic Mode:** maximum luminosity level the ballast will be allowed to reach. It determines the actual luminosity level that will correspond to a dimming percentage of 100%.
- **Dimming Limits:** perceptible limits that allow restricting the percentage value range of the control objects. Note that the actual meaning of the values of these objects depends itself on the luminosity limits configured. The effect of these limits over the dimming times is explained in section 2.1.
  - **Minimum Dimming Value:** lower dimming percentage allowed. The load will remain at this level in case of receiving a lower value (only switch-off orders will be handled).
  - **Maximum Dimming Value:** upper dimming percentage allowed. The load will remain at this level in case of receiving a greater value.

The dimming curve takes into account all the above limits.

---

## ETS PARAMETERISATION

---

The '**Limits**' tab provides the following options:

GENERAL	LUMINOSITY LIMITS
ENABLE ECGS	Ballast Physical Minimum <input checked="" type="checkbox"/>
ENABLE GROUPS	Minimum Luminosity Level <input type="text" value="10"/> x 0.1%
Group 1	Economical Mode <input type="checkbox"/>
CONFIGURATION	DIMMING LIMITS
Limits	Minimum Dimming Value <input type="text" value="0"/> %
Switch & Dimming	Maximum Dimming Value <input type="text" value="100"/> %

Figure 15. Limits

- **Luminosity Limits:**

- **Ballast Physical Minimum:** enables or disables the physical minimum for the ballasts of the group.
  - **Minimum Luminosity Level:** the available range is 1 to 100 tenths (0.1% to 10%).
- **Economical Mode:** enables or disables the economic mode.
  - **Maximum Luminosity Level:** the available range is 100 to 1000 tenths (10% to 100%).
- **Dimming Limits:**
  - **Minimum Dimming Value:** the available range is 0% to 100%.
  - **Maximum Dimming Value:** the available range is 0% to 100%.

#### 2.5.4 SWITCH & DIMMING

---

DALIBOX Interface 64/32 lets configuring the general On/Off switch control so that these actions are performed **immediately** or through a **smooth regulation** (according to one of the three configurable dimming times detailed in section 2.1).

Furthermore, it is possible to specify the luminosity level that the group will adopt when a general switch-on order is executed: either a **fixed value** (configurable in parameters) or the **last value** prior to the switch-off (i.e., a memory switch-on). In addition, in case of selecting the latter, it is possible to select whether a **second switch-on order** should set the maximum dimming value.

DALIBOX Interface 64/32 provides two general dimming controls besides the general On/Off control:

- **Relative Dimming:** modifies the dimming level through orders to increment or decrement it by fixed percentages (“1.6%”, “3.1%”, “6.3%”, “12.5%”, “25%”, “50%” or “100%”), which will be added to or subtracted from the current dimming level of the group. A **four-bit object** is provided for the reception of the relative dimming orders.

It is possible to select whether it will be possible to switch off a group through a relative dimming order, in case the target value is lower than the minimum



parameterised. If not enabled, the group will remain at the minimum level parameterised.

- **Absolute dimming:** modifies the dimming level through orders that specify the desired target value, regardless of the current value of the group. A **one-byte object** is provided for the reception of the absolute dimming orders.

For both dimming modes, the dimming time for the 0% to 100% transition may be selected among the three different dimming times already defined. An immediate transition can also be configured, if desired.

**Note:** in case of configuring dimming limits (see section 2.5.3), they will be applied as follows:

- *Transitions between 0% and the minimum dimming value will be instantaneous.*
- *Transitions between the minimum dimming value and the maximum dimming value will take the proportional part of the parameterised dimming time (which must be understood as the time corresponding to the entire transition from 0% to 100%).*

---

## ETS PARAMETERISATION

---

The following parameters are available in the “**Switch & Dimming**” tab:

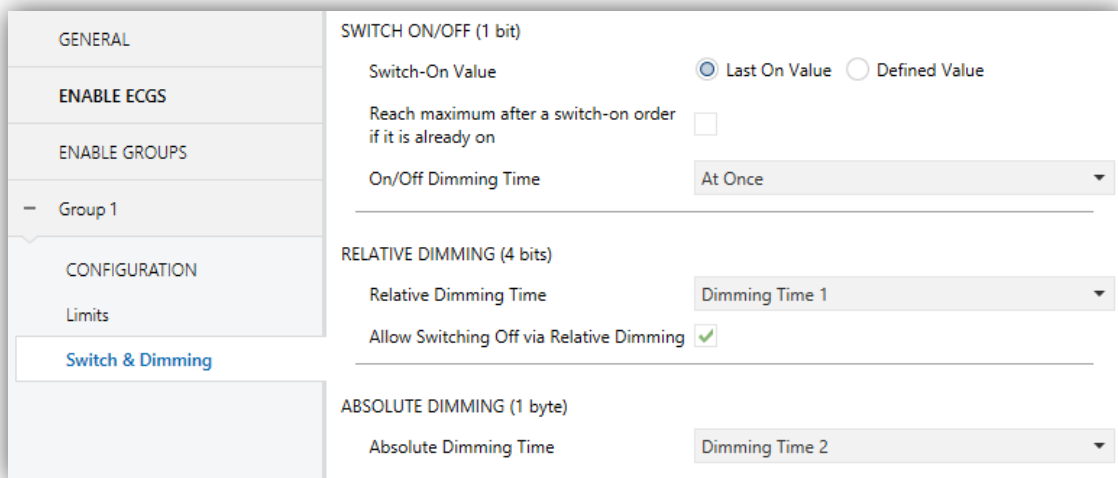

Figure 16. Switch & Dimming

- **Switch On/Off (1 bit):**

- **Switch On Value:** allows selecting the general dimming level that will be adopted by the group when the value “1” is received through “[Group n] On/Off”. It can be “Last On Value” (default option) or “Defined Value”.
  - In case of selecting “Last On Value”:
    - **Reach Maximum after a Switch On Order if it’s Already On:** enables or disables the option to switch to the maximum dimming level through a second switch-on order.
  - In case of selecting “Defined Value”:
    - **Value:** the available range is 0% to 100%.
- **On/Off Dimming Time:** “At Once” (option by default) or “Dimming Time  $n$ ” (with  $n=1,2,3$ ).
- **Relative Dimming (4 bits):** allows setting up the configuration of the relative dimming function and the **four-bit** object “[Group n] Relative Dimming”.
  - **Relative Dimming Time:** “At Once”, “Dimming Time 1”, “Dimming Time 2”, “Dimming Time 3”.
  - **Allow Switching Off via Relative Dimming:** sets whether the group should be switched off in case a decrease order with a dimming value lower than the minimum value parameterised is received.
- **Absolute Dimming (1 byte):** this section allows setting up the configuration of the relative absolute dimming function and the **one-byte** object “[Group n] Absolute Dimming”.
  - **Absolute Dimming Time:** analogous to the above parameter.

### 2.5.5 STATUS OBJECTS

---

DALIBOX Interface 64/32 provides different objects that report the current dimming state of the output group:

- A **one-bit object** (On/Off).
- A **one-byte object**, which indicates the dimming level (in percentage).

## ETS PARAMETERISATION

After enabling this function, the following options will be available in the “Status Objects” tab:

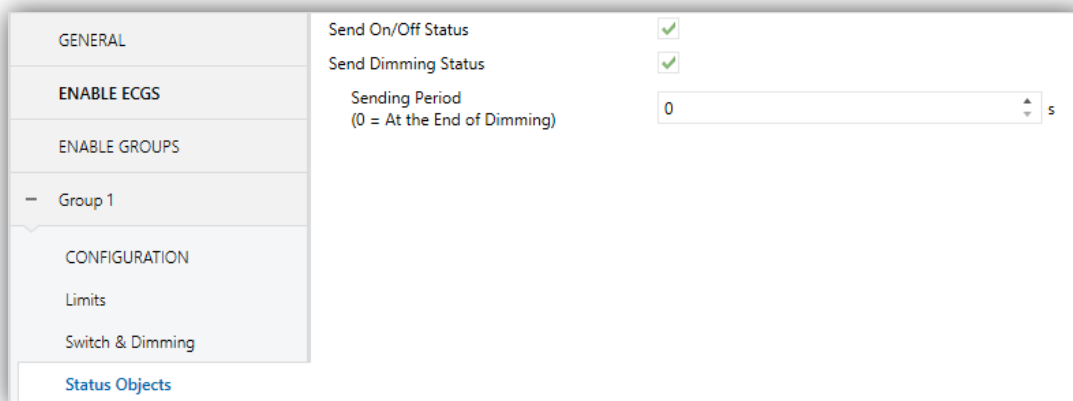

Figure 17. Status Objects

- **Send On/Off Status:** enables a one-bit object (“**[Group n] On/Off (Status)**”) that will be sent whenever the group is switched off (“0”) or on (“1”).
- **Send Dimming Status:** enables a one-byte object (“**[Group n] Dimming Value (Status)**”) that will be sent with the current dimming value of the group (between 0% and 100%) whenever it changes. Enabling this parameter brings up an addition one:
  - **Sending Period:** defines the sending cycle time (1 to 255 seconds) of the status object during a dimming process. If it is set to “0”, the dimming status will be sent only at the end of the dimming process.

### 2.5.6 CUSTOM ON/OFF

This function offers one additional On/Off control for each group, and therefore another new communication object to switch the ballasts on and off.

This additional control can be customised with specific dimming levels for the “On” and “Off” states, and may also be configured to perform an immediate or soft dimming.

## ETS PARAMETERISATION

Once the function has been enabled, the “[Group n] Custom On/Off” one-bit object and a specific parameter tab will show in ETS:

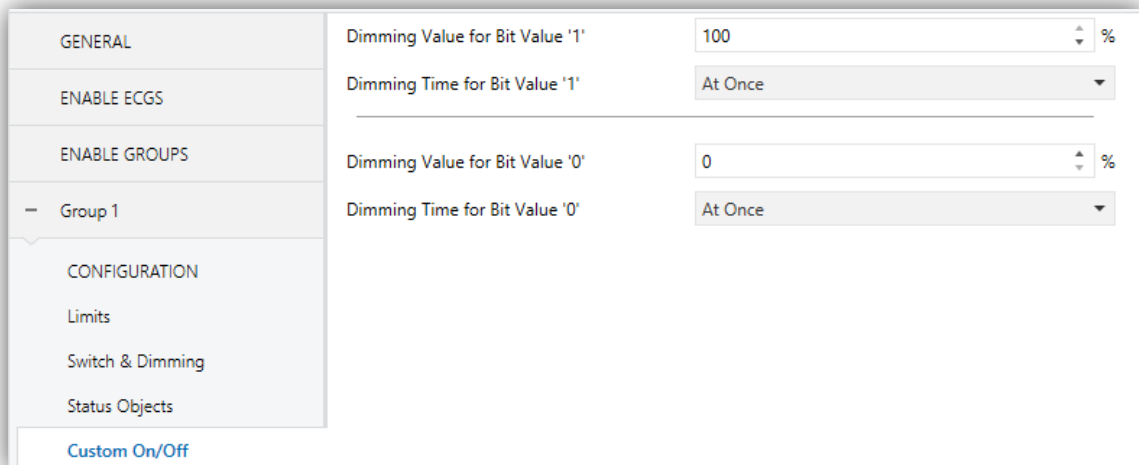

Figure 18. Custom On/Off

This new screen allows setting up the specific behaviour when a “1” or a “0” are received through the aforementioned object:

- **Dimming Value for Bit Value ‘1’:** sets a specific dimming percentage (0% to 100%) to be applied to the group when a “1” is received.
- **Dimming Time for Bit Value ‘1’:** “At Once”, “Dimming Time 1”, “Dimming Time 2”, “Dimming Time 3”..
- **Dimming Value for Bit Value ‘0’** and **Dimming Time for Bit Value ‘0’:** analogous to the above two parameters, but referred to the arrival of the value “0” from the bus.

### 2.5.7 TIMERS

This function allows configuring a **simple timer** and a **flashing sequence** in the output group, being it possible to enable or disable both functions independently.

- The **simple timer** function consists in a switch-on of the group (with an optional delay) on the reception of the corresponding trigger object, and a later switch-off, either automatic (after a certain period) or triggered through the corresponding bus object, also with an optional delay in this case.

- On the other hand, the **flashing** function consists in switching the group on and off a certain number of times or indefinitely, according to the parameters, once the corresponding object is received.

---

## ETS PARAMETERISATION

---

After enabling this option, the following parameters will show in ETS:

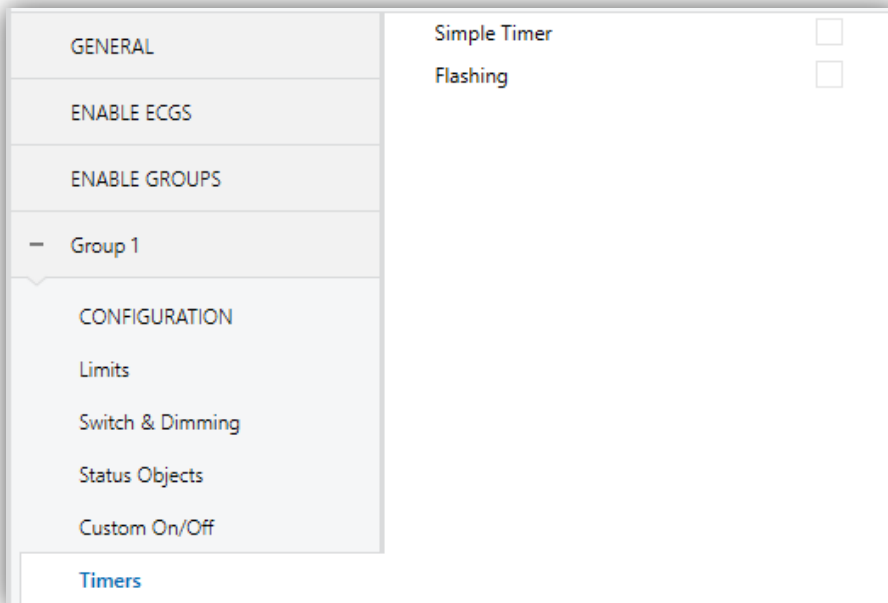

Figure 19. Timers

**Simple Timer** and **Flashing** are disabled by default. Once enabled, the “[Group n] Simple Timer” and “[Group n] Flashing” one-bit objects are added to the project topology. An additional parameter tab for each option shows up too, as described next.

### 2.5.7.1 SIMPLE TIMER

---

The simple timer function requires configuring the following options:

- **On Delay:** delay between the reception of the simple timer trigger order and the actual switch-on of the group.
- **Off Delay:** delay between the reception of the simple timer stop order and the actual switch-off of the group.
- **On Duration:** time the group must remain on before being automatically switched off (unless the stop order is received from the bus, which will switch the group off immediately).

- **Action in Case of Retriggering:** action to be performed in case the simple value trigger order is received several times.
  - **Nothing:** the current time count will not be restarted.
  - **Restart:** the time count of the On Duration will be restarted from zero.
  - **Multiply:** the time count of the On Duration will become 'n' times the configured time, being 'n' the number of times the value "1" is received (up to 5 times).
- **On Value:** dimming level to be applied to the group during the "on" stage.
- **Dimming Time:** desired regulation type for the transitions.

**Note:** the simple timer function will be interrupted whenever any other dimming action is commanded, no matter if it falls within the On Duration or during the On/Off delays.

## ETS PARAMETERISATION

GENERAL	On Delay (0 = No Delay)	0
ENABLE ECSS		<input checked="" type="radio"/> s <input type="radio"/> min
ENABLE GROUPS	Off Delay (0 = No Delay)	0
Group 1		<input checked="" type="radio"/> s <input type="radio"/> min
CONFIGURATION	On Duration (0 = Endless)	0
Limits		<input checked="" type="radio"/> s <input type="radio"/> min
Switch & Dimming	Action in Case of Retriggering	Nothing
Status Objects	On Value	100 %
Custom On/Off	Dimming Time	At Once
Timers		

Figure 20. Simple Timer

Once the simple timer function has been enabled, the “[Group n] Simple Timer” one-bit object becomes enabled too, making it possible to trigger a switch-on by sending it the value “1” or a switch-off by sending it the value “0”. Both actions can be delayed according to the following parameters:

- **On Delay:** sets a delay after the reception of value “1” through object “[Group n] Simple Timer”. 0 to 255 seconds or minutes.

- **Off Delay:** sets a delay after the reception of value “0” through object “[Group n] Simple Timer”. 0 to 255 seconds or minutes.
- **On Duration:** sets the time the group will remain on, in the range 0 to 255 seconds or minutes. The value “0” (default option) will disable the automatic switch-off, thus making the group remain on.
- **Action in Case of Retriggering:** sets the action to be performed in case the value “1” is received several times.
  - “Nothing”.
  - “Restart”.
  - “Multiply”.
- **On Value:** sets the specific dimming percentage (0% to 100%) to be applied to the group during the “on” stage.
- **Dimming Time:** “At Once”, “Dimming Time 1”, “Dimming Time 2”, “Dimming Time 3”.

**Example:**

- On delay: 2 s.
- Off delay: 2 s.
- On duration: 4 s.
- On value: 100%.
- Dimming time: immediate.

Assuming that the “1” labels correspond to the arrivals of the value “1” through the “[Group n] Simple Timer” and that the “0” labels correspond to the arrival of the value “0”, the expected behaviour will be:

Action in case of retriggering: nothing

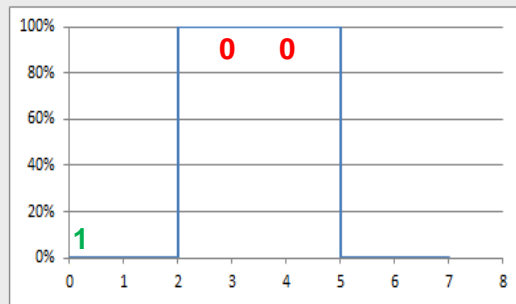
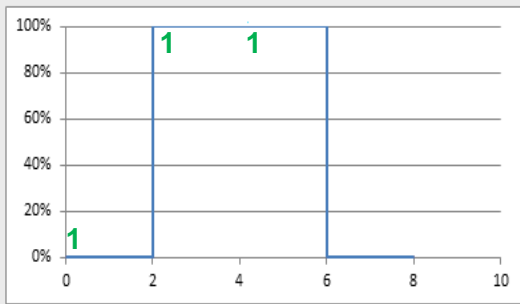

Action in case of retriggering: restart

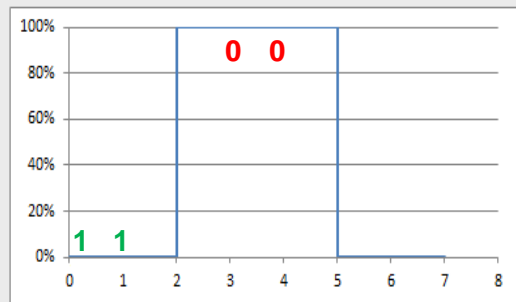
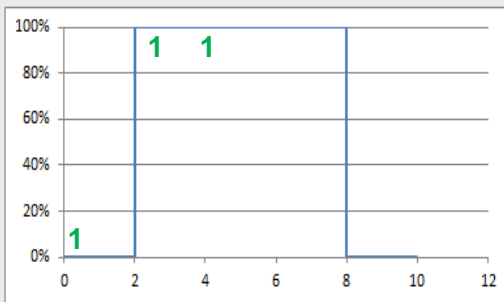

Action in case of retriggering = multiply

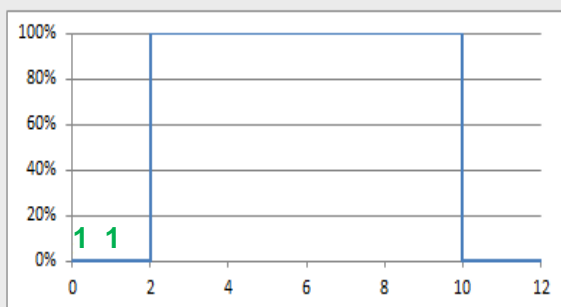
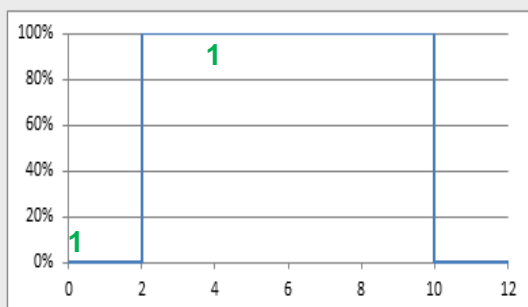



### 2.5.7.2 FLASHING

The flashing function requires configuring the following options:

- **On Duration:** length of each “On” stage during the sequence.
- **Off Duration:** length of each “Off” stage during the sequence.
- **Repetitions:** number of iterations of the sequence.
- **On Value:** dimming level to be applied to the group during the “On” stages.
- **Final Value:** dimming level to be applied to the group after the last repetition or after the reception.

### PARAMETRIZACIÓN ETS

Once the flashing function has been enabled, the “[Group n] Flashing” one-bit object will turn visible in order to let triggering an On-Off-On... sequence by sending it the value “1”, as well as interrupting it by sending it the value “0”. The options for this function are the following:

GENERAL	On Duration	1
ENABLE ECGS		<input checked="" type="radio"/> s <input type="radio"/> min
ENABLE GROUPS	Off Duration	1
Group 1		<input checked="" type="radio"/> s <input type="radio"/> min
CONFIGURATION	Repetitions (0 = Endless)	0
Limits	On Value	100 %
Switch & Dimming	Final Value	0 %
Timers		
Simple Timer		
Flashing		

Figure 21. Flashing

- **On Duration:** sets the length of each “On” stage, in the range 1 to 255 seconds or minutes.
- **Off Duration:** sets the length of each “Off” stage, in the range 1 to 255 seconds or minutes.

- **Repetitions:** sets the number of iterations of the sequence, between 0 and 255. A value of “0” (default option) causes an endless repetition, until an order to interrupt the sequence is received.
- **On Value:** sets a specific dimming percentage (0% to 100%) to be applied to the group during the “On” stages.
- **Final Value:** sets a specific dimming value (0% to 100%) to be applied to the group after the last repetition or after the reception of one “0” through the “[Group n] Flashing” communication object.

## 2.5.8 LOCK

Enabling the lock function will bring a **one-bit** object which will allow locking and unlocking the group. Group locking causes that any bus orders addressing to that group are ignored.

Receiving a lock order while running a sequence, a flashing sequence or a timed action **will stop the execution of that action.**

### ETS PARAMETERISATION

Once this function has been enabled, the following options will show in ETS:

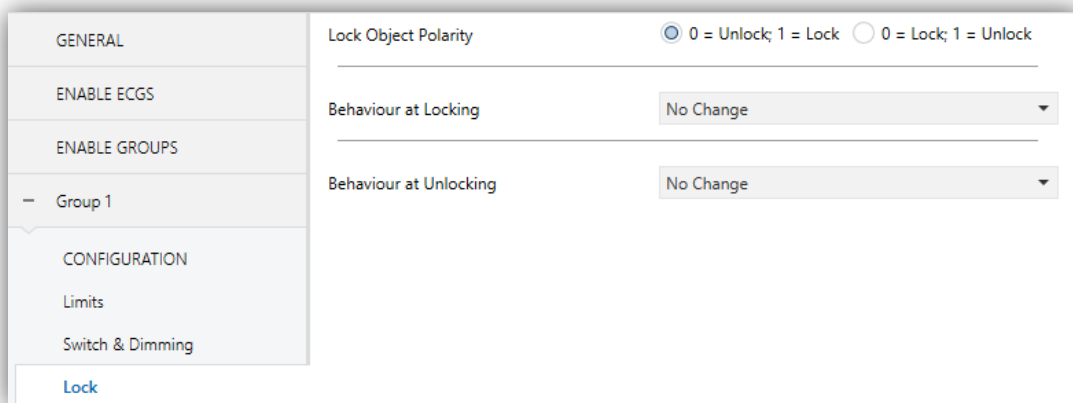

Figure 22. Lock

- **Lock Object Polarity:** sets which value will be interpreted as a lock order and which one as an unlock order: “0 = Unlock; 1 = Lock” (default) or “0 = Lock; 1 = Unlock”.

- **Behaviour at Locking:** sets the action to be performed when a lock order is received: “No Change” (default option), “Off” (the group will be switch off), “On” (the group will be switched on) or “Defined Value” (a value between 0% and 100% will be parameterisable).
- **Behaviour at Unlocking:** sets the action to be performed when an unlock order is received. The options are analogous to those for locking, but will also comprise the following one: “Previous State” (to recover the status previous to the lock order).

## 2.5.9 CUSTOM INITIALISATION

This function lets customising the state of the group after the start-up of the device.

Opting for the **default initial configuration** implies the following:

- After an ETS download, the ballasts of the group will remain off.
- After recovering from a KNX bus power failure, the ballasts of the group will recover their state previous to the power failure.

On the other hand, opting for a **custom initial configuration** allows parameterising the desired state after the bus power is restored or after a download.

**Note:** *KNX bus failures do not switch off the ballasts, unless their own power supply is interrupted.*

### ETS PARAMETERISATION

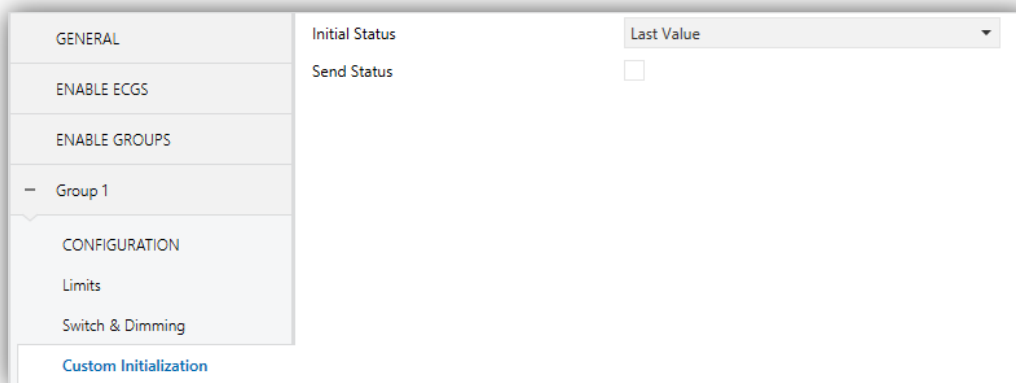

Figure 23. Custom initialisation

Once the option to customise the initial configuration has been enabled (otherwise, the default configuration will be applied) the following parameters will show in ETS:

- **Initial Status:** sets the desired initial state of the group:
  - “Last” (default value): when the KNX bus power is restored, the group will recover the dimming state previous to the bus failure. Note that this option has no effect after a download (the group will remain off).
  - “Off”: the group will always start switched off.
  - “Defined Value”: the group will start at a specific dimming level (between 0% and 100%), configured in “**Value**”.
  
- **Send Status:** if enabled, the status objects will be sent to the bus at the start-up to inform about the initial state of the group. This requires that the status objects have been enabled (see section 2.5.5).
  - **Delay:** sets a delay (in seconds) before performing this sending.

## 2.5.10 MODES

---

DALIBOX Interface 64/32 implements two special operation options named as **Burn-in mode** and **Auto-Off mode**, each of which is explained in detail next.

### 2.5.10.1 AUTO OFF MODE

---

The Auto Off mode allows an automatic switch-off of the group if it is found to be steady (i.e., without receiving further dimming orders) under a certain dimming value – or threshold– for at least a certain amount of time (configurable).

This function will not take place while any of the following is active:

- Power supply error.
- Short-circuit error.
- Test On mode.
- Lock.
- Burn-in mode.
- Timers.

## ETS PARAMETERISATION

Once the Modes option has been enabled, the following parameters regarding the Auto Off function will show in ETS:

GENERAL	Auto Off	<input checked="" type="checkbox"/>
ENABLE ECGS	Threshold Value	10 %
ENABLE GROUPS	Threshold Time	10
Group 1		<input checked="" type="radio"/> s <input type="radio"/> min
CONFIGURATION	Burn-in	<input checked="" type="checkbox"/>
Limits	Burn-in Time	100 h
Switch & Dimming	Start Burn-in After Programming	<input type="checkbox"/>
Modes		

Figure 24. Modes

- **Auto Off:** allows enabling the Auto Off function.
  - **Threshold Value:** dimming value (between 1% and 100%, with 10% as the default value) beneath which the Auto Off will be triggered in case the group remains steady at that value for more than the threshold time.
  - **Threshold Time:** time count before triggering the Auto Off mode, between 1-50 seconds or minutes (10 seconds by default).

### 2.5.10.2 BURN-IN MODE

The Burn-in mode is intended for certain lamp types (such as steam lamps) which need to remain on for a certain time period **before performing any light dimming**. To that end, before the ballasts of the group have been (steadily) switched on for at least the configured time, it will only be possible to **switch the loads off or to regulate them to 100%**.

In case of having configured any **limits** (either luminosity limits or dimming limits; see section 2.5.3), they will not be considered while the Burn-in mode is in operation, i.e., the loads will be actually switched on entirely. However, they will be applied once the Burn-in mode is over, which will may be perceived as a slight change in the light level.

This functionality entails certain effects over other functions (while the Burn-in mode remains active, any dimming order greater than 0% will be executed as an immediate

regulation to 100%, or to 0% in other case):

- Relative and absolute dimming.
- Simple timers and flashing.
- Lock/unlock actions.
- Initialisation.
- Installation test (see section 2.8).
- DALI bus failure (see section 2.5.1).

An object is provided to force the activation or deactivation of the Burn-in mode at any time.

## ETS PARAMETERISATION

Once the Modes option has been enabled, the following parameters will show in ETS:

GENERAL	Auto Off	<input checked="" type="checkbox"/>
ENABLE ECGS	Threshold Value	10 %
ENABLE GROUPS	Threshold Time	10 min
Group 1		
CONFIGURATION	Burn-in	<input checked="" type="checkbox"/>
Limits	Burn-in Time	100 h
Switch & Dimming	Start Burn-in After Programming	<input type="checkbox"/>
Modes		

Figure 25. Modes

- **Burn-in:** allows enabling the Burn-in function. In such case, two new objects become available:
  - “[Group n] Burn-in Mode (Status)”, which will be sent when the group enters (value “1”) or leaves (value “0”) the Burn-in mode.
  - “[Group n] Burn-in Mode”, which allows forcing the activation (value “1”) or deactivation (value “0”) of the Burn-in mode at any time, as well as restarting the time count in case it is already active.

The following parameters will also be available:

- **Burn-in Time:** sets the time the Burn-in mode should last, between 1 and 255 hours (100 h by default).
- **Start Burn-in After Programming:** sets whether the start-up actions configured (see section 2.5.9) should be applied the Burn-in restrictions or not.

**Note:** this option will have no effect *if the **Overwrite group assignment when downloading** parameter has not been enabled (see section 2.2).*

## 2.6 SCENES

### 2.6.1 CONFIGURATION

This feature allows defining different scenes (i.e., specific ambiances or dimming sequences), which can be activated by sending the corresponding trigger values to a **one-byte object**.

DALIBOX Interface 64/32 offers **up to 32** configurable scenes which can be assigned to the different enabled groups.

#### ETS PARAMETERISATION

Once this function has been enabled, the following object will show in ETS:

- **“Scene Control”** (one byte): will execute or save the scene whose number is received through the object.

The **“Scenes”** tab in ETS, on its side, contains a sub-tab named **“Configuration”**, which shows the following parameters:

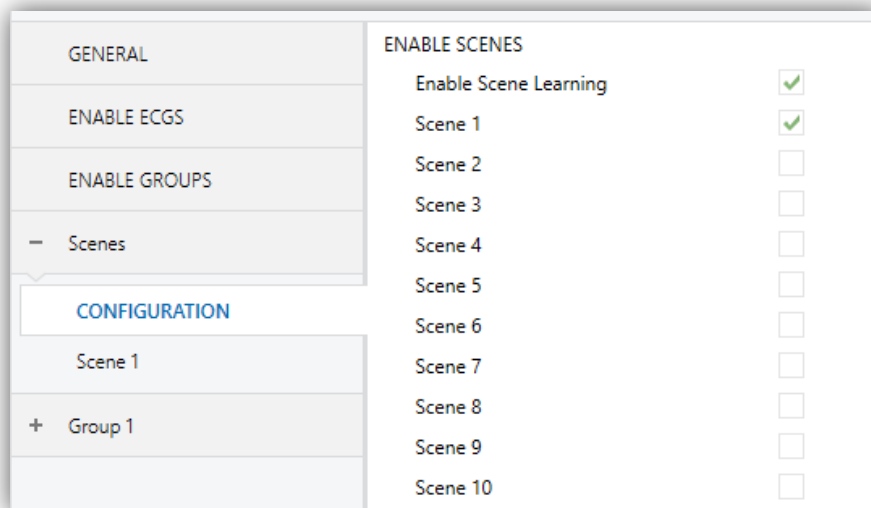

Figure 26. Configuration

- **Scene learning**: enables the possibility of over-writing a certain scene when the appropriate value is received from the bus through the aforementioned object.
- **Scene N**: enables scene number N (1 to 32).



Each scene activated from this screen will have a specific tab associated, labelled as “**Scene ‘n’**”, as detailed next.

## 2.6.2 SCENE N

Each of up to 32 scenes must be assigned a certain identifier, i.e., their scene number with regards to the KNX system. When this value is received through the scenes object, the scene will be executed (or saved, in case the value is received incremented by 128, according to the KNX standard).

The specific action to be performed by each group on the execution of the scene can be selectively configured.

### ETS PARAMETERISATION

Navigation	Parameter	Value
GENERAL	Scene Number	1
ENABLE ECGS		
ENABLE GROUPS		
Scenes		
CONFIGURATION		
Scene 1		
+ Group 1		
+ Group 2		
+ Group 3		
+ Group 4		
	AVAILABLE GROUPS	
	Associate Group 1 with this Scene	<input checked="" type="checkbox"/>
	Value	100 %
	Associate Group 2 with this Scene	<input checked="" type="checkbox"/>
	Value	100 %
	Associate Group 3 with this Scene	<input type="checkbox"/>
	Associate Group 4 with this Scene	<input type="checkbox"/>

Figure 27. Scene N

- **Scene Number:** sets the scene identifying number (from 1 to 64) whose reception through the “**Scene Control**” object will make the device execute or save the scene depending on the case.
- **Associate Group M with This Scene:** allows associating the scene to the different available groups and configuring the target dimming level (**Value**, between 0% and 100%) for each one, which can be different. It is important to take into account that there can be different scenes associated to the same group.

## 2.7 SEQUENCES

### 2.7.1 CONFIGURATION

This feature allows defining **up to 16** configurable dimming sequences, which can perform actions on different groups. Sequences can be executed simultaneously, as starting a new one does not stop other sequences in execution.

#### ETS PARAMETERISATION

Once this function has been enabled, the following objects will show in ETS:

- **“Sequence Control”** (one byte): will trigger the sequence whose number is received through the object, as detailed next:

Sequence Number	Stop	Start
1	0	128
2	1	129
...	...	...
64	63	191

Table 3. Sequence Control

- **“Sequence Launcher”** (one byte): similar to the scenes object (see section 2.6), but without the “save” functionality:

Sequence Number	Start
1	0
2	1
...	...
64	63

Table 4. Sequence Launcher

- **“Stop Sequences”** (one bit): interrupts all current sequences when it receives either a “1” or a “0”.

The **“Configuration”** tab in ETS contains the following parameters:

- **Sequence N**: enables sequence number N.

A specific tab will be incorporated for each sequence being enabled.

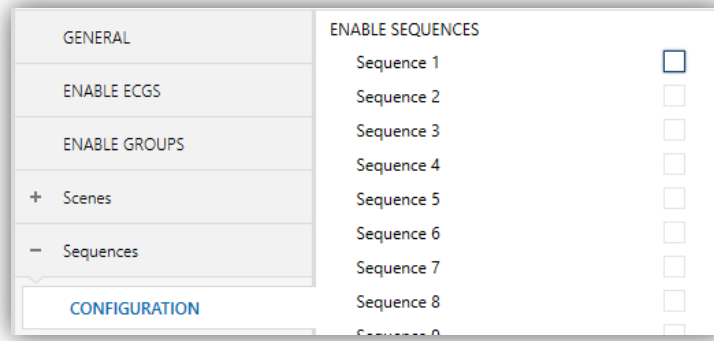

Figure 28. Configuration

## 2.7.2 SEQUENCE N

Each sequence can consist of up to **five actions** executed sequentially. For each of the actions, it is possible to set the group over which the action will be performed, as well as the target dimming value, the dimming type (at once or smooth) and the total length of the action prior to trigger the next one.

### ETS PARAMETERISATION

The “**Sequence N**” tab contains the following parameters:

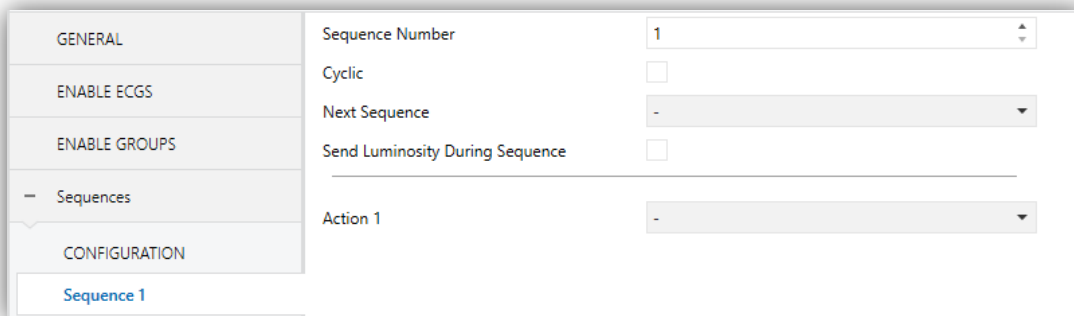

Figure 29. Sequence N

- **Sequence Number:** sets the sequence identifying number (from 1 to 64) whose reception through the aforementioned communication objects will make the device trigger the sequence.
- **Cyclic:** sets whether the sequence should start over or not after the execution of the last action.
- **Next Sequence:** in case the sequence is not **cyclic**, this parameter allows the execution of another sequence after the last action of the current one.

The options are “No Sequence” and “Sequence ‘n’”, being ‘n’ a value between 1 and 64.

Each sequence allows enabling up to **five actions**:

**Figure 30.** Sequence (example)

- **Action M:** enables action number M and associates it to a particular group.

**Note:** if the selected group has not been enabled, the action will have no effect.

- **Value:** sets the target dimming level between 0% and 100%.

- **Dimming Time:** “At Once”, “Dimming Time 1”, “Dimming Time 2”, “Dimming Time 3”, “Time to Next Action” (in this case, the dimming time –i.e., the total time for a transition from 0% to 100– will match the action time, which is configured through the next parameter).
- **Time to Next Action:** defines the length of the action, i.e., the time it will take until the next action begins, between 0 to 255 seconds or minutes.
- **Send Luminosity During Sequence:** sets whether the “[Group X] Dimming Value (Status)” object should be sent during the sequence.

An example of custom sequence configuration is shown in Figure 30.

**Important:** *in order to avoid action overlapping between groups or within the same group, please configure the **Dimming Time** and the **Time to Next Action** with caution.*

## 2.8 DISPLAY

---

### 2.8.1 MAIN MENU

---

DALIBOX Interface 64/32 incorporates a **128x64 pixel display** together with **six additional buttons** to browse through the options it shows.

During normal device operation of the device, the screen remains off to save power. Pressing on a button (arrows, OK or ESC) will activate it back and show the main menu. After **a minute** without further interaction, it will turn off again.

This **main menu** (i.e., the upper level) includes a list with the following options:

1. Installation
2. Reset All ECGs
3. Manual Control
4. Scene Control
5. Burn-in Control
6. Application Version

It is possible to browse through them by pressing on ▼ and ▲. To enter any of the submenus, please press OK. To return to the previous menu, please press ESC.

**Note:** *if a power supply failure or a short-circuit error takes place, the display will switch back to the upper menu in case any of the submenus has been opened. A “**Bus Error**” message will be shown if trying to open any submenus until the error is over.*

### 2.8.2 INSTALLATION

---

This submenu allows performing the following actions, which may be useful during the installation of the DALI system or during later maintenance:

- Testing the ECGs present in the DALI bus.
- Identifying or modifying the addresses of the ECGs detected.
- Identifying or modifying the group assignment of each ECG.
- Checking any errors on the ECGs and resetting the presence error.
- Checking the operating hours of the ECGs and resetting the time count.

All the above actions can be performed over any ECGs present in the line, even if they have not been enabled in parameters before (see section 2.2).

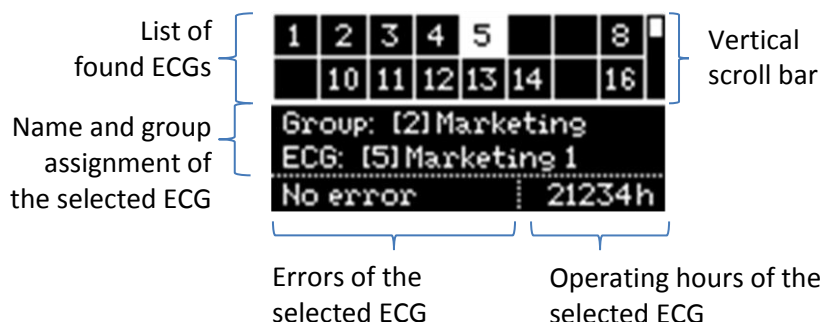

Figure 31. Installation Submenu

**Note:** after leaving the Installation menu, the previous dimming values are resumed, in case they have been modified.

### 2.8.2.1 SELECTION AND ECG TESTING

The cells in the upper table represent the detected ballasts. Empty cells correspond to addresses that have not been assigned to any of the ballasts. To step through the different cells, please make use of the arrow buttons. Note that only two rows are shown simultaneously – to reach the other rows please make use of the up and down arrow buttons.

The currently highlighted box will **blink** every second, and so will do the corresponding ballast thus making it possible to identify which ballast has been assigned each address.

By pressing on **OK**, the selected cell will become surrounded by a dotted line and the ballast will interrupt the on-off sequence. This allows entering into the group assignment section.

### 2.8.2.2 GROUP ASSIGNMENT

After entering the group assignment section, the ◀ and ▶ buttons allow browsing through the available groups. The “**No Group**” option is available at the end of the list. To set the assignment please press on **OK**. A pop-up message (“**Change Group?**”) will ask for confirmation, which consists in pressing on **OK** again.

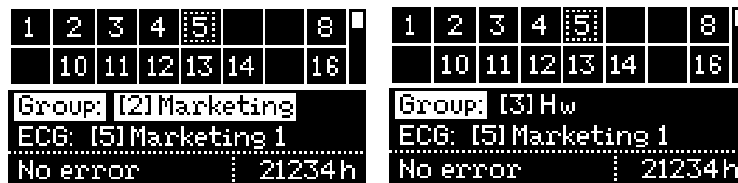

Figure 32. Group Assignment

Figure 32 shows how the display looks like when ballast with address 5 (initially belonging to group number 2) is re-assigned group number 3.

**Important:** if a ballast is assigned an individual group (17-32) previously assigned to another ballast, the latter will change to “No group”.

To enter the ECG address assignment section, please press ▼. To switch back to the upper table, please press ESC or ▲.

### 2.8.2.3 ADDRESS ASSIGNMENT

Analogously as in section 2.8.2.2, it is possible to modify the address of the selected ballast. After entering this section, ◀ and ▶ will permit browsing through the available addresses (both unused addresses and addresses already in use).

Free addresses and addresses automatically assigned by DALIBOX Interface 64/32 (which therefore have not been given a name in ETS; see section 2.2) will simply show as a number in square brackets, with no name.



Figure 33. ECG Address

To confirm the assignment please press on **OK**. It is important to bear in mind that:

- When assigning an address that was free, the current cell in the table will become empty while the cell corresponding to the new address will no longer be empty.
- When assigning an address that was already assigned to another ballast, DALIBOX Interface 64/32 will automatically assign the latter a new address. In case the sixty four addresses are already in use, **the assignment will not be possible**: after pressing on OK, the current address will remain assigned.



In such case, in order to perform an address swap, it is advisable to disconnect a ballast whose address has not been configured yet (thus, a ballast whose address has been assigned automatically), perform the intended assignment and re-connect the ballast (which will be automatically assigned by DALIBOX Interface 64/32 the only address available).

To enter the ballast errors section, please press ▼.

#### 2.8.2.4 BALLAST ERRORS

This box will reflect the errors of the selected ballast (see section 2.1.1):

- If no errors are present, the box will show **“No error”**.
- In case of a presence error, an ECG error or a lamp error, the box will respectively show **“Err: Presence”**, **“Err: ECG Failure”** and **“Err: Lamp Failure”**. In case the latter two errors take place simultaneously, it will show **“Err: ECG & Lamp”**.
- Power supply errors and short-circuit errors will be indicated by DALIBOX Interface 64/32, respectively, through the messages **“Bus Error: Power Supply”** and **“Bus Error: Shor Circuit”** directly when trying to enter the Installation submenu.

1	2	3	4	5			8	
	10	11	12	13	14		16	
Group: [2] Marketing								
ECG: [5] Marketing 1								
Error: presence: 21234 h								

Figure 34. ECG Errors

**Ballasts under the ECG presence error** can be removed from the upper table in case they are not necessary anymore and therefore have been removed from the DALI bus. To that end, once in the ballast errors section of a ballast in such situation, please press on **OK**. Pressing a second time on **OK** will confirm the **“Delete ECG?”** dialogue, and therefore the ballast will be removed. To cancel the action, please press any other button.



Figure 35. Deleting an ECG

To enter the operating time section, please press ▼.

### 2.8.2.5 OPERATING TIME

This box shows the total operation hours of the selected ballast (see section 2.4.1 and section 2.5.2) even if the associated object has not been enabled in parameters. Note that this count is performed by DALIBOX Interface 64/32 according to the hours it maintains the ballast dimming level over 0%.



Figure 36. Operating time

Once in this section, to reset this time count to zero (e.g., when replacing the lamp in the ballast) please press **OK**. After the “Reset Time?” message shows, please press **OK** again to confirm the action or any other button to cancel.

### 2.8.3 RESET ALL ECGS

This submenu allows resetting all the ballasts connected to the bus to their defaults, thus removing their address assignments, after which DALIBOX Interface 64/32 will proceed with the **automatic ECG detection and address assignment process after one minute**. This delay allows the integrator disconnect from the DALI bus any ballasts that may not need to be assigned a new address.

This process **does not alter the group assignments**.

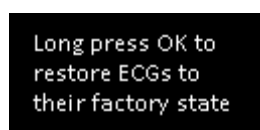

Figure 37. Reset All ECGs Submenu

After a long press on **OK**, the “**Restore ECGs?**” message will show. To confirm, please short-press **OK** and the process will start. Otherwise, please press on any other button.

### 2.8.4 MANUAL CONTROL

This submenu allows controlling the dimming level of the different groups manually. The **actions that can be performed** are: switch-on, switch-off, upward dimming and downward dimming.

After entering this submenu, a group selection table will show on the upper section of the display. Empty cells correspond to group numbers (between 1 and 32) not being used. Please make use of ◀, ▶, ▼ and ▲ to browse through all of them.

The lower section of the display will show the number and (if set in parameters) the name of the selected group.

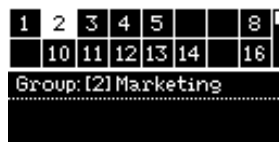

Figure 38. Manual Control

To begin controlling the group, please press **OK**. The lower section will then show the corresponding **instructions**:

- Encendido: ▶
- Apagado: ◀
- Regulación ascendente: ▲
- Regulación descendente: ▼



Figure 39. Manual Control - Instructions

## 2.8.5 SCENE CONTROL

This submenu allows manually controlling the scene **execution** and **saving**. Scene saving will only be possible in case it has been enabled in parameters (section 2.6).

After entering this submenu, a table with the **16 available scenes** is shown. Please make use of ◀, ▶, ▼ and ▲ to browse through them. Note that empty cells correspond to scenes that have not been enabled.

The lower section shows the instructions on how to run or save the scene:

- **To run the selected scene**, please short-press on **OK**.
- **To save the selected scene**, please long-press on **OK**.

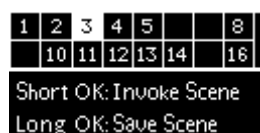

Figure 40. Scene Control

After running or saving a scene, a confirmation text will be shown (respectively, “**Scene N invoked**” or “**Scene N saved**”).

## 2.8.6 BURN-IN CONTROL

This submenu allows checking the **burn-in mode status** (see section 2.5.10.2) of each group, as well as **activating** or **deactivating** this mode. This may be a requirement of some lamps prior to testing them.

After entering this submenu, the upper section of the display will show a group selection table analogous to that in the manual control submenu (see section 2.8.4). On the other side, the lower section will show the number, the name and the burn-in mode status of the selected group, together with the instructions to activate or deactivate this mode (**long press on OK** to activate it or, if already active, **long press on OK** to deactivate it).



Figure 41. Burn-in Control

**Important:** *in case the burn-in mode of a particular group has not been enabled in parameters, it will still show up in the group selection table, however the message “Burn-in state: not available” will be shown if trying to activate it.*

## 2.8.7 APPLICATION VERSION

---

The Application Version submenu indicates, through the same text line of the main menu, the currently downloaded version of the device application program.



Figure 42. Application Version

## ANNEX I. COMMUNICATION OBJECTS

- “Functional range” shows the values that, with independence of any other values permitted by the bus according to the object size, may be of any use or have a particular meaning because of the specifications or restrictions from both the KNX standard or the application programme itself.

Number	Size	I/O	Flags	Data type (DPT)	Functional Range	Name	Function
1	2 Bytes	I	C - - W -	DPT_TimePeriodSec	0 - 65535	Dimming Time 1	Time in Seconds
2	2 Bytes	I	C - - W -	DPT_TimePeriodSec	0 - 65535	Dimming Time 2	Time in Seconds
3	2 Bytes	I	C - - W -	DPT_TimePeriodSec	0 - 65535	Dimming Time 3	Time in Seconds
4	1 Byte	I	C - - W -	DPT_SceneControl	0-63; 128-191	Scene Control	Scene Number + Activate/Learn
5	1 Byte	I	C - - W -		0-63; 128-191	Sequence Control	Sequence Number + Start/Stop
6	1 Byte	I	C - - W -	DPT_SceneControl	0-63; 128-191	Sequence Launcher	Start Sequence Number
7	1 Bit	I	C - - W -	DPT_Trigger	0/1	Stop Sequences	Stop All Sequences
8	1 Bit	O	CTR - -	DPT_Alarm	0/1	Error: DALI Power Supply	0 = No Error; 1 = DALI Power Supply Failure
9	1 Bit	O	CTR - -	DPT_Alarm	0/1	Error: Short Circuit	0 = No Error; 1 = Short Circuit
10	1 Bit	O	CTR - -	DPT_Alarm	0/1	Error: ECG Presence	0 = No Error; 1 = ECG Presence Failure
11	2 Bytes	I	CT - W -	DPST-237-600	-	ECG and Group Diagnostic	ECG and Group Diagnostic
12	1 Byte	O	CTR - -	DPST-238-600	-	ECG Diagnostics	ECG Diagnostics
13	1 Bit	O	CTR - -	DPT_Switch	0/1	Standby State	0 = Standby Off; 1 = Standby On
	1 Bit	O	CTR - -	DPT_Switch	0/1	Standby State	0 = Standby On; 1 = Standby Off
14,25, 36, 47, 58, 69, 80, 91, 102, 113, 124, 135, 146, 157, 168, 179, 190, 201, 212, 223, 234, 245, 256, 267, 278, 289, 300, 311, 322, 333, 344, 355	1 Bit	I	C - - W -	DPT_Switch	0/1	[Group n] On/Off	0 = Off; 1 = On
15, 26, 36, 48, 59, 70, 81, 92, 103, 114, 125, 136, 147, 158, 169, 180, 191, 202, 213, 224, 235, 246, 257, 268, 279, 290, 301, 312, 323, 334, 345, 356	4 Bit	I	C - - W -	DPT_Control_Dimming	0x0 (Stop) 0x1 (Dec. by 100%) 0x2 (Dec. by 50%) 0x3 (Dec. by 25%) 0x4 (Dec. by 12%) 0x5 (Dec. by 6%) 0x6 (Dec. by 3%) 0x7 (Dec. by 1%) 0x8 (Stop)	[Group n] Relative Dimming	4 bits Dimmer Control

					0x9 (Inc. by 100%) 0xA (Inc. by 50%) 0xB (Inc. by 25%) 0xC (Inc. by 12%) 0xD (Inc. by 6%) 0xE (Inc. by 3%) 0xF (Inc. by 1%)		
16, 27, 38, 49, 60, 71, 82, 93, 104, 115, 126, 137, 148, 159, 170, 181, 192, 203, 214, 225, 236, 247, 258, 269, 280, 291, 302, 313, 324, 335, 346, 357	1 Byte	I	<b>C - - W -</b>	DPT_Scaling	0% - 100%	[Group n] Absolute Dimming	1 byte Dimmer Control
17, 28, 39, 50, 61, 72, 83, 94, 105, 116, 127, 138, 149, 160, 171, 182, 193, 204, 215, 226, 237, 248, 259, 270, 281, 292, 303, 314, 325, 336, 347, 358	1 Byte	O	<b>CTR - -</b>	DPT_Scaling	0% - 100%	[Group n] Dimming Value (Status)	0 - 100%
18, 29, 40, 51, 62, 73, 84, 95, 106, 117, 128, 139, 150, 161, 172, 183, 194, 205, 216, 227, 238, 249, 260, 271, 282, 293, 304, 315, 326, 337, 348, 359	1 Bit	O	<b>CTR - -</b>	DPT_Switch	0/1	[Group n] On/Off (Status)	0 = Off; 1 = On
19, 30, 41, 52, 63, 74, 85, 96, 107, 118, 129, 140, 151, 162, 173, 184, 195, 206, 217, 228, 239, 250, 261, 272, 283, 294, 305, 316, 327, 338, 349, 360	1 Bit	I	<b>C - - W -</b>	DPT_Switch	0/1	[Group n] Custom On/Off	0 = Off; 1 = On
20, 31, 42, 53, 64, 75, 86, 97, 108, 119, 130, 141, 152, 163, 174, 185, 196, 207, 218, 229, 240, 251, 262, 273, 284, 295, 306, 317, 328, 339, 350, 361	1 Bit	I	<b>C - - W -</b>	DPT_Start	0/1	[Group n] Simple Timer	0 = Deactivate; 1 = Activate

21, 32, 43, 54, 65, 76, 87, 98, 109, 120, 131, 142, 153, 164, 175, 186, 197, 208, 219, 230, 241, 252, 263, 274, 285, 296, 307, 318, 329, 340, 351, 362	1 Bit	I	C - - W -	DPT_Start	0/1	[Group n] Flashing	0 = Deactivate; 1 = Activate
22, 33, 44, 55, 66, 77, 88, 99, 110, 121, 132, 143, 154, 165, 176, 187, 198, 209, 220, 231, 242, 253, 264, 275, 286, 297, 308, 319, 330, 341, 352, 363	1 Bit	I	C - - W -	DPT_Enable	0/1	[Group n] Lock	0 = Unlock; 1 = Lock
23, 34, 45, 56, 67, 78, 89, 100, 111, 122, 133, 144, 155, 166, 177, 188, 199, 210, 221, 232, 243, 254, 265, 276, 287, 298, 309, 320, 331, 342, 353, 364	1 Bit	I	C - - W -	DPT_Enable	0/1	[Group n] Burn-in Mode	0 = Stop Burn-in ; 1 = Start Burn-in
24, 35, 46, 57, 68, 79, 90, 101, 112, 123, 134, 145, 156, 167, 178, 189, 200, 211, 222, 233, 244, 255, 266, 277, 288, 299, 310, 321, 332, 343, 354, 365	1 Bit	O	C T R - -	DPT_Enable	0/1	[Group n] Burn-in Mode (Status)	0 = Burn-in Inactive; 1 = Burn-in Active
366, 370, 374, 378, 382, 386, 390, 394, 398, 402, 406, 410, 414, 418, 422, 426, 430, 434, 438, 442, 446, 450, 454, 458, 462, 466, 470, 474, 478, 482, 486, 490, 494, 498, 502, 506, 510, 514, 518, 522, 526, 530, 534, 538, 542, 546, 550, 554, 558, 562, 566, 570, 574, 578, 582, 586,	4 Bytes	I/O	C T R W -	DPT_Value_4_Ucount	0 - 1.000.000	[ECG n] Operating Time	Time in Hours



590, 594, 598, 602, 606, 610, 614, 618							
622	1 Bit		CT---	DPT_Trigger	0/1	[Heartbeat] Object to Send '1'	Sending of '1' Periodically

Join and send us your inquiries  
about Zennio devices:

<http://support.zennio.com>

**Zennio Avance y Tecnología S.L.**

C/ Río Jarama, 132. Nave P-8.11  
45007 Toledo (Spain).

*Tel. +34 925 232 002*

*www.zennio.com*  
*info@zennio.com*



RoHS