

Heating Actuators in the MIX2 Series

HMG 6 T, HME 6 T

FIX1 HM 6 T

FIX2 HM 12 T

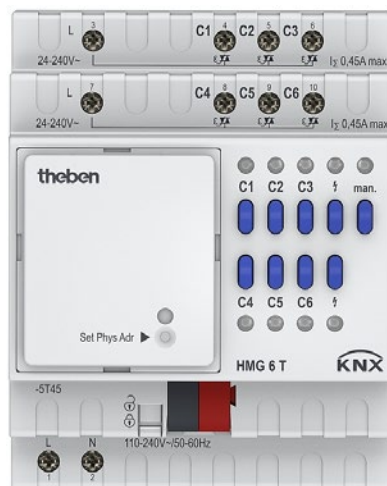

HMG 6 T	4930240
HME 6 T	4930245
HM 6 T	4940240
HM 12 T	4940245

Contents

1 Contents

2	<i>FUNCTIONAL CHARACTERISTICS</i>	3
3	<i>MIX2 AND FIX1/FIX2 DEVICES</i>	4
4	<i>MIX AND MIX2 DEVICES</i>	4
4.1	OPERATION.....	5
5	<i>TECHNICAL DATA</i>	6
6	<i>THE APPLICATION PROGRAM "MIX2 V1.B" (V1.11)</i>	7
6.1	SELECTION IN THE PRODUCT DATABASE.....	7
6.2	COMMUNICATION OBJECTS	8
6.2.1	<i>Channel- and module-related objects</i>	8
6.2.2	<i>Common objects</i>	14
6.2.3	<i>Description of objects</i>	15
6.3	PARAMETER.....	23
6.3.1	<i>Parameter pages</i>	23
6.3.2	<i>General</i>	24
6.3.3	<i>Parameters for the heating actuator</i>	26
6.3.4	<i>Parameters for the heating controller</i>	33
7	<i>TYPICAL APPLICATIONS</i>	48
7.1	SIMPLE CONTROL WITH ONE HMG 6 T CHANNEL AS HEATING ACTUATOR	48
7.1.1	<i>Devices:</i>	48
7.1.2	<i>Overview</i>	48
7.1.3	<i>Objects and links</i>	49
7.1.4	<i>Important parameter settings</i>	50
7.2	SCHOOL LOCATION : HMG 6 T AS HEATING CONTROLLER WITH AUTOMATIC SUMMER MODE. 52	
7.2.1	<i>Devices:</i>	52
7.2.2	<i>Overview</i>	53
7.2.3	<i>Objects and links</i>	54
7.2.4	<i>Important parameter settings</i>	56
8	<i>APPENDIX</i>	57
8.1	DETERMINING THE CURRENT OPERATING MODE	57
8.1.1	<i>Determining the setpoint value</i>	58
8.2	SETPOINT OFFSET.....	60
8.3	BASE SETPOINT VALUE AND CURRENT SETPOINT VALUE	61
8.4	SHORT-CIRCUIT AND OVERCURRENT SHUTDOWN.....	62
8.5	LOAD DISTRIBUTION, CONNECTION OF DEVICES.....	62
8.6	CONVERSION OF PERCENTAGES TO HEXADECIMAL AND DECIMAL VALUES.....	63

2 Functional characteristics

- MIX2 6-channel heating actuator
- With 6 temperature controllers (P/PI) for heating and cooling
- MIX2 basic module
- For extension to maximum of 18 channels (MIX2)
- For controlling 6 thermal actuators 24 V - 230 V AC in 2 groups with 3 outputs and 450 mA each
- With short-circuit and overload protection
- Continuous or switching actuating value selectable
- Valve protection function can be deactivated
- With the modes: comfort, standby, night as well as frost/heating protection
- Changeover to summer mode possible
- Up to 2 MIX or MIX2 extension modules can be connected to a basic module
- Device and KNX bus module can be swapped independently of each other
- Removable KNX bus module enables devices to be changed without reprogramming
- Manual start-up and use of the actuators is possible even without the KNX bus module
- LED switching status indicator for each channel
- Manual operation on device (even without bus voltage)

3 MIX2 and FIX1/FIX2 Devices

This manual describes the MIX2 devices and can also be used with devices from the FIX2 Series.

A FIX1 device behaves like a MIX2 basic module.

A FIX2 device behaves like a MIX2 basic module and an extension module of the same type (e.g. blinds actuator) in a common housing.

Devices in the FIX Series (Order No. 494..):

- Cannot be extended
- Cannot be combined

The remaining functions are identical to those in the MIX2 Series.

4 MIX and MIX2 devices

The MIX2 Series consists of the basic modules RMG 4 I, RMG 8 S, RMG 8 T, DMG 2 T, JMG 4 T, JMG 4 T 24V, HMG 6 T + extensions RME 4 I, RME 8 S, RME 8 T, DME 2 T, JME 4 T, JME 4 T 24V, HMG 6 T (04.2014).

Any MiX and MIX2 extension modules can be connected to a MIX2 basic module.

Table 1

Appliance type	Order No.	Designation	Can be used with basic module...	
			in the MIX series	in the MIX2 series
MIX2 basic modules	493...	RMG 4 I, RMG 8 S, RMG 8 T, DMG 2 T, JMG 4 T, JMG 4 T 24V, HMG 6 T.	-	-
MIX2 upgrades	493...	RME 4 I, RME 8 S, RME 8 T, DME 2 T, JME 4 T, JME 4 T 24V, HME 6 T.	no	Yes
MIX basic modules	491...	BMG 6, DMG 2 S, HMG 4, JMG 4 S, RMG 4 S, RMG 4 C-Last, SMG 2 S	-	-
MIX upgrades	491...	BME 6, DME 2 S, HME 4, JME 4 S, RME 4 S, RME 4 C-load, SME 2 S	yes	Yes*

* Adjusted parameter display and object numbering.

4.1 Operation

Each module has a manual button.

When manual mode is activated, the device can only be operated with the buttons; bus telegrams are not implemented.

A button and an LED are available for each channel.
The LEDs show the current state of the output.

In standard operation:

Case 1, channel is off:

Pressing the channel button switches on the output for 5 **minutes**.

Case 2, channel is already on:

Pressing the channel button switches the output off for 5 **seconds**.

During this time (5 minutes. or 5 seconds), bus telegrams are ignored.
The device then returns to normal operation.

In manual mode with the manual button or *Manual* object:

In the manual mode, the buttons can be used to switch the channels on or off as desired.
The time limits for normal operation (5 min. and 5 s) do not apply in this case.

If the "manual" function is selected, the associated LED lights up.
The channel status will be frozen and can only be changed via the channel buttons.
Bus telegrams will not be implemented.

The "Manual" state will be cancelled during a mains failure.
After manual operation has been cancelled, already-received bus events will not be executed again.

5 Technical data

Operating voltage KNX	Bus voltage, ≤ 4 mA
Operating voltage	110 – 240 V AC
Frequency	50 – 60 Hz
Standby output	0,3 W / 0,5W ¹
Width	4 module / 8 module ¹
Installation type	DIN-rail
Number of channels	6 / 12 ¹
Connection type	Terminals screws
Max. cable cross-section	Solid: 0.5 mm ² (Ø 0.8) to 4 mm ² strand with crimp terminal: 0.5 mm ² to 2.5 mm ²
Output	Triac C1-C3: I _Σ 0,45 A max. C4-C6: I _Σ 0,45 A max. C7-C9: I _Σ 0,45 A max. ¹ C10-C12: I _Σ 0,45 A max. ¹
Switch output	Floating
Voltage output	24 V AC – 240 V AC
Suitable for SELV	Yes, if all channels switch SELV
Switching of different phases	Possible
Ambient temperature	-5 °C ... +45 °C
Protection rating	IP 20
Protection class	II in accordance with EN 60 730-1

¹ HM 12 T

6 The application program "MIX2 V1.B" (V1.11)

6.1 Selection in the product database

Manufacturer	Theben AG
Product family	Heating actuators
Product type	HMG 6 T
Program name	MIX2 V1.B

The ETS database can be found on our website: www.theben.de/en/downloads_en

Table 2

Number of communication objects:	254
Number of group addresses:	254
Number of associations:	255

6.2 Communication Objects

The objects are divided into channel-related and common objects

6.2.1 Channel- and module-related objects

Table 3

No.	Object name	Function	Length DPT	Flags			
				C	R	W	T
0	<i>HMG 6 T Channel H1</i>	<i>Base setpoint value</i>	2 byte 9.001	C	R	W	-
		<i>Switching actuating value</i>	1 bit 1.001	C	R	W	-
		<i>Continuous actuating value</i>	1 byte 5.001	C	R	W	-
1	<i>HMG 6 T Channel H1</i>	<i>Manual setpoint offset</i>	2 byte 9.002	C	R	W	-
2	<i>HMG 6 T Channel H1</i>	<i>Actual value</i>	2 byte 9.001	C	R	W	-
		<i>Block valve protection</i>	1 bit 1.003	C	R	W	-
3	<i>HMG 6 T Channel H1</i>	<i>Current actuating value</i>	1 byte 5.001	C	R	-	T
		<i>Operating mode preset</i>	1 byte 20.102	C	R	W	-
4	<i>HMG 6 T Channel H1</i>	<i>Presence</i>	1 bit 1.018	C	R	W	-
5	<i>HMG 6 T Channel H1</i>	<i>Window position</i>	1 bit 1.019	C	R	W	-
6	<i>HMG 6 T Channel H1</i>	<i>Current operating mode</i>	1 byte 20.102	C	R	-	T
7	<i>HMG 6 T Channel H1</i>	<i>Heating actuating value</i>	1 byte 5.001	C	R	-	T
		<i>Heating and cooling actuating value</i>	1 byte 5.001	C	R	-	T
8	<i>HMG 6 T Channel H1</i>	<i>Cooling actuating value</i>	1 byte 5.001	C	R	-	T
9	<i>HMG 6 T Channel H1</i>	<i>Heating = 0, cooling = 1</i>	1.001	C	R	W	-
		<i>Heating = 1, cooling = 0</i>	1.100	C	R	W	-
		<i>Forced operation mode</i>	1 bit 1.003	C	R	W	-
10	<i>HMG 6 T Channel H1</i>	<i>Current setpointvalue</i>	2 byte 9.001	C	R	W	T
11	<i>HMG 6 T Channel H1</i>	<i>Report actual value failure</i>	1 bit 1.005	C	R	-	T
		<i>Report actuating value failure</i>	1 bit 1.005	C	R	-	T

Continuation:

No.	Object name	Function	Length DPT	Flags			
				C	R	W	T
12	<i>HMG 6 T Channel H2</i>	<i>Base setpoint value</i>	2 byte 9.001	C	R	W	-
		<i>Switching actuating value</i>	1 bit 1.001	C	R	W	-
		<i>Continuous actuating value</i>	1 byte 5.001	C	R	W	-
13	<i>HMG 6 T Channel H2</i>	<i>Manual setpoint offset</i>	2 byte 9.002	C	R	W	-
14	<i>HMG 6 T Channel H2</i>	<i>Actual value</i>	2 byte 9.001	C	R	W	-
		<i>Block valve protection</i>	1 bit 1.003	C	R	W	-
15	<i>HMG 6 T Channel H2</i>	<i>Current actuating value</i>	1 byte 5.001	C	R	-	T
		<i>Operating mode preset</i>	1 byte 20.102	C	R	W	-
16	<i>HMG 6 T Channel H2</i>	<i>Presence</i>	1 bit 1.018	C	R	W	-
17	<i>HMG 6 T Channel H2</i>	<i>Window position</i>	1 bit 1.019	C	R	W	-
18	<i>HMG 6 T Channel H2</i>	<i>Current operating mode</i>	1 byte 20.102	C	R	-	T
19	<i>HMG 6 T Channel H2</i>	<i>Heating actuating value</i>	1 byte 5.001	C	R	-	T
		<i>Heating and cooling actuating value</i>	1 byte 5.001	C	R	-	T
20	<i>HMG 6 T Channel H2</i>	<i>Cooling actuating value</i>	1 byte 5.001	C	R	-	T
21	<i>HMG 6 T Channel H2</i>	<i>Heating = 0, cooling = 1</i>	1.001	C	R	W	-
		<i>Heating = 1, cooling = 0</i>	1.100	C	R	W	-
		<i>Forced operation mode</i>	1 bit 1.003	C	R	W	-
22	<i>HMG 6 T Channel H2</i>	<i>Current setpointvalue</i>	2 byte 9.001	C	R	W	T
23	<i>HMG 6 T Channel H2</i>	<i>Report actual value failure</i>	1 bit 1.005	C	R	-	T
		<i>Report actuating value failure</i>	1 bit 1.005	C	R	-	T
24	<i>HMG 6 T Channel H3</i>	<i>Base setpoint value</i>	2 byte 9.001	C	R	W	-
		<i>Switching actuating value</i>	1 bit 1.001	C	R	W	-
		<i>Continuous actuating value</i>	1 byte 5.001	C	R	W	-
25	<i>HMG 6 T Channel H3</i>	<i>Manual setpoint offset</i>	2 byte 9.002	C	R	W	-
26	<i>HMG 6 T Channel H3</i>	<i>Actual value</i>	2 byte 9.001	C	R	W	-
		<i>Block valve protection</i>	1 bit 1.003	C	R	W	-

Continuation:

No.	Object name	Function	Length DPT	Flags			
				C	R	W	T
27	<i>HMG 6 T Channel H3</i>	<i>Current actuating value</i>	1 byte 5.001	C	R	-	T
		<i>Operating mode preset</i>	1 byte 20.102	C	R	W	-
28	<i>HMG 6 T Channel H3</i>	<i>Presence</i>	1 bit 1.018	C	R	W	-
29	<i>HMG 6 T Channel H3</i>	<i>Window position</i>	1 bit 1.019	C	R	W	-
30	<i>HMG 6 T Channel H3</i>	<i>Current operating mode</i>	1 byte 20.102	C	R	-	T
31	<i>HMG 6 T Channel H3</i>	<i>Heating actuating value</i>	1 byte 5.001	C	R	-	T
		<i>Heating and cooling actuating value</i>	1 byte 5.001	C	R	-	T
32	<i>HMG 6 T Channel H3</i>	<i>Cooling actuating value</i>	1 byte 5.001	C	R	-	T
33	<i>HMG 6 T Channel H3</i>	<i>Heating = 0, cooling = 1</i>	1.001	C	R	W	-
		<i>Heating = 1, cooling = 0</i>	1.100	C	R	W	-
		<i>Forced operation mode</i>	1 bit 1.003	C	R	W	-
34	<i>HMG 6 T Channel H3</i>	<i>Current setpointvalue</i>	2 byte 9.001	C	R	W	T
35	<i>HMG 6 T Channel H3</i>	<i>Report actual value failure</i>	1 bit 1.005	C	R	-	T
		<i>Report actuating value failure</i>	1 bit 1.005	C	R	-	T
36	<i>HMG 6 T Channel H4</i>	<i>Base setpoint value</i>	2 byte 9.001	C	R	W	-
		<i>Switching actuating value</i>	1 bit 1.001	C	R	W	-
		<i>Continuous actuating value</i>	1 byte 5.001	C	R	W	-
37	<i>HMG 6 T Channel H4</i>	<i>Manual setpoint offset</i>	2 byte 9.002	C	R	W	-
38	<i>HMG 6 T Channel H4</i>	<i>Actual value</i>	2 byte 9.001	C	R	W	-
		<i>Block valve protection</i>	1 bit 1.003	C	R	W	-
39	<i>HMG 6 T Channel H4</i>	<i>Current actuating value</i>	1 byte 5.001	C	R	-	T
		<i>Operating mode preset</i>	1 byte 20.102	C	R	W	-
40	<i>HMG 6 T Channel H4</i>	<i>Presence</i>	1 bit 1.018	C	R	W	-
41	<i>HMG 6 T Channel H4</i>	<i>Window position</i>	1 bit 1.019	C	R	W	-
42	<i>HMG 6 T Channel H4</i>	<i>Current operating mode</i>	1 byte 20.102	C	R	-	T

Continuation:

No.	Object name	Function	Length DPT	Flags			
				C	R	W	T
43	<i>HMG 6 T Channel H4</i>	<i>Heating actuating value</i>	1 byte 5.001	C	R	-	T
		<i>Heating and cooling actuating value</i>	1 byte 5.001	C	R	-	T
44	<i>HMG 6 T Channel H4</i>	<i>Cooling actuating value</i>	1 byte 5.001	C	R	-	T
45	<i>HMG 6 T Channel H4</i>	<i>Heating = 0, cooling = 1</i>	1.001	C	R	W	-
		<i>Heating = 1, cooling = 0</i>	1.100	C	R	W	-
		<i>Forced operation mode</i>	1 bit 1.003	C	R	W	-
46	<i>HMG 6 T Channel H4</i>	<i>Current setpointvalue</i>	2 byte 9.001	C	R	W	T
47	<i>HMG 6 T Channel H4</i>	<i>Report actual value failure</i>	1 bit 1.005	C	R	-	T
		<i>Report actuating value failure</i>	1 bit 1.005	C	R	-	T
48	<i>HMG 6 T Channel H5</i>	<i>Base setpoint value</i>	2 byte 9.001	C	R	W	-
		<i>Switching actuating value</i>	1 bit 1.001	C	R	W	-
		<i>Continuous actuating value</i>	1 byte 5.001	C	R	W	-
49	<i>HMG 6 T Channel H5</i>	<i>Manual setpoint offset</i>	2 byte 9.002	C	R	W	-
50	<i>HMG 6 T Channel H5</i>	<i>Actual value</i>	2 byte 9.001	C	R	W	-
		<i>Block valve protection</i>	1 bit 1.003	C	R	W	-
51	<i>HMG 6 T Channel H5</i>	<i>Current actuating value</i>	1 byte 5.001	C	R	-	T
51	<i>HMG 6 T Channel H5</i>	<i>Operating mode preset</i>	1 byte 20.102	C	R	W	-
52	<i>HMG 6 T Channel H5</i>	<i>Presence</i>	1 bit 1.018	C	R	W	-
53	<i>HMG 6 T Channel H5</i>	<i>Window position</i>	1 bit 1.019	C	R	W	-
54	<i>HMG 6 T Channel H5</i>	<i>Current operating mode</i>	1 byte 20.102	C	R	-	T
55	<i>HMG 6 T Channel H5</i>	<i>Heating actuating value</i>	1 byte 5.001	C	R	-	T
		<i>Heating and cooling actuating value</i>	1 byte 5.001	C	R	-	T
56	<i>HMG 6 T Channel H5</i>	<i>Cooling actuating value</i>	1 byte 5.001	C	R	-	T
57	<i>HMG 6 T Channel H5</i>	<i>Heating = 0, cooling = 1</i>	1.001	C	R	W	-
		<i>Heating = 1, cooling = 0</i>	1.100	C	R	W	-
		<i>Forced operation mode</i>	1 bit 1.003	C	R	W	-
58	<i>HMG 6 T Channel H5</i>	<i>Current setpointvalue</i>	2 byte 9.001	C	R	W	T

Continuation:

No.	Object name	Function	Length DPT	Flags			
				C	R	W	T
59	<i>HMG 6 T Channel H5</i>	<i>Report actual value failure</i>	1 bit 1.005	C	R	-	T
		<i>Report actuating value failure</i>	1 bit 1.005	C	R	-	T
60	<i>HMG 6 T Channel H6</i>	<i>Base setpoint value</i>	2 byte 9.001	C	R	W	-
		<i>Switching actuating value</i>	1 bit 1.001	C	R	W	-
		<i>Continuous actuating value</i>	1 byte 5.001	C	R	W	-
61	<i>HMG 6 T Channel H6</i>	<i>Manual setpoint offset</i>	2 byte 9.002	C	R	W	-
62	<i>HMG 6 T Channel H6</i>	<i>Actual value</i>	2 byte 9.001	C	R	W	-
		<i>Block valve protection</i>	1 bit 1.003	C	R	W	-
63	<i>HMG 6 T Channel H6</i>	<i>Current actuating value</i>	1 byte 5.001	C	R	-	T
		<i>Operating mode preset</i>	1 byte 20.102	C	R	W	-
64	<i>HMG 6 T Channel H6</i>	<i>Presence</i>	1 bit 1.018	C	R	W	-
65	<i>HMG 6 T Channel H6</i>	<i>Window position</i>	1 bit 1.019	C	R	W	-
66	<i>HMG 6 T Channel H6</i>	<i>Current operating mode</i>	1 byte 20.102	C	R	-	T
67	<i>HMG 6 T Channel H6</i>	<i>Heating actuating value</i>	1 byte 5.001	C	R	-	T
		<i>Heating and cooling actuating value</i>	1 byte 5.001	C	R	-	T
68	<i>HMG 6 T Channel H6</i>	<i>Cooling actuating value</i>	1 byte 5.001	C	R	-	T
69	<i>HMG 6 T Channel H6</i>	<i>Heating = 0, cooling = 1</i>	1.001	C	R	W	-
		<i>Heating = 1, cooling = 0</i>	1.100	C	R	W	-
		<i>Forced operation mode</i>	1 bit 1.003	C	R	W	-
70	<i>HMG 6 T Channel H6</i>	<i>Current setpointvalue</i>	2 byte 9.001	C	R	W	T
71	<i>HMG 6 T Channel H6</i>	<i>Report actual value failure</i>	1 bit 1.005	C	R	-	T
		<i>Report actuating value failure</i>	1 bit 1.005	C	R	-	T
72	<i>HMG 6 T</i>	<i>Summer mode ON/OFF</i>	1 bit 1.003	C	R	W	-
73	<i>HMG 6 T</i>	<i>Overcurr./short circuit H1-H3</i>	1 bit 1.005	C	R	-	T
74	<i>HMG 6 T</i>	<i>Overcurr./short circuit H4-H6</i>	1 bit 1.005	C	R	-	T
75	<i>HMG 6 T</i>	<i>Highest actuating value</i>	1 byte 5.001	C	R	-	T

Continuation:

No.	Object name	Function	Length DPT	Flags			
				C	R	W	T
76	<i>HMG 6 T</i>	<i>Pump ON/OFF</i>	1 bit 1.001	C	R	-	T
77	<i>HMG 6 T</i>	<i>Outside temperature</i>	2 byte 9.001	C	R	W	-
78	<i>HMG 6 T</i>	<i>Manual</i>	1 bit 1.001	C	R	W	T
79	<i>HMG 6 T</i>	<i>Outside temperature failure</i>	1 bit 1.005	C	R	-	T

Table 4: Overview of channel- and module-related objects

Basic module HMG 6 T						1st extension HME 6 T						2st extension HME 6 T					
C1	C2	C3	C4	C5	C6	C1	C2	C3	C4	C5	C6	C1	C2	C3	C4	C5	C6
0	12	24	36	48	60	80	92	104	116	128	140	160	172	184	196	208	220
1	13	25	37	49	61	81	93	105	117	129	141	161	173	185	197	209	221
2	14	26	38	50	62	82	94	106	118	130	142	162	174	186	198	210	222
3	15	27	39	51	63	83	95	107	119	131	143	163	175	187	199	211	223
4	16	28	40	52	64	84	96	108	120	132	144	164	176	188	200	212	224
5	17	29	41	53	65	85	97	109	121	133	145	165	177	189	201	213	225
6	18	30	42	54	66	86	98	110	122	134	146	166	178	190	202	214	226
7	19	31	43	55	67	87	99	111	123	135	147	167	179	191	203	215	227
8	20	32	44	56	68	88	100	112	124	136	148	168	180	192	204	216	228
9	21	33	45	57	69	89	101	113	125	137	149	169	181	193	205	217	229
10	22	34	46	58	70	90	102	114	126	138	150	170	182	194	206	218	230
11	23	35	47	59	71	91	103	115	127	139	151	171	183	195	207	219	231
72						152						232					
73						153						233					
74						154						234					
75						155						235					
76						156						236					
77						157						237					
78						158						238					
79						159						239					

6.2.2 Common objects

These objects are partly used by the basic module and the two extension modules.

Table 5:

No.	Object name	Function	Type DPT	Flags			
				C	R	W	T
240	<i>Central continuous ON</i>	<i>For RMG 8S, DME 2 S, SME 2 S, DMG 2 T, DME 2 T</i>	1 bit 1.001	C	R	W	T
241	<i>Central continuous OFF</i>	<i>For RMG 8S, DME 2S, SME 2S, DMG 2 T, DME 2 T</i>	1 bit 1.001	C	R	W	T
242	<i>Central switching</i>	<i>For RMG8S, DME 2S, SME 2S, DMG 2 T, DME 2 T</i>	1 bit 1.001	C	R	W	T
243	<i>Call up/save central scenes</i>	<i>RMG8S, DME2S, JME4S, SME2S, DMG 2 T, DME 2 T</i>	1 byte 18.001	C	R	W	T
244	<i>Central safety 1</i>	<i>For JMG 4 T (Wind), JME 4 S</i>	1 bit 1.005	C	R	W	-
245	<i>Central safety 2</i>	<i>For JMG 4 T (Wind), JME 4 S</i>	1 bit 1.005	C	R	W	-
246	<i>Central safety 3</i>	<i>For JMG 4 T (Wind), JME 4 S</i>	1 bit 1.005	C	R	W	-
247	<i>Central up/down</i>	<i>For JMG 4 T, JME 4 S</i>	1 bit 1.008	C	R	W	-
248	<i>Central safety rain</i>	<i>For JMG 4 T</i>	1 bit 1.005	C	R	W	-
249	<i>Central safety frost</i>	<i>For JMG 4 T</i>	1 bit 1.005	C	R	W	-
250	<i>Version of bus coupling unit</i>	<i>transmit</i>	14 byte 16.001	C	R	-	T
251	<i>Version of basic module</i>	<i>transmit</i>	14 byte 16.001	C	R	-	T
252	<i>Version of first extension module</i>	<i>transmit</i>	14 byte 16.001	C	R	-	T
253	<i>Version of second extension module</i>	<i>transmit</i>	14 byte 16.001	C	R	-	T

6.2.3 Description of objects

The function of the channel, i.e. *heating actuator* or *heating controller* determines the type and function of the objects.

6.2.3.1 Objects for the heating actuator function

- **Object 0** "*Continuous actuating value, switching actuating value*"

The actuating value receives data from the room thermostat for the corresponding valve. It can either be continuous (0-100%) or switching (ON/OFF) depending on the configuration.

- **Object 1**

Not used.

- **Object 2** „Block valve protection“

Blocks the valve protection function.

- **Object 3** "*Current actuating value*"

Reports the actual value of the actuating value generated for the channel.

- **Objects 4, 5, 6, 7, 8, 9, 10**

Not used.

- **Object 11** "*Report actuating value failure*"

Present only if, on the *Configuration options* parameter page, the parameter *Monitor the actuating value* = *yes*.

If monitoring is selected, the room thermostat must receive an actuating-value telegram regularly. Recommendation: To ensure trouble-free operation, the cyclical transmission time to the room thermostat should be no longer than half the monitoring time.

Example: Monitoring time 30 min, cyclical transmission time to thermostat less than or equal to 15 min.

If no new actuating value is received within the configured monitoring time, failure of the room thermostat is assumed and an emergency program is started.

See emergency program parameter page.

This function can be selected or deactivated individually for each channel.

The monitoring time is set jointly for all channels on the *Channel H1-H6 monitoring* page.

6.2.3.2 Objects for the heating controller function

- **Object 0 "Base setpoint value"**

The Base setpoint value value is first specified via the application at start-up and stored in the "Base setpoint value" object.

It can be reset at any time using object 0 (limited by minimum or maximum valid setpoint value).

The object can be described as required.

- **Object 1 "Manual setpoint offset"**

Offset setpoint temperature:

The object receives a temperature difference as DPT 9.002 . The desired room temperature (current setpoint value) can be adjusted from the base setpoint value by this difference.

The following applies in comfort mode (heating):

Current setpoint value (obj. 10) = base setpoint value + manual setpoint offset (obj. 1)

Values beyond the configured range (*maximum or minimum valid setpoint value on the setpoint values parameter page*) are limited to the highest or lowest value.

Remarks:

The offset is always in relation to the set *base setpoint value* and not to the current setpoint value.

See also: [Determining the setpoint value](#)

- **Object 2 „Actual value“**

Receives the current room temperature for the control.

- **Object 3 "Operating mode"**

1 byte object. One of 4 operating modes can be directly activated.

1 = Comfort, 2 = Standby, 3 = Night,

4 = Frost protection (heat protection)

If another value is received (0 or >4) the comfort operation mode is activated.

The details in brackets refer to cooling mode

- **Object 4 "Presence"**

The status of a presence detector (e.g. push button, motion detector) can be received via this object.

1 on this object activates the comfort operating mode.

- **Object 5 "Window"**

The status of a window contact can be received via this object.

1 on this object activates the frost / heat protection operating mode.

- **Object 6 "Current operating mode"**

Transmits the current operation mode as a 1 byte value (see table).
The transmission behaviour can be set on the *Operating mode* parameter page.

Table 6: Coding of HVAC operating modes:

Value	select
1	Comfort
2	Standby
3	Night
4	Frost protection/heat protection

- **Object 7 "Heating actuating value, heating and cooling actuating value"**

Sends the current heating actuating value (0...100%), or heating or cooling if the *Output of cooling actuating value* parameter has been set to *Together with heating actuating value*.

- **Object 8 "Cooling actuating value"**

Sends the cooling actuating value or switching command to control a cooling surface, fan coil unit etc.
The send format DPT 5.001 or DPT 1.001 depends on the selected *Type of control* (continuous or switching) on the *Cooling control* page.

Note:

Object 8 is not available:

- With the setting *Heating control only* (*Settings* parameter page), as cooling function is not available.
- If *Changeover between heating and cooling* → *via object* is selected and *Output of cooling actuating value* is set to *Together with heating actuating value* (*Cooling control* parameter page).

- **Object 9 "Changeover between heating and cooling", "forced operation"**

The function of the object depends on the setting of the *Changeover between heating and cooling* parameter on the *Cooling control* parameter page.

Table 7

<i>Switchover between heating and cooling</i>							
<i>Automatic</i>	<i>Via object</i>						
Forced operation. The direction of action of the force telegram is adjustable. Standard: 1 = activate force 0 = end force.	This object is used in 2-pipe heating/cooling systems or if automatic change over between heating and cooling is not desired. The telegram format can be set on the cooling control parameter page:						
	<table border="1"> <thead> <tr> <th>Parameter: Format object heating/cooling</th> <th>Telegram format</th> </tr> </thead> <tbody> <tr> <td>DPT1.100</td> <td>Heating = 1, cooling = 0</td> </tr> <tr> <td>Inverted</td> <td>Heating = 0, cooling = 1</td> </tr> </tbody> </table>	Parameter: Format object heating/cooling	Telegram format	DPT1.100	Heating = 1, cooling = 0	Inverted	Heating = 0, cooling = 1
Parameter: Format object heating/cooling	Telegram format						
DPT1.100	Heating = 1, cooling = 0						
Inverted	Heating = 0, cooling = 1						

- **Object 10** "*Current setpoint value*"

Sends the current setpoint value in DPT 9.001 format to the bus.

- **Object 11** "*Actual value failure*"

Sends a 1 if no valid actual value was received during the monitoring time.

- **Objects 12-71**

Objects for channels H2-H6.

6.2.3.3 Common objects

- **Object 72** "*Summer mode*"

When 1 is set for the object, all channels configured for it are switched over to the summer mode and heating no longer takes place.

A valve protection program can also optionally be executed in the summer mode.

- **Object 73** "*Overcurrent/short circuit H1-H3*"

Reports overload or short circuit on channels H1, H2, H3.

0 = No error

1 = Overload or short circuit on at least one of the 3 channels H1-H3

- **Object 74** "*Overcurrent/short circuit H4..H6*"

0 = No error

1 = Overload or short circuit on at least one of the 3 channels H4-H6

- **Object 75** "*Highest actuating value*"

This object is available if at least 1 channel was configured as a continuous controller.

The actuating values for the channels are continuously compared with each other and only the highest current value is sent to this object.

The current heat requirement of the system is thus constantly reported to the heating boiler, which then adapts its output to the actual requirement.

Whether a channel is taken into account for determining the highest actuating value can be selected individually for each channel. For example, insignificant rooms can be ignored for the heat requirement.

- **Object 76** "*Pump*"

Control of the supply pump. This object is used jointly for all channels of a module.

- **Object 77** "*Outside temperature*"

Receives the outside temperature.

- **Object 78 "Manual"**

Only available for devices in the MIX2 series (order number 493...)

Puts the relevant module in manual mode or sends the status of the manual operation.

Table 8

Telegram	Meaning	Explanation
0	Auto	All channels can be operated via the bus as well as via the buttons.
1	Manual	The channels can only be operated via the buttons on the device. Bus telegrams will not work.

The duration of the manual mode, i.e. *operation of the manual button* is adjustable on the *General* parameter page.

After manual operation has been cancelled, already-received bus events will not be executed again. The "Manual" state will be reset in the event of a mains failure.

- **Object 79 "Outside temperature failure"**

0 = No error

1 = Error: Outside temperature no longer being received.

- **Objects 80-159**

Objects for the first extension module HME 6 T.

- **Objects 160-239**

Objects for the second extension module HME 6 T.

- **Objects 240 - 249**

Not used for HMG 6 T and HME 6 T.

- **Object 250** "*Version of bus coupling unit*"

For diagnostic purposes only.

Sends the bus coupling unit software version after reset or download.
Can also be read out via the ETS.

Format: **Axx Hyy Vzzz**

Code	Meaning
xx	00 .. FF = Version of application without dividing point (14 = V1.4, 15 = V1.5 etc.).
yy	Hardware version 00..99
zzz	Firmware version 000..999

EXAMPLE: A15 H03 V014

- ETS Application Version 1.5
- Hardware version \$03
- Firmware version \$14

- **Object 251** "*Version of basic module*"

For diagnostic purposes only.

Only for basic modules in the MIX2 series (order number 493...).

Sends the software version (firmware) of the basic module after reset or download.
Can also be read out via the ETS.

The version is issued as an ASCII character string.

Format: **Mxx Hyy Vzzz**

Code	Meaning
xx	01 .. FF = Module code (hexadecimal).
yy	Hardware version 00..99
zzz	Firmware version 000..999

Possible module codes (04.2014)

Module	Code
Module or mains voltage are unavailable.	\$00
RMG 8 S	\$11
RMG 4 I	\$12
DMG 2 T	\$13
JMG 4 T/JMG 4 T 24V	\$14
HMG 6 T	\$15
RMG 8 T	\$17

EXAMPLE: M15 H25 V025

- Module \$15 = HMG 6 T
- Hardware version V25
- Firmware version V25

- **Object 252** "*Version of first extension module*"

Telegram format: See above, object 251

Possible module codes (04.2014)

Module	Code
Module or mains voltage are unavailable.	\$00
RME 8 S	\$11
RME 4 I	\$12
DME 2 T	\$13
JME 4 T/JME 4 T 24V	\$14
HME 6 T	\$15
RME 8 T	\$17

- **Object 253** "*Version of second extension module*"

See above, object 252

6.3 Parameter

6.3.1 Parameter pages

The HMG 6 T heating actuator has 6 identical channels that can be configured individually as actuator or controller.

Table 9

Function	Description
<i>General</i>	Selection of module and central parameters.
<i>BASIC MODULE: HMG 6 T</i>	(Empty page).
<i>HMG 6 T Channel H1 Configuration options</i>	Selection as heating controller / heating actuator and activation of additional functions.
<i>Settings</i>	Standard/user-defined control.
<i>Heating control</i>	Control parameters, installation type etc. for the heating mode.
<i>Setpoint values</i>	Base setpoint value, lowering, frost protection etc.
<i>Cooling control</i>	Control parameters, installation type etc. for the cooling mode.
<i>Cooling setpoint values</i>	Dead zone, standby, heat protection etc.
<i>Operating mode</i>	Operating mode after reset, presence sensor etc.
<i>Channel characteristics</i>	Parameters for actuator control.
<i>Emergency program</i>	Response to failure of the actuating value or the actual value.
<i>Forced operation</i>	Response in forced-operation mode.
<i>Channel H1-H6 monitoring</i>	Monitoring of actuating value, actual value, outside temperature.
<i>H1-H6 Pump</i>	Pump control strategy.

6.3.2 General

Table 10

Designation	Values	Description
<i>Type of basic module</i>	Select device... RMG 8 S.. RMG 8 T.. RMG 4 I.. DMG 2 T.. JMG 4 T/JMG 4 T 24V.. HMG 6 T..	Selection of available basic module (MIX2 series only)
<i>Type of first extension module</i>	not available/inactive RME 8 S.. RME 8 T.. RME 4 I.. DME 2 T.. JME 4 T/JME 4 T 24V.. HME 6 T.. RME 4 S / RME 4 C-Last.. DME 2 / SME 2.. BME 6.. JME 4 S.. HME 4..	Selection of first extension module, if available. (MIX or MIX2 series)
<i>Type of second extension module</i>	not available/inactive RME 8 S.. RME 8 T.. RME 4 I.. DME 2 T.. JME 4 T/JME 4 T 24V.. HME 6 T.. RME 4 S / RME 4 C-Last.. DME 2 / SME 2.. BME 6.. JME 4 S.. HME 4..	Selection of second extension module, if available. (MIX or MIX2 series)
<i>Time for cyclical sending of feedback object (MIX series, order no. 491...)</i>	2 minutes, 3 minutes, 5 minutes, 10 minutes, 15 minutes , 20 minutes, 30 minutes, 45 minutes, 60 minutes	This parameter is used exclusively for MIX Series extension modules (DME 2 S, SME 2, JME 4 S, BME 6, RME 4 S / C-Last, and HME 4).

Continuation:

Designation	Values	Description
<p><i>Function of manual button (MIX2 series, order no. 493...)</i></p>	<p><i>applies for 24 hours or until reset via object disabled</i></p> <p><i>applies until reset via object</i></p> <p><i>applies for 30 minutes or until reset via object</i></p> <p><i>applies for 1 hour or until reset via object</i></p> <p><i>applies for 2 hours or until reset via object</i></p> <p><i>applies for 4 hours or until reset via object</i></p> <p><i>applies for 8 hours or until reset via object</i></p> <p><i>applies for 12 hours or until reset via object</i></p>	<p>Determines how long the device works manually and how this is ended.</p> <p>In manual mode, the channels can only be switched on and off via the push buttons on the device. See also: Object 78</p> <p>This parameter is used exclusively for MIX2 series devices.</p>
<p><i>Manual operation of channels (MIX2 series, order no. 493...)</i></p>	<p><i>enabled</i></p> <p><i>disabled</i></p>	<p>The channels can be operated via the buttons on the device.</p> <p>No manual operation, the buttons on the device are locked.</p>

6.3.3 Parameters for the heating actuator

6.3.3.1 HMG 6 T Channel H1 Configuration options

Table 11

Designation	Values	Description
<i>Channel function</i>	<p>Heating actuator</p> <p><i>Heating controller</i></p>	<p>Should the channel be used as an actuator or controller?</p> <p>The channel receives its actuating value from an external room thermostat.</p> <p>The channel receives the room temperature over the bus and generates the actuating value independently by means of an internal controller. See chapter: Parameters for the heating actuator</p>
<i>Type of actuating value</i>	<p><i>switching..</i></p> <p><i>continuous..</i></p>	<p>The channel processes: ON/OFF telegrams.</p> <p>Percent telegrams 0-100%</p>
<i>Include in summer mode</i>	<p>no</p> <p>yes</p>	<p>Should the channel remain off in the summer mode?</p>
<i>Activate valve protection</i>	<p>no</p> <p>yes</p>	<p>This function prevents the valve from seizing and is executed if the valve position has not changed for 7 days. When this function is executed, the valve is moved to the opposite position for 6 minutes.</p> <p>No valve protection.</p> <p>Valve protection is active.</p>
<i>Valve protection disable telegram</i>	<p>1 = Block (standard)</p> <p>0 = Block</p>	<p>Valve protection is: blocked with a 1. blocked with a 0.</p>

Continuation:

Designation	Values	Description
<i>Monitor actuating value</i>	no yes..	Should whether the room thermostat regularly transmits an actuating value being monitored? A thermostat malfunction can be detected quickly in this way and an emergency program started.
<i>Activate forced-operation function</i>	no yes..	No forced-operation function. Opens the Forced-operation parameter page.

6.3.3.2 Channel characteristics

Table 12

Designation	Values	Description
<i>Time for one actuation cycle</i>	2, 3, 5, 7, 10 , 15, 20, 30 min	<p>For "continuous" actuating value.</p> <p>An actuation cycle consists of a switching-on and a switching-off process and forms a PWM period.</p> <p>Examples:</p> <ul style="list-style-type: none"> - Actuating value = 20%, - Time = 10 min. <p>means: switched on for 2 min. during the actuating cycle of 10 min. (i.e. 20% of actuating cycle) and switched off for 8 min.</p> <ul style="list-style-type: none"> - Actuating value = 70% / time = 10 min. <p>means: 7 min. on / 3 min. off. See appendix: PWM cycle</p>
<i>Actuator direction of operation</i>	<p>Standard: 1 = Open valve (Theben actuator)</p> <p><i>Inverted: 0 = Open valve</i></p>	<p>Standard. Valve closed when de-energised.</p> <p>Special inverted valve types. Valve open when de-energised.</p>
<i>Minimum actuating value</i>	0% , 5%, 10%, 20%, 30%	Lowest permissible actuating value
<i>Maximum actuating value</i>	50%, 60%, 70%, 80%, 90% , 100%	<p>Highest permissible actuating value.</p> <p>A highest value of 90% extends the service life of thermal actuators.</p> <p>A highest value of 100% reduces the number of switching cycles</p>

Continuation:

Designation	Values	Description
<p><i>Actuating value when value violates the min./max. actuating value</i></p>	<p style="text-align: center;"><i>0% or 100 %</i></p> <p style="text-align: center;"><i>Use set actuating values</i></p> <p style="text-align: center;"><i>0 = 0%; otherwise, use set actuating values</i></p> <p style="text-align: center;"><i>< Min. actuating value = 0 %, otherwise scale.</i></p>	<p>Restriction when a room thermostat receives an actuating value that is less than the minimum actuating value:</p> <p>Actuate channel with 0% or 100%</p> <p>Restrict values to maximum and minimum actuating values. For example, maintaining a minimum actuating value of 10% can be practical for the correct base temperature of an underfloor heating.</p> <p>If the received actuating value is = 0, accept this value and close the valve. Other values are restricted in acc. with the configured minimum and maximum actuating values: Received values > 0 % and < min. actuating value are replaced with the minimum actuating value. In the same way, values > max. actuating value are replaced with the set maximum actuating value.</p> <p>Actuating values below the minimum actuating values are interpreted as 0 %. Values above are scaled in proportion to the range between the min. actuating value and 100 %.</p>
<p><i>Send current actuating value</i></p>	<p style="text-align: center;"><i>With change of 1 %, 2 %, 3 %, 5 %, 7 %, 10 %, 15 %</i></p>	<p>After what percentage change* in the actuating value is the new value to be transmitted?</p>

*Change since last transmission.

Continuation:

Designation	Values	Description
<i>Send current actuating value cyclically</i>	not cyclical, only in the event of change, <i>Every 2 min., every 3 min. Every 5 min., every 10 min., every 15 min., every 20 min., every 30 min., every 45 min., every 60 min.</i>	Send when or at what interval?
<i>Take channel H1 into account for highest actuating value</i>	<i>no</i> <i>yes</i>	Should the actuating value for channel 1 be used for determining the highest actuating value of all channels?
<i>Take channel H1 into account for pump control</i>	<i>no</i> <i>yes</i>	Should the supply pump be switched on in case of heat requirement in channel 1?

6.3.3.3 Emergency program

Response to actuating value loss to ensure frost protection or minimum comfort in event of control failure.

Table 13

Designation	Values	Description
<i>Actuating value for emergency program is</i>	<i>fixed</i>	The valve is energised by a fixed actuating value continuously. See below: <i>Fixed emergency program in winter mode.</i>
	<i>Outside temperature dependent</i>	Energy-savings setting: The valve is energised on the basis of the outside temperature and in this way is opened only when it is really necessary.
<i>Actuating value for emergency program is fixed</i>		
<i>Fixed emergency program in winter mode</i>	0 %, 10 %, 20 % 30 %, 40 %, 50 %	Fixed actuating value that should replace the actuating value of the thermostat until it is available again.
<i>Actuating value for emergency program is temperature-dependent</i>		
<i>Emergency program active when outside temperature below</i>	5 °C 10 °C 15 °C	If the outside temperature drops below the said value, the valve opens.
<i>Max. actuating value in emergency program</i>	10 %, 20 % 30 %, 40 % , 50 %	What should be the maximum heating level in the emergency program?
<i>Fixed emergency program with failure of outside temperature.</i>	0 %, 10 %, 20 % 30 %, 40 %, 50 %	Fixed valve setting if neither the actuating value nor the outside temperature can be received.

6.3.3.4 Forced operation

Table 14

Designation	Values	Description
Actuating value in forced-operation mode	<i>0% to 100% in increments of 10%</i>	Set actuating value to control the valve in forced-operation mode. This is not restricted by the minimum or the maximum actuating value.
Forced-operation telegram	<i>1 = Forced operation (standard)</i>	Forced operation is activated with an ON telegram
	<i>0 = Forced operation</i>	Inverted: Forced operation is activated with an OFF telegram

6.3.4 Parameters for the heating controller

6.3.4.1 HMG 6 T Channel H1 Configuration options

Table 15

Designation	Values	Description
<i>Channel function</i>	<p><i>Heating actuator</i></p> <p><i>Heating controller</i></p>	<p>Should the channel be used as an actuator or controller?</p> <p>The channel receives its actuating value from an external room thermostat.</p> <p>The channel receives the room temperature over the bus and calculates the actuating value independently by means of an internal controller. See chapter: Parameters for the heating actuator</p>
<i>Include in summer mode</i>	<p><i>no</i></p> <p><i>yes</i></p>	Should the channel remain off in the summer mode?
<i>Execute valve protection</i>	<p><i>always</i></p> <p><i>only in comfort mode</i></p> <p><i>only in standby mode</i></p> <p><i>only in night mode</i></p>	<p>This function prevents the valve from seizing and is executed if the valve position has not changed for 7 days. When this function is executed, the valve is moved to the opposite position for 6 minutes.</p> <p>Valve protection is permitted at any time.</p> <p>Valve protection is permitted only during the operating mode selected here.</p>
<i>Monitor actual value</i>	<p><i>no</i></p> <p><i>yes</i></p>	<p>No monitoring.</p> <p>The actual value (room temperature) is monitored and an emergency program can be configured.</p>
<i>Activate forced-operation function</i>	<p><i>no</i></p> <p><i>yes</i></p>	<p>No forced-operation function.</p> <p>Opens the Forced-operation parameter page.</p>

6.3.4.2 Settings

Table 16

Designation	Values	Description
<i>CONTROL</i>	Standard	For simple applications (heating control only).
	<i>User-defined</i>	Enables selection of control functions.
<i>Control functions used</i>	Heating control only	User-defined control. Heating mode only.
	<i>Heating and cooling</i>	An additional cooling system will be controlled (object 8).

6.3.4.3 Heating control

Table 17

Designation	Values	Description
<i>Setting the control parameters</i>	Via system type	Standard application
	<i>user-defined</i>	Professional use: P/PI control self-configure
<i>System type</i>	Radiator heating system	PI control with: Integrated time = 90 minutes Bandwidth = 2.5 k
	<i>Underfloor heating</i>	Integrated time = 30 h Bandwidth = 4 k
<i>Send heating actuating value cyclically</i>	With change of 1 % With change of 2 % With change of 3 % With change of 5 % With change of 7 % With change of 10 % With change of 15 %	After how much % change* in the actuating value is the new value to be sent. Small values increase control accuracy but also the bus load.
<i>Cyclical Send heating actuating value cyclically</i>	not cyclical, only in the event of change Every 2 min, every 3 min. Every 5 min, every 10 min. Every 15 min, every 20 min. Every 30 min, every 45 min. Every 60 min.,	How often is the current heating actuating value to be sent (regardless of changes)?

Continuation:

Designation	Values	Description
User-defined parameter		
<i>Proportional band of heating control</i>	<i>1 K, 1.5 K, 2 K, 2.5 K, 3 K 3.5 K, 4 K, 4.5 K 5 K, 5.5 K, 6 K 6.5 K, 7 K, 7.5 K 8 K, 8.5 K</i>	Professional setting for adapting control response to the room. Small values cause large changes in actuating values, larger values cause finer actuating value adjustment.
<i>Integrated time of the heating control</i>	<i>pure P control 15 min, 30 min, 45 min. 60 min, 75 min, 90 min. 105 min, 120 min, 135 min. 150 min, 165 min, 180 min. 195 min, 210 min, 4 h, 5 h, 10 h 15 h, 20 h, 25 h, 30 h, 35 h</i>	The integrated time determines the reaction time of the control. It establishes the increase by which the actuating value from the controller is raised in addition to that from the P-term. The I-term remains active for as long as there is a control deviation. The I-term is added to the P-term.

*Change since last transmission

6.3.4.4 Setpoint values

Table 18

Designation	Values	Description
<i>Base setpoint value after loading the application</i>	<i>18 °C, 19 °C, 20 °C, 21 °C, 22 °C, 23 °C, 24 °C, 25 °C</i>	Output setpoint value for temperature control.
<i>Reduction in standby mode (during heating)</i>	<i>0.5 K, 1 K, 1.5 K 2 K, 2.5 K, 3 K 3.5 K, 4 K</i>	Example: With a base setpoint value of 21°C in the heating mode and a reduction of 2 K, controls HMG 6 T with a setpoint value of 21 – 2 = 19°C.
<i>Reduction in night mode (during heating)</i>	<i>3 K, 4 K, 5 K 6 K, 7 K, 8 K</i>	By what value should the temperature be reduced in night mode?
<i>Setpoint value for frost protection operation (during heating)</i>	<i>3 °C, 4 °C, 5 °C 6 °C, 7 °C, 8 °C, 9 °C, 10 °C</i>	Preset temperature for frost protection operation in heating mode (Heat protection operation applies in cooling mode).
<i>Setpoint offset only applies</i>	<i>only in comfort mode With comfort and standby mode With comfort, standby and night mode</i>	Setpoint value adjustment: Is only considered in the selected mode and is ineffective in all operation modes.

Continuation:

Designation	Values	Description
<i>Current setpoint value in comfort mode</i>	<p>Sends actual value (heating < > cooling)</p> <p><i>Transmits average value between heating and cooling</i></p>	<p>Feedback of current setpoint value via the bus:</p> <p>The setpoint value actually being used for control is always sent (= Current setpoint value). Example with Base setpoint value 21°C and Dead zone 2 K: During heating and cooling, 21°C and base setpoint value + dead zone are sent respectively (21°C + 2 K = 23°C)</p> <p>Same value in comfort operation mode during both heating and cooling operation, i.e.: Base setpoint value + half dead zone are transmitted to prevent occupants being inconvenienced. Example with Base setpoint value 21°C and dead zone of 2K: Mean value= 21°+1 K =22°C Although control takes place at 21°C or 23°C</p>
<i>Cyclical transmission of current setpoint value</i>	<p>not cyclical, only in the event of change</p> <p><i>Every 2 min.</i> <i>Every 3 min.</i> <i>Every 5 min.</i> <i>Every 10 min.</i> <i>Every 15 min.</i> <i>Every 20 min.</i> <i>Every 30 min.</i> <i>Every 45 min.</i> <i>Every 60 min.</i></p>	<p>How often should the currently valid setpoint value be sent?</p> <p>Only send in the event of a change.</p> <p>Cyclical transmission</p>
LIMITS		
<i>Maximum valid setpoint offset</i>	<p>+/- 1 K, +/- 2 K, +/- 3 K, +/- 4 K, +/- 5 K</p>	<p>Limits the possible setting range for the setpoint offset function.</p> <p>Applicable for the received values above object 1 (manual setpoint offset).</p>

Continuation:

Designation	Values	Description
<i>Minimum valid base setpoint value</i>	5°C, 6°C, 7°C, 8°C, 9°C, 10°C , 11°C, 12 °C, 13°C, 14°C, 15°C, 16°C 17°C, 18°C, 19 °C, 20 °C	If a base setpoint value received by object 0 is lower than the set value, it will be limited to this value.
<i>Maximum valid base setpoint value</i>	20 °C, 21°C, 22 °C 23°C, 24 °C, 25°C 27 °C, 30 °C, 32 °C	If a base setpoint value received by object 0 is higher than the set value, it will be limited to this value.

6.3.4.5 Cooling control

Table 19

Designation	Values	Description
<i>Setting the control parameters</i>	Via system type	Standard application
	<i>user-defined</i>	Professional use: Configure P/PI controller yourself
<i>System type</i>	Cooling surface	PI control with: Integrated time = 240 minutes Bandwidth = 5 K
	<i>Fan coil unit</i>	Integrated time = 180 minutes Bandwidth = 4 k
User-defined control parameter		
<i>Proportional band of the cooling control</i>	1 K, 1.5 K, 2 K, 2.5 K, 3 K 3.5 K, 4 K , 4.5 K 5 K, 5.5 K, 6 K 6.5 K, 7 K, 7.5 K 8 K, 8.5 K	Professional setting for adapting control response to the room. Large values cause finer changes to the actuating value with the same control deviation and more precise control than smaller values.
<i>Integrated time of the cooling control</i>	<i>pure P control</i> 15 min, 30 min, 45 min 60 min, 75 min, 90 min 105 min, 120 min, 135 min 150 min, 165 min, 180 min 195 min, 210 min, 4 h, 5 h, 10 h 15 h, 20 h, 25 h, 30 h, 35 h	See appendix temperature control Only for PI controller: The integrated time determines the reaction time of the control. It establishes the increase by which the actuating value from the controller is raised in addition to that from the P-term. The I-term remains active for as long as there is a control deviation. The I share is added to the P share.
<i>Send cooling actuating value</i>	With change of 1 % With change of 2 % With change of 3 % With change of 5 % With change of 7 % With change of 10 % With change of 15 %	After how much % change* in the actuating value is the new value to be sent. Small values increase control accuracy and also the bus load.
<i>Cyclical Send cooling actuating value</i>	not cyclical, only in the event of change Every 2 min., every 3 min. Every 5 min, every 10 min. Every 15 min, every 20 min. Every 30 min, every 45 min. Every 60 min.	How often is the current cooling actuating value to be sent (regardless of changes)?

Continuation:

Designation	Values	Description
<i>Changeover between heating and cooling</i>	<i>automatic</i>	HMG 6 T automatically switches to cooling mode when the actual temperature is above the setpoint value.
	<i>via object</i>	The cooling mode can only be activated on the bus via object 9 (1= cool). Cooling mode remains off for as long as this object is not set.
<i>Output of the cooling actuating value*</i>	<i>on separate object (object 8)</i>	For 4-pipe systems: The heating actuating value is sent to object 7 and the cooling actuating value to object 8.
	<i>Together with heating actuating value (object 7)</i>	For 2-pipe systems: The actuating value is always sent to object 7, independent of whether heating or cooling mode is active.

* Only when changeover between heating and cooling via object.

6.3.4.6 Cooling setpoint values

Table 20

Designation	Values	Description
<i>Dead zone between heating and cooling*</i>	0 K 1 K 2 K 3 K 4 K 5 K 6 K	Specifies the buffer zone between setpoint values in heating and cooling modes. The dead zone is expanded through hysteresis in switching (2 point) control. See glossary: Dead zone. 0 K: Only for 2-pipe systems, i.e. parameter: <i>switchover between heating and cooling = via object and output of cooling actuating value = together with heating actuating value.</i>
<i>Increase in standby mode (during cooling)</i>	0 K, 0.5 K, 1 K, 1.5 K 2 K, 2.5 K, 3 K 3.5 K, 4 K, 5 K	The standby temperature is increased in the cooling mode
<i>Increase in night mode (during cooling)</i>	3 K, 4 K, 5 K 6 K, 7 K, 8 K	See increase in standby mode
<i>Setpoint value for heat protection mode (during cooling)</i>	42 °C (does not represent heat protection) 29 °C, 30 °C, 31 °C 32 °C, 33 °C, 34 °C 35 °C	Heat protection represents the maximum permitted temperature for the controlled room. It performs the same function during cooling as the frost protection mode during heating, e.g. saves energy while prohibiting non-permitted temperatures.

* According to each type of control:

"+ Heating hysteresis" or

"+ Heating hysteresis + cooling hysteresis"

6.3.4.7 Operating mode

Table 21

Designation	Values	Description
<i>Operating mode after reset</i>	<i>Frost protection</i> <i>temperature reduction at night</i> Standby <i>Comfort</i>	Operating mode after start-up or reprogramming
<i>Type of presence sensor</i> <i>(to obj. 4)</i>	Presence detector <i>Presence buttons</i>	The presence sensor activates the comfort operating mode Comfort operation mode as long as the presence object is set. <ol style="list-style-type: none"> 1. If the operation mode object (object 3) is called up again after setting the presence object the new operating mode will be accepted and the state of the presence object ignored. 2. If the presence object is set during night / frost operation, it is reset after the configured comfort extension finishes (see below). 3. The presence object is not reported on the bus
<i>Comfort extension by presence keys in night mode*</i>	<i>none</i> <i>30 min.</i> <i>1 hour</i> <i>1.5 hours</i> 2 hours <i>2.5 hours</i> <i>3 hours</i> <i>3.5 hours</i>	Telegrams from presence button are not considered. Party switching: This allows the HMG 6 T to change via the presence object from night/frost mode to comfort mode again for a set length of time. The time limit is omitted if the device was previously in standby mode. Comfort operation is only cleared with the next manual or bus controlled change of operation mode.

Continuation:

Designation	Values	Description
<i>Cyclical transmission of current operating mode</i>	<p><i>not cyclical, only in the event of change</i></p> <p><i>Every 2 min, every 3 min.</i></p> <p><i>Every 5 min, every 10 min.</i></p> <p><i>Every 15 min, every 20 min.</i></p> <p><i>Every 30 min, every 45 min.</i></p> <p><i>Every 60 min.</i></p>	How often should the current operating mode be sent?

6.3.4.8 Channel characteristics

Table 22

Designation	Values	Description
<i>Channel processes actuating value for</i>	Heating	Only for heating and cooling mode and <i>Output of cooling actuating value = to separate object.</i> Channel responds to the heating actuating value
	Cooling	Channel responds to the cooling actuating value
	Heating or cooling	Only for heating and cooling mode and <i>Output of cooling actuating value = together with heating actuating value.</i> Channel responds to the actuating value independently of the parameter
<i>Time for one actuation cycle</i>	<i>2, 3, 5, 7, 10, 15, 20, 30 min</i>	For "continuous" actuating value. An actuation cycle consists of a switching-on and a switching-off process and forms a PWM period. Examples: - Actuating value = 20%, - Time = 10 min. means: switched on for 2 min. during the actuating cycle of 10 min. (i.e. 20% of actuating cycle) and switched off for 8 min. - Actuating value = 70%, time = 10 min. means: 7 min. on / 3 min. off. See appendix: PWM cycle
<i>Actuator direction of operation</i>	Standard: 1 = Open valve (Theben actuator)	Standard. Valve closed when de-energised.
	Inverted: 0 = Open valve	Special inverted valve types. Valve open when de-energised.
<i>Minimum actuating value</i>	0%, 5%, 10%, 20%, 30%	Lowest permissible actuating value

Continuation:

Designation	Values	Description
<i>Maximum actuating value</i>	50%, 60%, 70%, 80%, 90%, 100%	Highest permissible actuating value. A highest value of 90% extends the service life of thermal actuators. A highest value of 100% reduces the number of switching cycles
<i>Actuating value when value violates the min./max. actuating value</i>	0% and/or 100 % <i>Use set actuating values</i> 0 = 0%, otherwise use set actuating values < <i>Min. actuating value = 0 %</i> , otherwise scale.	Restriction when a room thermostat receives an actuating value that is less than the minimum actuating value: Actuate channel with 0% or 100% Restrict values to maximum and minimum actuating values. For example, maintaining a minimum actuating value of 10% can be practical for the correct base temperature of an underfloor heating. If the received actuating value is = 0, accept this value and close the valve. Other values are restricted as per the configured minimum and maximum actuating values. Actuating values below the minimum actuating values are interpreted as 0 %. Values above are scaled in proportion to the range between the min. actuating value and 100 %.
<i>Take channel H1 into account for highest actuating value</i>	<i>no</i> yes	Should the actuating value for channel 1 be used for determining the highest actuating value of all channels?
<i>Take channel H1 into account for pump control</i>	<i>no</i> yes	Should the supply pump be switched on in case of heat requirement in channel 1?

*Change since last transmission.

6.3.4.9 Channel H1- H6 monitoring

Central settings for monitoring the actuating value (heating actuator), actual value (heating controller) and outside temperature (emergency program).

Table 23

Designation	Values	Description
<i>Monitoring time</i>	<p>5 min. 10 min. 20 min. 30 min. 60 min.</p>	Start emergency program if the relevant data were not received within the configured time.
<i>Status of monitoring</i>	<p>Report only in the event of malfunction</p> <p>Always report</p>	<p>Do not send any telegrams during normal operation, only in the event of failure.</p> <p>Status will also be sent when there is no fault.</p>
<i>Send status cyclically</i>	<p>no yes</p>	Send status messages cyclically?
<i>Cycle time</i>	<p>Every 2 min, every 3 min. Every 5 min., every 10 min., every 15 min., every 20 min., every 30 min.</p>	At what interval should the status be sent?

6.3.4.10 HMG 6 T pump

Table 24

Designation	Values	Description
<i>Only switch on pump when at least</i>	<p><i>one input variable > 0%</i></p> <p><i>one valve is actuated (Open)</i></p>	<p>Additional function for devices manufactured as of October 2016. Strategy for pump control.</p> <p>Standard (as prior to October 2016). The pump is switched on as soon as the input variable of a channel is over 0%.</p> <p>As above, however, the pump will always be switched off when, due to the PWM cycle, all valves are closed.</p>
<i>Switch-off delay for pump</i>	<p><i>No switch-off delay</i></p> <p><i>2 min., 3 min., 5 min., 7 min., 10 min., 15 min., 20 min., 30 min.</i></p>	<p>The pump should: switch off immediately</p> <p>Continue running for a set length of time.</p>
<i>Send pump control cyclically</i>	No, only in the event of change <i>Cyclically and in the event of change</i>	How should the switch command for the pump to be sent?
<i>Send highest actuating value cyclically (If continuous actuating value used)</i>	No, only in the event of change <i>Cyclically and in the event of change</i>	do not send cyclically. On change (ON-OFF, OFF-ON) and send cyclically.
<i>Cycle time</i>	<i>Every 2 min, every 3 min. Every 5 min., every 10 min., every 15 min., every 20 min., every 30 min.</i>	At what interval should the switch telegram for the pump be sent?

7 Typical applications

These typical applications are designed to aid planning and are not to be considered an exhaustive list. It can be extended and updated as required.

7.1 Simple control with one HMG 6 T channel as heating actuator

Channel 1 is configured as a heating actuator and is controlled by a VARIA room thermostat. Presence and window status are sensed by a presence detector and a window contact. Summer mode is selected manually by means of a switch.

7.1.1 Devices:

- HMG 6 T (Order no. 4930240)
- VARIA 826 / 826 S KNX (Order no. 8269200, 8269210, 8269211)
- TA 2 (Order no. 4969202)
- Compact office EIB (Order no. 2019200)

7.1.2 Overview

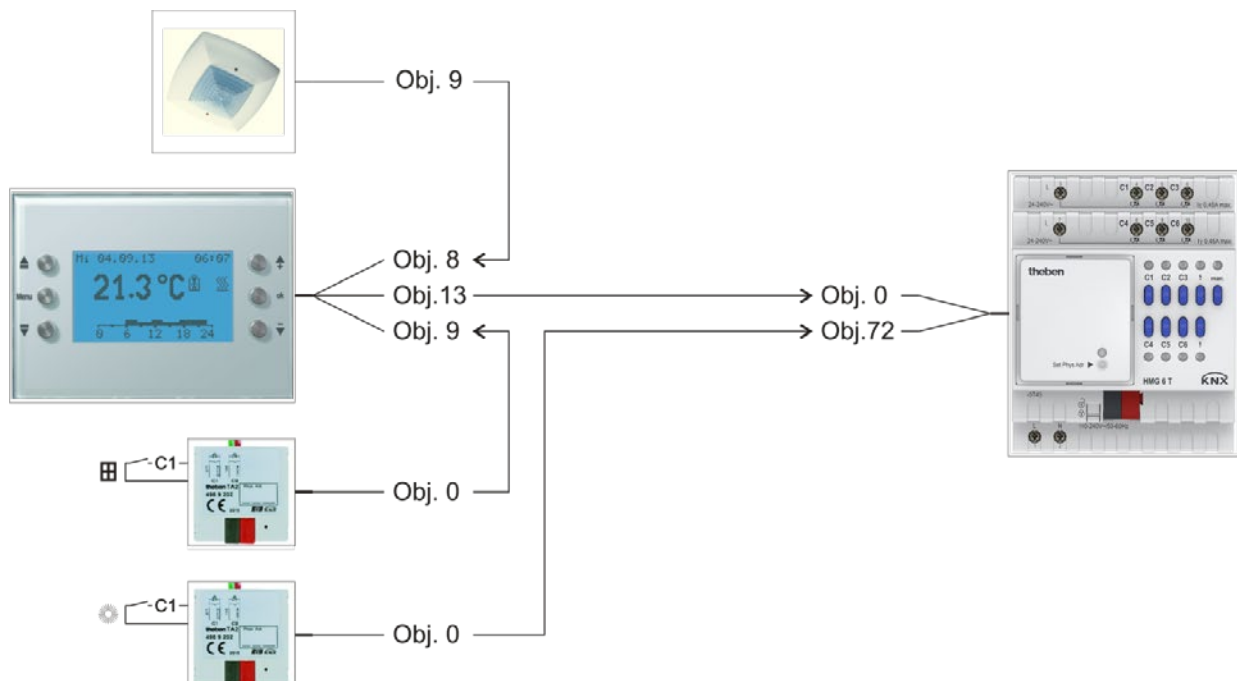

Figure 1

7.1.3 Objects and links

Table 25:

No.	Compact Office Object name	No.	Varia Object name	Comment
9	<i>Presence output</i>	8	<i>Input for presence signal</i>	Energy-saving function.

Table 26:

No.	TA 2 window contact  Object name	No.	Varia Object name	Comment
0	<i>Channel 1 switching</i>	9	<i>Input for window contact</i>	A window contact is connected to C1. On = Window is open Off = Window is closed. When the window is opened, the VARIA RTR changes to the frost protection operating mode.

Table 27:

No.	TA 2 summer mode  Object name	No.	HMG 6 T Object name	Comment
0	<i>Channel 1 switching</i>	72	<i>Summer mode ON/OFF</i>	A switch is connected to C1. On = Summer mode Off = Winter mode.

Table 28:

No.	Varia Object name	No.	HMG 6 T Object name	Comment
13	<i>Heating actuating value</i>	0	<i>Continuous actuating value</i>	Actuating value for the heating channel.

7.1.4 Important parameter settings

Standard or customer-defined parameter settings apply for unlisted parameters.

Table 29: HMG 6 T

Parameter page	Parameter	Setting
<i>General</i>	<i>Type of basic module</i>	<i>HMG 6 T</i>
<i>HMG 6 T Channel H1: Configuration options</i>	<i>Channel function</i>	<i>Heating actuator</i>
	<i>Type of actuating value</i>	<i>Continuous</i>
	<i>Include in summer mode</i>	<i>yes</i>

Table 30: VARIA

Parameter page	Parameter	Setting
<i>RTR setting</i>	<i>CONTROL</i>	<i>Heating control only</i>
	<i>Objects for determining the operating mode</i>	<i>New: operating mode, presence, window status.</i>
	<i>Type of presence sensor</i>	<i>Presence detector</i>
<i>Heating control</i>	<i>Number of heating stages</i>	<i>Only one heating stage</i>
	<i>Type of control</i>	<i>Continuous control</i>

Table 31: Compact Office EIB

Parameter page	Parameter	Setting
<i>General data</i>	<i>select</i>	<i>Master in single unit operation</i>
	<i>Presence output</i>	<i>active</i>
	<i>Normal or test operation mode</i>	<i>Standard operation</i>
<i>Presence output</i>	<i>Presence switch-on delay</i>	<i>5 minutes</i>
	<i>Behaviour at start of presence</i>	<i>Send ON telegram</i>
	<i>Behaviour at end of presence</i>	<i>Send OFF telegram</i>

Table 32: TA 2 for window contact.

Parameter page	Parameter	Setting
<i>Channel 1</i>	<i>Channel function</i>	<i>Switch/push button</i>
	<i>Debounce time</i>	<i>100 ms</i>
	<i>Object type</i>	<i>Switching (1-bit)</i>
	<i>Response to rising edge</i>	<i>ON (OFF*)</i>
	<i>Response to falling edge</i>	<i>OFF (ON*)</i>
	<i>Response after restoration of the bus supply</i>	<i>update</i>

* Depending on type of window contact.

The details in brackets refer to the following case:

Window closed → contact closed

Table 33: TA 2 for summer mode.

Parameter page	Parameter	Setting
<i>Channel 1</i>	<i>Channel function</i>	<i>Switch/push button</i>
	<i>Debounce time</i>	<i>100 ms</i>
	<i>Object type</i>	<i>Switching (1-bit)</i>
	<i>Response to rising edge</i>	<i>ON</i>
	<i>Response to falling edge</i>	<i>OFF</i>
	<i>Send telegram cyclically</i>	<i>yes</i>
	<i>Cycle time</i>	<i>60 minutes</i>
	<i>Response after restoration of the bus supply</i>	<i>update</i>

7.2 School location : HMG 6 T as heating controller with automatic summer mode.

The HMG 6 T basic module controls the heating in 6 classrooms.

The room temperature is determined by an Amun 716* CO₂ sensor.

The HVAC operating mode is controlled centrally by a timer.

If a window is opened, control changes to the frost protection mode.

The comfort mode is activated by a presence button.

To save energy costs, control should change over to the summer mode automatically when the weather is mild.

This is achieved with the aid of a Meteodata 139 weather data receiver.

7.2.1 Devices:

- HMG 6 T (Order no. 4930240)
- Amun 716 KNX (Order no. 7169200)
- TA 2 (Order no. 4969202)
- TR 648 top2 RC KNX (Order no. 6489212)
- Meteodata 139 KNX (Order no. 1399200)

* Additional functions of the CO₂ sensor (ventilation control etc.) are described in detail in the Amun 716 KNX manual and are not discussed here.

7.2.2 Overview

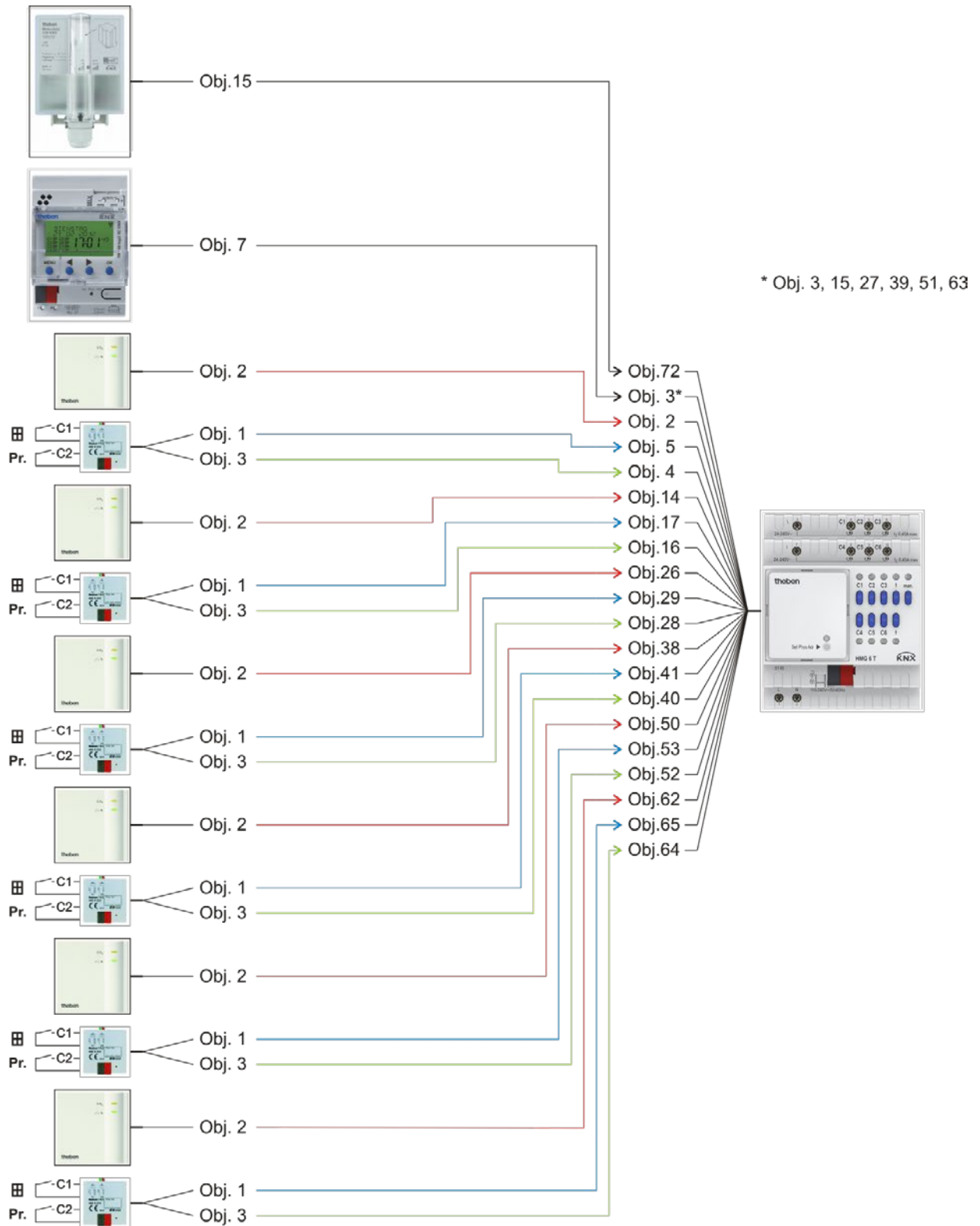

Figure 2

7.2.3 Objects and links

Table 34:

No.	Meteodata 139 Object name	No.	HMG 6 T Object name	Comment
15	<i>Summer mode heating message</i>	72	<i>Summer mode ON/OFF</i>	The Meteodata 139 activates the summer mode if all conditions are met.

Table 35:

No.	TR 648 top 2 RC KNX Object name	No.	HMG 6 T Object name	Comment
7	<i>HVAC switching channel</i>	3 15 27 39 51 63	<i>Operating mode preset Channel H1</i>	Central function for specifying the operating mode in all rooms. All objects share a common group address.

Table 36: Rooms 1-6.

No.	6x Amun 716 Object name	No.	HMG 6 T Object name	Comment
2	<i>Temperature value</i>	2	<i>Actual value</i>	Current room temperature in room 1
2	<i>Temperature value</i>	14	<i>Actual value</i>	Current room temperature in room 2
2	<i>Temperature value</i>	26	<i>Actual value</i>	Current room temperature in room 3
2	<i>Temperature value</i>	38	<i>Actual value</i>	Current room temperature in room 4
2	<i>Temperature value</i>	50	<i>Actual value</i>	Current room temperature in room 5
2	<i>Temperature value</i>	62	<i>Actual value</i>	Current room temperature in room 6

Table 37: 6x TA 2 , rooms 1-6.

No.	TA 2	No.	HMG 6 T	Comment
	Object name		Object name	
1	<i>Channel 1 switching</i>	5	<i>Window position</i>	Window position and presence status for room 1
3	<i>Channel 2 switching</i>	4	<i>Presence</i>	
1	<i>Channel 1 switching</i>	17	<i>Window position</i>	Window position and presence status for room 2
3	<i>Channel 2 switching</i>	16	<i>Presence</i>	
1	<i>Channel 1 switching</i>	29	<i>Window position</i>	Window position and presence status for room 3
3	<i>Channel 2 switching</i>	28	<i>Presence</i>	
1	<i>Channel 1 switching</i>	41	<i>Window position</i>	Window position and presence status for room 4
3	<i>Channel 2 switching</i>	40	<i>Presence</i>	
1	<i>Channel 1 switching</i>	53	<i>Window position</i>	Window position and presence status for room 5
3	<i>Channel 2 switching</i>	52	<i>Presence</i>	
1	<i>Channel 1 switching</i>	65	<i>Window position</i>	Window position and presence status for room 6
3	<i>Channel 2 switching</i>	64	<i>Presence</i>	

7.2.4 Important parameter settings

Standard or customer-defined parameter settings apply for unlisted parameters.

Table 38: HMG 6 T

Parameter page	Parameter	Setting
<i>General</i>	<i>Type of basic module</i>	<i>HMG 6 T</i>
<i>HMG 6 T Channel H1-H6: Configuration options</i>	<i>Channel function</i>	<i>Heating controller</i>
	<i>Include in summer mode</i>	<i>yes</i>
<i>Settings</i>	<i>CONTROL</i>	<i>Standard</i>
<i>select</i>	<i>Type of presence sensor</i>	<i>Presence buttons</i>

Table 39: Meteodata 139 KNX

Parameter page	Parameter	Setting
<i>Summer mode</i>	<i>These parameter settings depend on the local circumstances and the particular user requirements.</i>	

Table 40: TR 648 top 2 RC KNX

Parameter page	Parameter	Setting
<i>Switching channel C1</i>	<i>Telegram type C1.1</i>	<i>HVAC operating mode</i>

Table 41: 6x Amun 716

Parameter page	Parameter	Setting
<i>Measured values</i>	<i>Transmit temperature in the event of change of</i>	<i>0.2°C</i>

Table 42: 6x TA 2

Parameter page	Parameter	Setting
<i>Channel 1</i>	<i>Channel function</i>	<i>Switch/push button</i>
	<i>Debounce time</i>	<i>100 ms</i>
	<i>Object type</i>	<i>Switching (1-bit)</i>
	<i>Response to rising edge</i>	<i>ON (OFF*)</i>
	<i>Response to falling edge</i>	<i>OFF (ON*)</i>
	<i>Response after restoration of the bus supply</i>	<i>update</i>
<i>Channel 2</i>	<i>Channel function</i>	<i>Switch/push button</i>
	<i>Debounce time</i>	<i>100 ms</i>
	<i>Object type</i>	<i>Switching (1-bit)</i>
	<i>Response to rising edge</i>	<i>ON</i>
	<i>Response to falling edge</i>	<i>none</i>
	<i>Response after restoration of the bus supply</i>	<i>none</i>

* Depending on type of window contact. The details in brackets refer to the following case: Window closed → contact closed.

8 APPENDIX

8.1 Determining the current operating mode

The current setpoint value can be adjusted to the relevant requirements via the choice of operation mode.

The operating mode can be specified by objects 3..5.

The current operating mode can be specified as follows:

Table 43

Operating mode preset Object 3	Presence Object 4	Window status Object 5	Current operating mode (object 6)
any	any	1	frost / heat protection
any	1	0	Comfort
Comfort	0	0	Comfort
Standby	0	0	Standby
Night	0	0	Night
frost / heat protection	0	0	frost / heat protection

8.1.1 Determining the setpoint value

8.1.1.1 Calculating the setpoint value in heating operation

See also: Base setpoint value and current setpoint value

Table 44: Current setpoint value during heating

select	Current setpoint value
Comfort	Base setpoint value +/- setpoint offset
Standby	Base setpoint value +/- setpoint adjustment – reduction in standby mode
Night	Base setpoint value +/- setpoint adjustment – reduction in standby mode
Frost / heat protection	configured setpoint value for frost protection mode

Example:

Heating in comfort operating mode.

Parameter page	Parameter	Setting
<i>Setpoint values</i>	<i>Base setpoint value after loading the application</i>	21 °C
	<i>Reduction in standby mode (during heating)</i>	2 K
	<i>Maximum valid setpoint offset</i>	+/- 2 K

The setpoint value was previously increased by 1 K via object 1.

Calculation:

$$\begin{aligned}
 \text{Current setpoint value} &= \text{base setpoint value} + \text{manual setpoint offset} \\
 &= 21^{\circ}\text{C} + 1\text{K} \\
 &= 22^{\circ}\text{C}
 \end{aligned}$$

If operation is switched to standby mode, the current setpoint value is calculated as follows:

$$\begin{aligned}
 \text{Current setpoint} &= \text{base setpoint} + \text{setpoint offset} - \text{reduction in standby mode} \\
 &= 21^{\circ}\text{C} + 1\text{K} - 2\text{K} \\
 &= 20^{\circ}\text{C}
 \end{aligned}$$

8.1.1.2 Calculating the setpoint value in the cooling mode

Table 45: current setpoint value during cooling

select	Current setpoint value
Comfort	Base setpoint value + Setpoint offset + dead zone
Standby	Base setpoint value + setpoint offset + dead zone + increase in standby mode
Night	Base setpoint value + setpoint offset + dead zone + increase in night mode
Frost / heat protection	configured setpoint value for heat protection mode

Example:

Cooling in comfort operating mode.

The room temperature is too high and the HMG 6 T has switched to the cooling mode

Parameter page	Parameter	Setting
<i>Setpoint values</i>	<i>Base setpoint value after loading the application</i>	21 °C
	<i>Maximum valid setpoint offset</i>	+/- 2 K
<i>Cooling setpoint values</i>	<i>Dead zone between heating and cooling</i>	2 K
	<i>Increase in standby mode (during cooling)</i>	2 K

The setpoint value was previously lowered by 1 K via object 1.

Calculation:

$$\begin{aligned}
 \text{Current setpoint value} &= \text{base setpoint value} + \text{manual setpoint offset} + \text{dead zone} \\
 &= 21^{\circ}\text{C} - 1\text{K} + 2\text{K} \\
 &= 22^{\circ}\text{C}
 \end{aligned}$$

Changing to standby mode causes a further increase in the setpoint value (energy saving) and gives rise to the following setpoint value.

$$\begin{aligned}
 \text{Setpoint value} &= \text{base setpoint value} + \text{setpoint offset} + \text{dead zone} + \text{increase in standby mode} \\
 &= 21^{\circ}\text{C} - 1\text{K} + 2\text{K} + 2\text{K} \\
 &= 24^{\circ}\text{C}
 \end{aligned}$$

8.2 Setpoint offset

The current setpoint value can be adjusted in the HMG 6 T via object 1 *manual setpoint offset*. In this case, the setpoint value is changed by sending the desired offset to object 1. This involves the differential (may be preceded by a minus sign) being sent in EIS5 format to object 1.

The differential between the setpoint offset and Basissollwert is sent by object 10 at each change (e.g. -1.00).

The offset limits are set on the *Setpoint values* parameter page via the *Maximum valid setpoint offset* parameter.

The offset is always in relation to the Basissollwert and not the current setpoint value.

Example Base setpoint value of 21°C:

If a value of 2.00 is received by object 1, the new setpoint value was calculated as follows:

$$21^{\circ}\text{C} + 2.00\text{K} = 23.00^{\circ}\text{C}.$$

To then bring the setpoint value to 22°C, the differential to the programmed base setpoint value (here 21°C) is resent, in this case 1.00 K ($21^{\circ}\text{C} + 1.00\text{K} = 22^{\circ}\text{C}$)

8.3 Base setpoint value and current setpoint value

The **base setpoint value** is the standard temperature for the comfort mode and the reference temperature for reduction in standby and night modes.

The programmed basic setpoint value (see base setpoint value after downloading the application) is stored in object 0 and can be changed at any time via the bus by sending a new value to object 0 (EIS5).

The **current setpoint value** is the value that actually is used for control. It is the result of all the reductions or increases associated with the operating mode and implemented by the control function.

Example:

At a base setpoint value of 22°C and a reduction in night mode of 4K, the current setpoint value (in night mode) is: 22°C - 4K = 18°C. During the day (in comfort mode), the current setpoint value is 22°C (provided that the cooling mode is not active).

The formation of the current setpoint value due to the basic setpoint value can be observed in the block diagram on the next page:

The base setpoint value, specified via object 0, is on the left.

The current setpoint value is on the right, i.e. the value upon which the room temperature is effectively controlled.

As you can see in the block diagram, the current setpoint value depends on the operating mode and the control function. selected.

The base setpoint value limits prevent an incorrect base setpoint value from being specified to object 0. These are the following parameters:

- Minimum valid base setpoint value
- Maximum valid base setpoint value

If because of a setpoint offset the setpoint value is outside the programmed values for frost and heat protection, it is restricted to these values by the safety limits.

See also: Setpoint value calculation.

8.4 Short-circuit and overcurrent shutdown

The channel blocks H1-H3 and H4-H6 are always protected by a reversible safety device whose state is monitored.

After the safety device trips, all 3 channels are shut off for 20 seconds, the LED indicating a malfunction flashes at a frequency of 5 Hz and the corresponding "Overcurrent / short circuit" object is set.

Following this, all 3 channels are switched on in succession for testing.

If the safety device trips again, the associated channel is switched off, the channel LED flashes at a frequency of 5 Hz, the "Overcurrent / short circuit" object for the affected group remains set (obj. 73 and 74)

Operation of the other channels remains unaffected.

If the safety device does not trip again when tested, it is assumed that an overload occurred. The LED indicating a malfunction is illuminated continuously, the "Overcurrent / short circuit" object for the associated group is reset (obj. M3 and 74).

Operation of all 3 channels remains unaffected.

If no further malfunction occurs during the next 24 hours in this condition, the LED indicating a malfunction goes out.

If 1-4 malfunctions occur again during the 24 hours following the initial overload, the LED remains on 24 hours again.

If more than 5 malfunctions occur during the 24 hours following the initial overload, all 3 channels are switched off, the LEDs for the channels flash at a frequency of 2 Hz, the LED indicating a malfunction is illuminated continuously, the "Overcurrent / short circuit" object is set.

8.5 Load distribution, connection of devices

By combining 3 channels on one safety device (see above), it is also possible to distribute loads asymmetrically over the 3 channels as long as the total current of 0.45 A is not exceeded.

Example:

$C1 = 0.025A$,

$C2 = 0.025A$,

$C3 = 0.4 A$

is permissible

Brief inrush current levels of up to 0.75 A per group are permissible (max. 10 s).

Depending on the ambient temperature and air circulation at the installation location, the safety device may trip in the event of longer-lasting current loads between 0.45 A and 0.75 A per group.

8.6 Conversion of percentages to hexadecimal and decimal values

Table 46

Percentage value	0%	10%	20%	30%	40%	50%	60%	70%	80%	90%	100%
Hexadecimal	00	1a	33	4D	66	80	99	B3	CC	E6	FF
Decimal	00	26	51	77	102	128	153	179	204	230	255

All values from 00 to FF hex. (0 to 255 dec.) are valid.