

Application Switching Basic 4720/1.0

Function overview

This application provides you with the following functions:

- Behaviour on bus voltage failure 2
- Behaviour on bus voltage recovery 2
- Behaviour after ETS download 2
- Status response 3
- Switching functions 3
 - Switching 3
 - Central switching function 4
- Time function 4
 - Staircase lighting function 4
- Higher priority functions 6
 - Logic operations 6
 - AND 6
 - OR 7

Control

When the application is loaded, the following functions can be implemented and controlled via the bus:

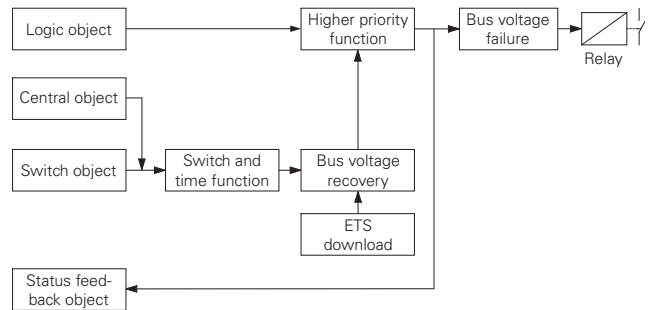

Priorities

With regard to the switching behaviour of the actuator, each function has a certain priority. The weighting of the functions can be taken from the following table:

Priority	Function
Highest priority	Relay state after bus voltage failure
	Higher priority function "Logic operation"
	Relay state after bus voltage recovery, ETS download
Lowest priority	Switching function, time function, central switching function

- i** Many parameters and their settings are dependent on the settings you have already made for other parameters. This means that some parameters will appear or disappear and the values available for selection will change according to settings you have already made. These dependencies have not been shown in the table for reasons of clarity. All settings are always shown.
- i** Configurable times are set via the base and factor parameters. The actual time is given by the multiplication of the two values. Example:
Base = 1 second, Factor = 3
Actual time = 3 seconds
- i** The **bold** values in a table are the values set during factory configuration.

Behavior on bus voltage failure

Behavior on bus voltage failure

When the bus voltage drops below 18 V, the relay can adopt a parameterised state. The relay can either be closed, opened or remain in the position it occupied prior to the failure. At the same time, the current switching position of the relay is stored in the device. Only the actual relay state ("1" for closed; "0" for opened) at the time of the voltage failure is saved and not any active staircase timer. No further status response telegrams are sent. This function has the highest priority.

Parameters

Channel X: Logic & General	
Parameter	Setting
Relay state after bus voltage failure	no change
	opened
	closed

Behavior on bus voltage recovery

On bus voltage recovery, the relay can adopt a parameterised state. The following options are available for selection:

- „opened“ or „closed“
In the settings "opened" or "closed", the relay contact is opened or closed.
Staircase lighting functions: If the setting is „closed“ the staircase lighting function starts.
- „no change“
In the setting "no change", the relay remains in the current state. Any manual operation that occurs in the meantime is retained. The device does not know the status of the channel at this point and therefore no status signal can take place. The status is only available following a switching action of the channel.
- „as for bus voltage failure“
In the setting "as for bus voltage failure", the relay adopts the state which was stored in the device on bus voltage failure. Any manual operations that occur are overwritten. There are no stored states once the application has been downloaded. This means that the output is opened.

Before triggering the relay, a check is made to determine whether there is sufficient energy to operate the relay. If there is sufficient energy, the relay immediately switches to the parameterised state. Otherwise there is a delay until sufficient energy is available.

i Relay states that are caused by functions with a higher priority (higher priority function) take precedence over the behaviour after bus voltage recovery.
Example: OR logic operation with parameterised „Value of logic object after bus voltage recovery“ = „1“ takes priority and switches the output.

Status response

Each channel can deliver a status response, depending on the parameter settings. An exception is made in the setting "no change": since the current status cannot be reliably determined, no status telegram is sent.

Parameters

Channel X: Logic & General	
Parameters	Settings
Relay state after bus voltage recovery	no change
	as for bus voltage failure
	opened
	closed

Behaviour after ETS download

The relay remains in the state it occupied prior to the download. Any manual operation that occurs in the meantime is not overwritten.

The device does not know the status of the channel at this point and therefore no status signal can take place. The status is only available following a switching action of the channel.

i After an ETS download the relay state can be determined by a function of a higher priority (logic operation). Example: OR logic operation with parameterised "Value of logic object after bus voltage recovery = 1" and a telegram on the „Switch object“ closes the relay.

Status response

The status of the output is sent via its own communication object. This means that the status of the relay is available as a telegram on the bus after each switching process. The value of the "Status feedback object" always conveys the current status of the relay. When the relay is closed, the value is "1" while the value is "0" when the relay is opened.

i After bus voltage recovery and the parameter setting "Relay state after bus voltage recovery = no change": The device does not know the status of the channel at this point and therefore no status signal can take place. The status is only available following a switching action of the channel.

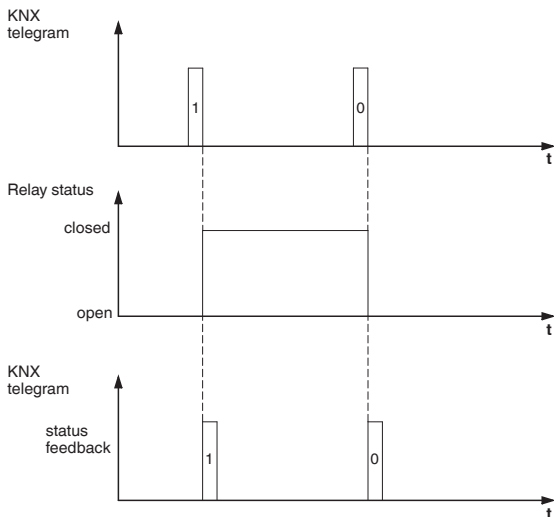

Status feedback

Communication objects

The following communication objects can be selected:
(Per channel)

Function	Object name	type	Prio	Flags	Behaviour
Channel X	Status feedback object	1 bit	Low	CRT	Transmit

Switching functions

Switching

Binary bus telegrams (EIS1 telegrams, 1 bit) are received via the "Switch object" and converted into switching states (relay open/relay closed). The application changes the value of the "Switch object" during operation. Reading out the "Switch object" via the bus does not convey the status of the relay. The status should always be read out via the "Status feedback object".

The switching behaviour of the normal switch function can be modified by activating functions with a higher priority (see 'Higher priority functions').

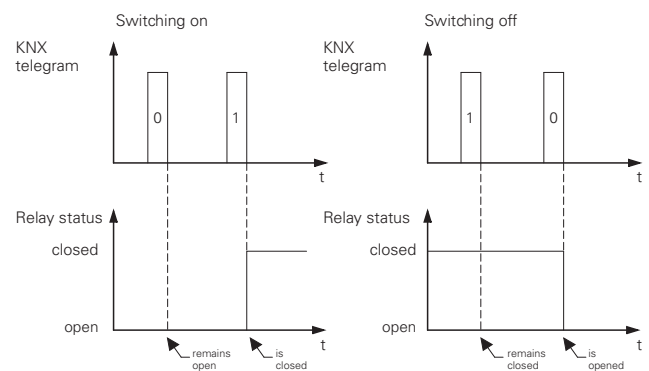

Switching

Before triggering the relay, a check is made to determine whether there is sufficient energy to operate the relay. If there is sufficient energy, the relay immediately switches to the parameterised state. Otherwise there is a delay until sufficient energy is available.

The fixed relay positions (open, closed) within the other functions are triggered directly.

Communication objects

The following communication objects can be selected:
(Per channel)

Function	Object name	Type	Prio	Flags	Behaviour
Channel X	Switch object	1 bit	Low	CW	Receive

Time function

Central function

The central function has its own communication object (central object). It can be set for each channel of the actuator whether and how the channel should react to the central object.

Using the parameters, you can set whether only the state "1" or "0" or both states of the central object for the channel should be evaluated.

The central function has a low priority. Telegrams from the central switch objects activate the set switching/ staircase lighting functions and higher priority functions in the same way as telegrams from the corresponding switch object.

The last telegram from the individual switch object or the central object always activates the functions that have been set for the channel.

Communication objects

The following communication objects can be selected:
 (Common for all channels)

Function	Object name	Type	Prio	Flags	Behaviour
Central function	Central object	1 bit	Low	CW	Receive

Parameters

Central function	
Parameter	Setting
Channel X	OFF at 0 or 1
	ON at 0 or 1
	ON at 0 / OFF at 1
	OFF at 0 / ON at 1
	OFF at 0 / no reaction at 1
	ON at 0 / no reaction at 1
	no reaction at 0 / OFF at 1
	no reaction at 0 / ON at 1
	no reaction at 0 or 1

Time function

Staircase lighting function (staircase timer)

In the staircase lighting function, once the device has been switched on via the "Switch object", it switches itself off automatically after an adjustable period.

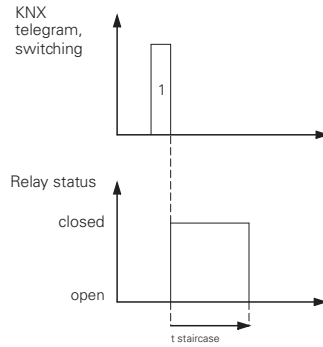

Staircase lighting function

The period ($t_{\text{staircase}}$) is calculated by multiplying a base value by a factor.

The settings "retriggerable" or "not retriggerable" define whether the staircase timer is restarted by means of a further "1" telegram. If the staircase lighting function is "retriggerable", the period can be extended via the bus.

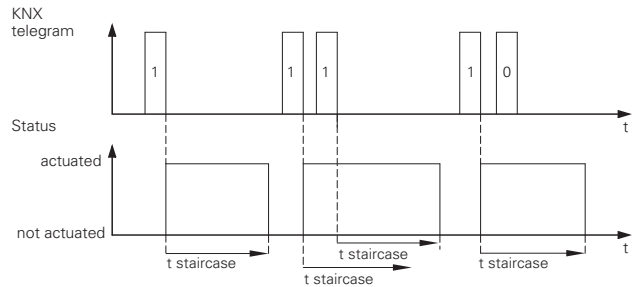

Retriggerable staircase lighting function without manual OFF function

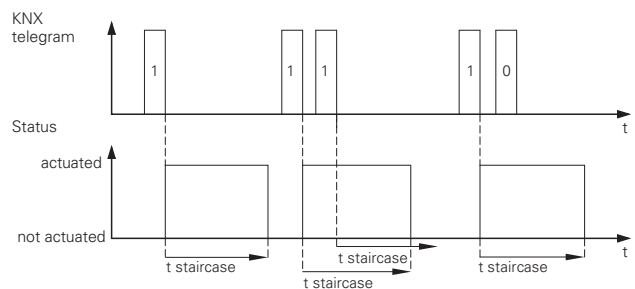

Non-retriggerable staircase lighting function without manual OFF function

For the staircase lighting function, you can use the parameter "with / without manual OFF function" to set whether the timer is switched off prematurely after a "0" telegram is received or whether the "0" telegram is ignored and the staircase timer continues to run.

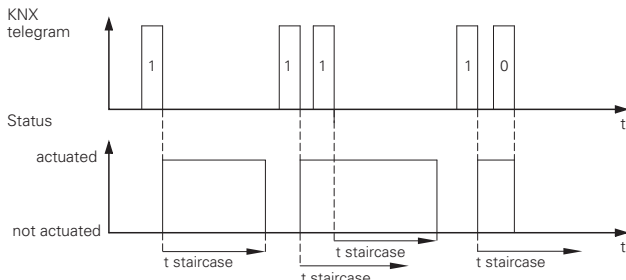

Retriggerable staircase lighting function with manual OFF function

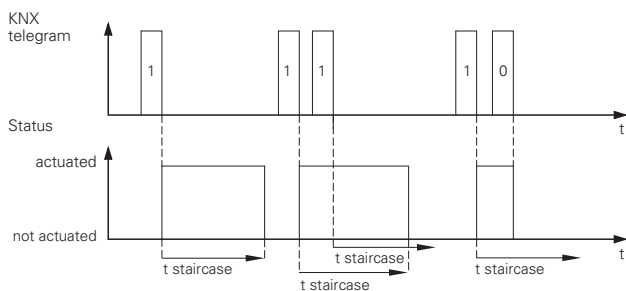

Non-retriggerable staircase lighting function with manual OFF function

The staircase lighting function can indicate that the end of the staircase timer is imminent by causing the luminaire to flicker. It is possible to select between one and three warnings. It is possible to set the time ($t_{warning}$) when the warnings should start before the staircase timer has elapsed. The length of the interruptions (t_l) and the interval between two warnings (t_{int}) can also be set.

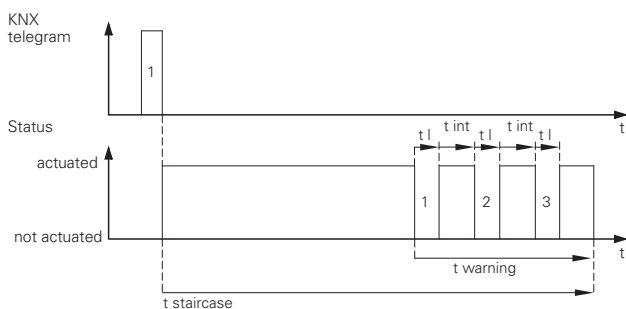

Staircase timer with prewarning

i In the case of staircase lighting functions with a manual OFF function and active prewarning, the staircase lighting function with prewarning is immediately deactivated when an OFF telegram is received.

If the output of the actuator is brought into a new switching position by a function with a higher priority while the staircase timer is active, the relay is immediately switched to this position. The last switching telegram is stored and the staircase timers continue to run.

i Switching functions and staircase lighting functions cancel each other out i.e. they cannot be active at the same time. If the staircase lighting function is parameterised, the channel only operates as a staircase timer. If the staircase lighting function is not set, the switching function is automatically active.

Communication objects

The following communication objects can be selected:
(Per channel)

Function	Object name	Type	Prio	Flags	Behaviour
Channel X	Switch object	1 bit	Low	CW	Receive

Parameters

Channel X: Staircase timer	
Parameter	Setting
Staircase lighting function	switched on switched off

Channel X: Staircase timer	
Parameter	Setting
Factor for staircase timer (1-255)	85 adjustable in single steps
Base for staircase timer	100 ms 1 s 1 min 1 h
Staircase time is	not retriggerable retriggerable
Staircase timer	with manual OFF without manual OFF
Warning at end of staircase time	OFF ON
Number of warnings	1 2 3
Warning time (1-255), factor * 1 s	30 adjustable in single steps
Time for interruptions (1-20) factor * 100 ms	5 adjustable in single steps
Time between warnings (1-255) factor * 1 s	5 adjustable in single steps

Higher priority functions

Higher priority functions

With regard to the switching behaviour of the actuator, the higher priority functions take precedence over the switching function and time functions. If a higher priority function is active, changes to the switch object no longer affect the relay output. The status of the relay remains in the position which was preselected by the higher priority function. Higher priority functions are carried out without a delay i.e. time functions are not taken into account when switched to a higher priority state.

In this application the higher priority function „logic operation“ is available. Each channel has an object for the logic operation (logic object).

Logic operations

With this functionality, the "Switch object" can be logically linked with the "Logic object". An AND or OR logic operation can be set. A parameter defines which value is preassigned to the logic object after bus voltage recovery.

For example, if the OR logic object is preset to "1" after bus voltage recovery, the output remains switched on until a "0" telegram has been received at the "Logic object". Any parameterised reaction after bus voltage recovery is only adopted once the logic operation has finished.

The logic function has a high priority. The actuator will thus always be set according to the logic result of the higher priority function and not the status of functions with a lower priority.

AND logic operation

While the "Logic object" has the value "0", switching can be carried out as usual via the address of the "Switch object". Any set staircase lighting functions are still valid. Switching off via the "Logic object" takes place immediately.

Logic object	Switch object	Result
0	0	0
0	1	0
1	0	0
1	1	1

Example:

A closing lock-out can be implemented with an AND logic operation. This means that it is not possible to switch on the output via the "Switch object" while the value of the "Logic object" remains set to "0". If the value of the "Switch object" is set to "1", the output is switched on automatically following a change in the value of the logic object from "0" to "1".

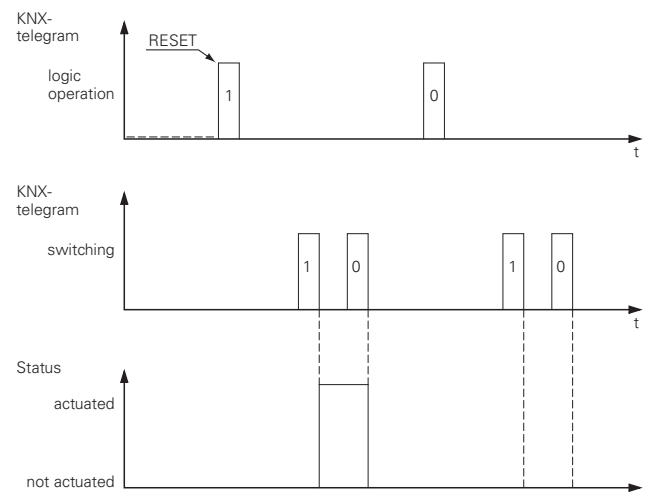

AND logic operation; Value of the logic object after bus voltage recovery: 1

The logic object is preassigned the value "1" after a RESET. Switching can therefore be carried out as usual via the switch object. The closing lock-out is only active after the receipt of a "0" telegram via the logic object.

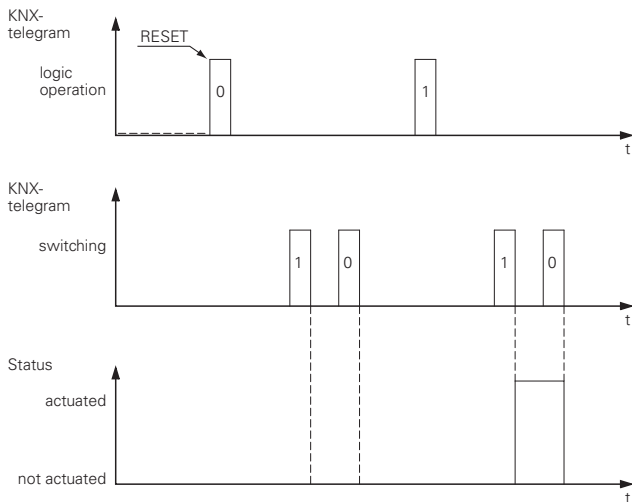

AND logic operation; Value of the logic object after bus voltage recovery: 0

The parameter setting causes the "Logic object" to be set to the value "0". After a RESET, the actuator will not switch the output, until a "1" telegram has been received at the "Logic object".

Communication objects

The following communication objects can be selected:
(Per channel)

Function	Object name	Type	Prio	Flags	Behaviour
Channel X	Switch object	1 bit	Low	CW	Receive
Channel X	Logic object	1 bit	Low	CW	Receive

Parameters

Channel X: Logic & General	
Parameter	Setting
Type of logic operation	OR AND
Value of logic object after bus voltage recovery	1 0

OR logic operation

While the "Logic object" has the value "0", switching can be carried out as usual via the address of the "Switch object". Any set staircase lighting functions are still valid. Switching on via the "Logic object" takes place immediately.

Logic object	Switch object	Result
0	0	0
0	1	1
1	0	1
1	1	1

Example:

An opening lock-out or central ON function (e.g. lighting for cleaning buildings) can be implemented with an OR logic operation. If the value of the "Switch object" is also set locally to "1", the relay remains closed when the opening lock-out is removed (value of the logic object changes from "1" to "0").

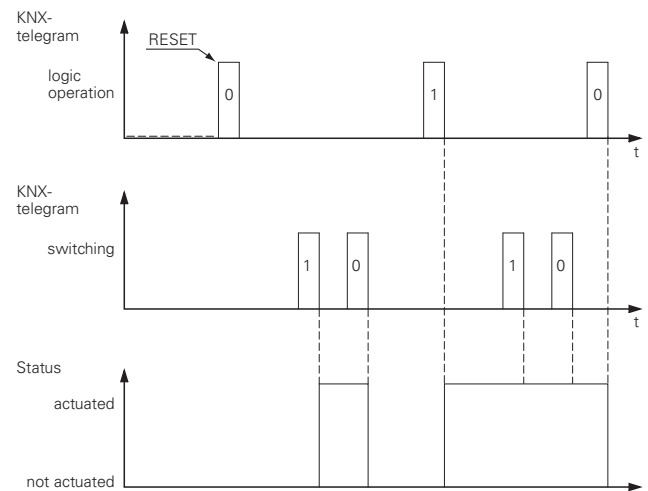

OR logic operation; Value of logic object after bus voltage recovery: 0

The relay can only be opened via the "Switch object" once a "0" telegram has been received via the "Logic object".

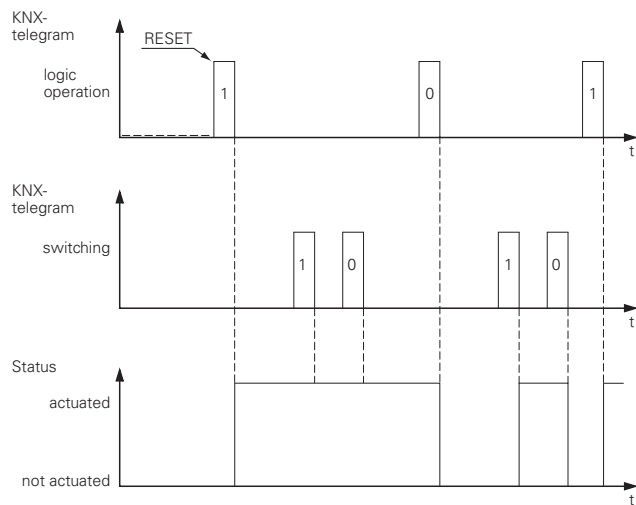

OR logic operation; Value of logic object after bus voltage recovery: 1

The logic object is preassigned the value "1" after a RESET. The actuator will immediately switch on the output. The OR logic function is only reset by a "0" telegram at the logic object.

Communication objects

The following communication objects can be selected:
 (Per channel)

Function	Object name	Type	Prio	Flags	Behaviour
Channel X	Switch object	1 bit	Low	CW	Receive
Channel X	Logic object	1 bit	Low	CW	Receive

Parameters

Channel X: Logic & General	
Parameter	Setting
Type of logic operation	OR AND
Value of logic object after bus voltage recovery	1 0

Schneider Electric Industries SAS

If you have technical questions, please contact the Customer Care Center in your country.

www.schneider-electric.com => "Select your country"