



enertex bayern gmbh
simulation entwicklung consulting

Manual and Configuration

KNX Smartmeter 85A (RT)



Advice

The contents of this document may not be wholly or partially, reproduced, transferred, distributed or stored in any form without prior written approval by Enertex® Bayern GmbH.

Enertex® is a registered trademark of Enertex® Bayern GmbH. Other product- and company names mentioned herein can be names of trademark or registered trademarks of their respective owners.

This manual may be changed without notifications or notice and makes no claim to completeness or accuracy.

Contents

Notes	3
Function	4
Technical specifications	4
Assembly	7
<i>Connection diagram</i>	7
<i>Assembly of the current sensors</i>	8
Commissioning	9
ETS-Application	10
<i>Specification</i>	10
<i>Data base file</i>	10
<i>Examples of settings</i>	10
Example 1:	
Visualization of energy consumption.....	10
Example 2:	
Bidirectional Counter for Photovoltaics.....	16
<i>Measurement quantities</i>	23
<i>General Function Concepts</i>	25
Cyclical transmitting.....	25
Transmit at Change.....	25
Bidirectional Counter.....	26
Intermediate Counter.....	27
Tariff Costs Counter.....	27
Preset of a Counter.....	28
Message of limit values.....	28
Recording on the SD card.....	29
Adjusting the real-time clock without bus access.....	31
<i>Parameter</i>	31
General.....	31
Measurement.....	33
Energy counter / Tariff cost counter.....	41
Tariff.....	48
<i>Group Objects</i>	51
Firmware update	69
Revision history	70

Notes

- Installation and assembly of electrical equipment must be carried out by qualified electricians.
- When connecting KNX/EIB interfaces specialist skills are required.
- Ignoring the instructions can damage the device, as well a fire or other hazards can arise.
- These instructions are part of the product and must be left with the end user.
- The manufacturer is not liable for costs or damages incurred by the user or third parties through the use of the device, misuse or malfunction of the connection, malfunction of the device or user equipment.
- Opening the housing, other unauthorized alterations and or modifications to the device will invalidate the warranty!
- Only the current sensors, which are included, may be connected to the current sensor inputs.
- The manufacturer is not liable for improper use.

Function

The KNX Smartmeter is a bidirectional counter for measuring the active and reactive power or energy, as well for power quality monitoring. The measurement will be done in three-phase system or in three separate single-phase systems with the accuracy of class 1 (1%)

In the accuracy class 1 according to EN 62053-31 only accuracy requirements for the measurement range between 2% and 100% of rated current are determined. For smaller currents no requirements are defined, as these can not be accurately detected with conventional current transformers. In contrast, the Enertex KNX Smartmeter uses high precision (Rogowski-) current sensors which are calibrated to the device in factory. Thus, very small currents to 0.002% (2mA) of rated current are accurately measurable. In addition, the current is measured with very little loss (< 2mW loss). The provided current sensors are suitable for through-hole mounting and can be installed directly at the main supply point of the grid.

The Smartmeter is powered exclusively via the bus. Therefore, the device can even be operated if there is no voltage at the voltage inputs or the voltage has been separated.

The measurement range of the active power extends from 0.5W to 19.550W or 58.650W (three-phase). Energy values or measurement values for monitoring the power quality can be recorded for analysis on a SD card.

All measured values (current, voltage, active power, reactive power, active energy, reactive energy, power factor, THD-U, THD-I, power harmonics, unbalanced load, zero current, power frequency) are shown on the KNX bus.

Besides specialized functions for performance-based load control, optimization of the inherent energy demand with PV facilities, calculating the usage or feeding charge with tariff switching the ETS application also provides various monitoring functions. In case of exceed of limits these functions report events as power outages, high voltage spikes, high power distortion, high reactive energy, highly non-uniform loading of the three phases (unbalanced load) or high neutral loading on the bus. To assess the power quality harmonics up to the 50th harmonic of current and voltage are measured. The numerous monitoring features enable fast accurate analysis of network-related failures, malfunctions and damages of electrical equipment.

The device variant with the RT option can also be operated without a KNX bus. To do this, a 24VDC power supply must be connected to the KNX terminal. In this mode, all measurement data of the recording mode "All measured values without mains harmonics" are recorded on the SD card every minute as described in the section "Recording on the SD card". The recording times for the measured values are selected in this mode according to an internal battery-buffered clock, which is factory set to the local time of Berlin (UTC / GMT +1 hour) and deviates from the real time by a maximum of one minute per year. If necessary, the clock can be adjusted using the SD card. The adjustment of the clock without KNX bus is described in section "Adjusting the real-time clock without bus access".

Note: The security against tampering of the current counter, required for billing purposes, can not be guaranteed with this Smartmeter. Therefore this KNX device is not a current counter for billing purposes in terms of the standard (for example IEC 62052-11).

Technical specifications

KNX	Voltage:	DC 21 ... 32 V SELV
	Current consumption:	< 18mA
	Typical power consumption:	0.28W

Connections	<p>Voltage measurement input: 4 pol. screw terminal Cross section: 0,33 ... 4 mm² / AWG 22 ... 12 Input voltage: max. 460Vrms Power frequency: 50Hz</p> <p>Current sensor input: 3 x 3 pol. screw terminal Cross section: 0.2 ... 4 mm² / AWG 24 ... 12</p> <p>Ground terminal: 3 pol. screw terminal for functional earth, internal bridged Cross section: 0.2 ... 4 mm² / AWG 24 ... 12</p> <p>Max. cross section through current sensor: 25 mm² / AWG3</p> <p>EIB / KNX Connection: Connector Type 5.1</p>
Installation	<p>Scope of application: For use indoors</p> <p>Protection type: IP20</p> <p>Ambient temperature: -5 °C ... 45°C</p> <p>Protection class: II</p> <p>Over voltage category for voltage input: 400Vrms / CAT IV</p>
Housing	<p>Type: DIN rail housing for 35 mm rail</p> <p>Width: 4 Units</p> <p>Dimensions: 70,0 x 89,6 x 62,9 mm (L x W x H)</p> <p>Flammability: UL94-V0</p>
General	<p>Certification: EIB/KNX certificated</p> <p>Applicable standards for CE-marking: Tested for safety in accordance with DIN EN 61010-1 Tested for EMC compliance in accordance with DIN EN 50491-5 Meets requirements for households according to DIN EN 50491-5-2 and for industrial according to DIN EN 50491-5-3</p>
Supplied accessories	<p>Current sensors: 3 x current sensor (Rogowski-converter) with each 1,5m Measurement line and centering clip</p> <p>SD-card: Micro SD card with adapter</p>
Measurement values	<p>Current, Voltage, Active power, Reactive power, Active energy, Reactive energy, Power factor, THD-U, THD-I, Unbalanced load, Zero current, Power frequency, Power harmonics up to the 50th harmonics</p>
Accuracy class	<p>Active energy according to DIN EN 62053-21: 1 (1%)</p> <p>Starting current: 2mA (rms value)</p> <p>Max. current (I_{max}): 85A (rms value)</p>

Measurement-accuracy	Active power:	
	Measurement ranges	Typical measurement deviations per channel
	0,5W ... 2W:	< 10% or 0.1W
	2W ... 20W:	< 5%
	20W ... 20kW:	< 1%
	Current:	
	Measurement ranges	Typical measurement deviations
	1mA ... 10mA:	< 5% or 0.5mA
	10mA ... 100mA:	< 2%
	100mA ... 85A:	< 1%
	Voltage:	
	Measurement range	Typical measurement deviation
30V ... 460V:	< 0.5%	
Frequency:		
Measurement range	Typical measurement deviation	
40Hz ... 60Hz:	< 0.1%	
THD-I, Harmonics I:		
Measurement ranges	Typical measurement deviations (at 5Arms rating current)	
0% ... 10%:	< 0.2% absolute	
10% ... 100%:	< 1% absolute	
THD-U, Harmonics U:		
Measurement ranges	Typical measurement deviations (at 230Vrms rating voltage)	
0% ... 10%:	< 0.2% absolute	
10% ... 100%:	< 1% absolute	

Assembly

Connection diagram

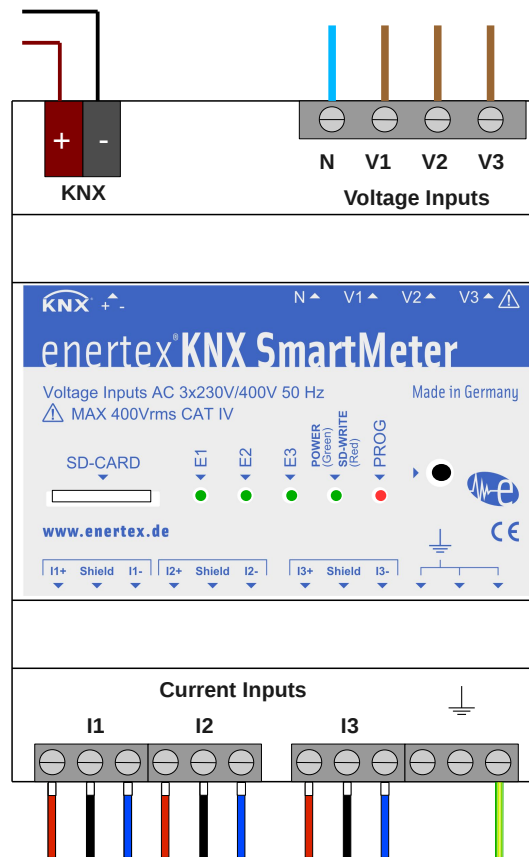

Figure 1: Terminal connection diagram

ATTENTION DANGER!

Electrical shock on contact with live parts. Electrical shock can result in death. Disconnect the mains before working on device and cover up live parts in the vicinity!

The neutral conductor and the measurement inputs for the 3 voltage measurement channels V1, V2 and V3 are connected to the overlying screw terminal. When measuring a three-phase system the phases L1, L2 and L3 have to be connected to V1, V2 and V3. If the Smartmeter is not in three-phase operation then the phase voltage of the corresponding current channel has to be connected to voltage measurement channel V1, V2 and V3. For example, if three powers are to be measured at one single phase, then this phase has to be connected to all three channels V1, V2 and V3. The supply for the voltage inputs may be made from any location downstream the main fuse, since the voltage inputs are designed for over voltage category IV. Insulation and electro-magnetic immunity is designed for overvoltage category 4. So, the voltage inputs need not to be additionally fused.

The EIB/KNX bus is connected on the upper left, grey / red terminal. The Smartmeter is powered solely by the KNX bus.

Optionally a ground can be connected to one of the three ground terminals. By a connected grounding the measurement accuracy for very small currents and powers is increased. Thus, when measuring the current, the measurement deviation is reduced by about 0.3mA or when measuring the power the deviation is reduced by about 70mW. By connecting the grounding the KNX bus is connected via a capacitance of 15nF to ground.

The current sensors have to be connected to the lower terminals of the Smartmeter with the following assignment:

- I+ : brown
- I- : white
- Shield : black (drain wire)

Assembly of the current sensors

The current-carrying conductor, to be measured, must be passed through the current sensor. If possible, the line should be passed vertically through the current sensor. Thus, the highest precision is achieved in the current measurement. In order to fix the current sensor, it could be fixed with a cable strap at the conductor. It is recommended for safety reasons to lead the conductor with insulation through the current sensor.

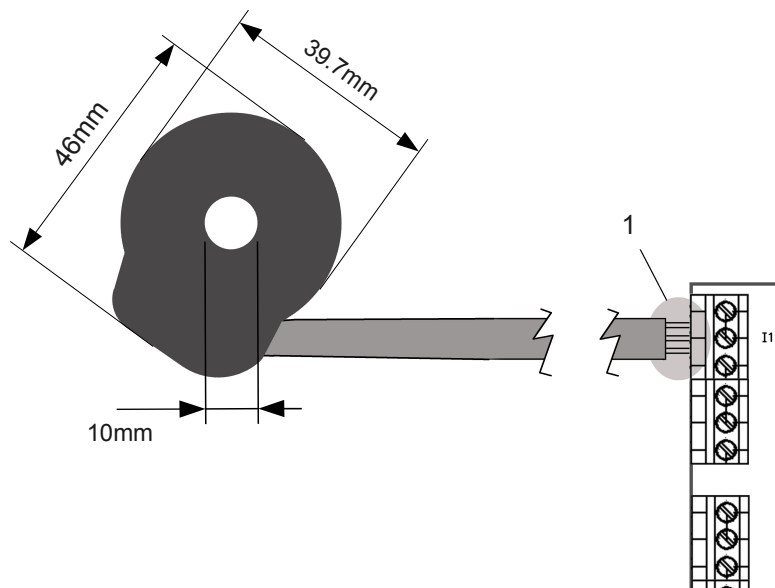

Figure 2: Dimensions of the 85A current sensor in mm

Safety note: In the vicinity of label 1 of Figure 2 the current sensors cable is only single insulated. At this point a safety distance of at least 5mm has to be adhered to all non insulated live conductors. Similarly a safety distance of at least 10mm from the screw terminals has to be adhered to all non insulated live conductors. However, the sheath of the line for the current sensors has a reinforced insulation. Hereby no safety distances to the vicinity are required.

Since the current sensors are calibrated for each current channel it must be ensured that the accompanying current sensors are connected to the corresponding channel. For this purpose a corresponding marking of the channel is mounted on each current sensor. In addition, the current sensors should be connected only to that Smartmeter, with which they were delivered. To avoid any confusion, the serial number of the Smartmeter is attached to the line of a current sensor. The serial number can also be recovered lateral of each Smartmeter.

A power count arrow (for positive power count direction) is attached by $\overset{P+}{\rightarrow}$ on the current sensors. A power flow in this direction corresponds to a positive power value. Usually, the current sensors are mounted so that the power count arrow shows from the energy source to the energy consumers, so that an energy consumption has a positive impact for the balance energy counter.

The lines to the current sensors should be laid according to EMC requirements. This is especially important when a high accuracy for currents below 100mA (equivalent to 25W) is required. Therefore the following recommendations are made:

- The line should be laid in a minimum distance of 2cm to power lines.

- The line should be laid at a distance of at least 10cm to high-frequency sources of interference. These include for example:
 - Inverter, converter
 - WLAN Router
 - Counter with GSM interface
 - Equipment of a radio - bus, as EnOcean, KNX-RF ...

For the highest precision the lines to the current sensors can also be cut to the minimum required length. When shortening it is to make sure that also the drain wire is connected to the shield terminal. In addition, care must be taken that after shortening, the cable shield is again insulated by a shrinking tube, as it was the case in the original condition. As an alternative to this insulation the electrical safety can also be ensured by maintaining a safety distance between the non - insulated part of the shield and all the live conductors by at least 10mm.

If necessary, it is also possible to extend the lines for the current sensors up to 10m. However, an increasing cable length is accompanied by a higher disturbance in the measurement signal. Thus, the measurement accuracy for small currents is reduced. It is therefore recommended not to extend the line, if currents below 500mA (about 100W) shall be accurately measured. To affect the measurement accuracy as little as possible in a case of an extension the following is recommended:

- Only use shielded lines with at least 0.5mm² . The shield of the extension must be connected to the shield wire (drain wire) of the existing measurement line.
- The extension should be soldered to the existing measurement line.
- The shield of the extension or the extension drain wire must be connected to the Smartmeter at the shield terminal.

For safety reasons the extension has to be attached so that from the shield and the wires of the extension to all live parts in the vicinity of the extension a double or reinforced insulation is maintained. This can be achieved by insulation and/or the observance of minimum distances.

Commissioning

After connecting all the cables according to the connection diagram 1 the device is ready for operation. Once the KNX bus is connected, the "POWER" LED lights up permanently green after a short start-up (about 3 seconds). From that time the device performs measurements continuously.

By a short light up the channel LEDs E1, E2 and E3 signalize measuring an energy amount of 1/1000 kWh in the particular channel. When the Smartmeter record data onto the SD card, the POWER LED lights up red during the writing process. To prevent data loss on the SD card the SD card may not be drawn during this writing phase. SD card is inserted in a way, that the contacts of the SD card are on the top.

ETS-Application

Specification

ETS: from Version 3.0d, Patch A

Data base file

In <http://www.enertex.de> see the current ETS database file and the current product description.

Examples of settings

Below examples are presented, which show how the KNX Smartmeter can be used. To this end appropriate adjustments in the ETS will be shown. The adjustments can be adopted directly.

Example 1: Visualization of energy consumption

In the first example the progress of energy consumption and the progress of the energy costs of a residential house shall be recorded and shown on the bus. The consumption values transmitted on the bus can be visualized for example on the web server of Enertex EibPC over the last 30 hours.



Figure 3: Example of the visualization of energy consumption

Furthermore it is shown in this example, how the progress of the three-phase active power can be displayed completely on the bus and the Smartmeter is configured such, that it also records all measurement values on the SD card every 15 minutes.

In this example the following topics are treated: Installation of the Smartmeter, tariff counter, intermediate counter, preempting a count, SD card, transmitting in case of change and time.

In this example the installation of the Smartmeter is a three-phase at the house connection. Generally the current sensors are installed directly downstream the current counter of the energy supplier. Similarly the voltage may be tapped directly downstream the current counter.

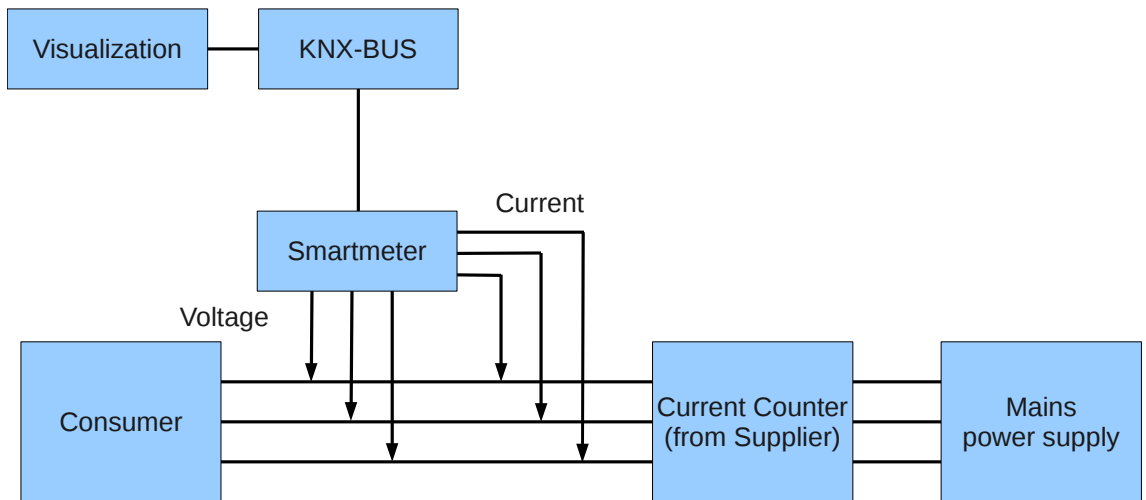

Figure 4: Connection of Smartmeter to record the total energy consumption of a residential building

When connecting make sure that the current sensors are oriented such, that the applied power arrows show from the public supply network in direction of consumers within the home. Next, make sure that voltage L1 is connected to V1, voltage L2 to V2 and voltage L3 to V3. Likewise, the current sensor at conductor L1 has to be connected to I1, the current sensor at conductor L2 to I2 and the current sensor at L3 to I3..

Attention: If a channel is reversed, the measured values for the active power and active energies are distorted strongly.

After connecting the lines according to the connection plan the device is ready for operation. Once the KNX-bus is connected, the "POWER" LED lights up permanently after a short start-up procedure (about 3 seconds). From that time the device performs measurements permanently. If not already done the SD card for recording the measurement data has to be inserted.

Below is shown, which relevant parameter related to this example has to be set in the ETS.

In the tab "General" the parameter "Request time and date after bus voltage recovery" should be set. Otherwise the default values can be adopted. By setting the parameter the Smartmeter requests once after each restart of the application the current time and date from the bus. This data must be provided from an other device in via a group address. If no device exists on the bus, which provides a time then this example can not be applied. The time is needed since the Smartmeter transmit the measurement values always synchronized with the day time on the bus, e.g. on the minute or hour. The time is also needed for the timely recording of the measurement data on the SD card.

Therefore the tab "General" has to be parameterized as follows:

1.1.1 KNXSmartmeter > General		
General	Transmission delay after bus voltage recovery (s)	2
Measurement	Transmission delay when sending intermediate counter values (s)	2
Measurement - three-phase	Request time and date after bus voltage recovery	<input checked="" type="radio"/> Yes <input type="radio"/> No
Energy counter/Tariff cost cou...	Value of group object 'Request Time'	<input checked="" type="radio"/> 0 <input type="radio"/> 1
Energy counter - three-phase	Transmit group object 'In operation' (s)	0
Tariff cost counter - three-p...	Value of group object 'In operation'	<input checked="" type="radio"/> 0 <input type="radio"/> 1
Tariff		
Tariff 1		
Tariff 2		

Figure 5: Settings „General“ Example 1

The settings in the tab “Measurement” can be seen in Figure 6. It is advisable that in the parameter “Reference current for limit values (x5A)” the security value is entered with which the lines at the measurement point of the Smartmeter are protected. In this example the reference value is therefore adjusted to 35A corresponding to the protection fuse of the house connection. Therefore a parameter with the value 7 is entered in “Reference current for limit values (x5A)”. This setting results in a viable range of values for the subsequent indication of current and power limits.

Since only the measurement of three-phase values is relevant in this example, only these are released in the settings. Otherwise the default values can be adopted. With the default settings for the SD card recording, all measured values except the harmonics are recorded on the SD card. With a parameterized recording interval of “15min” each 15 minutes a record of all measurements (currents, voltages, powers, energy counter, THDs, frequency, power factors, current and voltage peaks) on the SD card is done. The measurements are written in CSV format to a file. At the beginning of each new day a new recording file is generated. Thus, the data on the SD-card are ordered by day to a certain extent. The csv-files can directly be opened and processed by a spreadsheet program such as Excel, Openoffice Calc or Gnumeric.

1.1.1 KNXSmartmeter > Measurement		
General	Reference current for limit values (x5A)	7
Measurement	Release frequency Measurement	<input type="radio"/> Yes <input checked="" type="radio"/> No
Measurement - three-phase	SD card recording mode	All measurements without harmonics
Energy counter/Tariff cost cou...	SD card recording interval	15min
Energy counter - channel 1	Release group object 'Request measured values'	<input type="radio"/> Yes <input checked="" type="radio"/> No
Energy counter - channel 2	Release group object 'Request power values'	<input type="radio"/> Yes <input checked="" type="radio"/> No
Energy counter - channel 3	Release channel 1	<input type="radio"/> Yes <input checked="" type="radio"/> No
Energy counter - three-phase	Release channel 2	<input type="radio"/> Yes <input checked="" type="radio"/> No
Tariff cost counter - three-p...	Release channel 3	<input type="radio"/> Yes <input checked="" type="radio"/> No
Intermediate counter 1	Release three-phase values	<input checked="" type="radio"/> Yes <input type="radio"/> No
Intermediate counter 2		
Intermediate counter 3		

Figure 6: Settings „Measurement“ Example 1

In the next tab “Measurement three-phase” can be parameterized, which three-phase values are to be transmitted on the bus.

1.1.1 KNXSmartmeter > Measurement - three-phase	
General	Transmit three-phase values cyclically <input type="radio"/> Yes <input checked="" type="radio"/> No
Measurement	Transmit power and current measurements at change <input checked="" type="radio"/> Yes <input type="radio"/> No
Measurement - three-phase	Transmit measured values at change (in % of current measured value) <input type="text" value="5"/>
Energy counter/Tariff cost cou...	Transmit active power at change <input checked="" type="radio"/> Yes <input type="radio"/> No
Energy counter - three-phase	Transmit apparent power at change <input type="radio"/> Yes <input checked="" type="radio"/> No
Tariff cost counter - three-p...	Transmit reactive power at change <input type="radio"/> Yes <input checked="" type="radio"/> No
Intermediate counter 1	Transmit zero current at change <input type="radio"/> Yes <input checked="" type="radio"/> No
Intermediate counter 2	Message at limit value (three-phase-active power) <input type="radio"/> Yes <input checked="" type="radio"/> No
Tariff	Message at limit value (reactive power) <input type="radio"/> Yes <input checked="" type="radio"/> No
Tariff 1	Message at limit value (unbalanced load) <input type="radio"/> Yes <input checked="" type="radio"/> No
	Message at limit value (zero current) <input type="radio"/> Yes <input checked="" type="radio"/> No

Figure 7: Settings „Measurement three-phase“ Example 1

If, as in this example, the three-phase power shall be displayed on the bus seamlessly, the panel “Transmit power and current measurements at change” has to be enabled. Then further buttons are opened, with which this function can be specified. In the panel “Transmit measured values at change” a percentage rate of 5% is indicated. Thus, a new measured value is transmitted, if the measured value has been changed by more than 5% with respect to the value last transmitted on the bus. With this setting the measurement on the bus can be effectively tracked without which the bus is flooded with unnecessary messages. If the number of messages is still too high with this settings, then the number of transmitted messages can be reduced by increasing the percentage value. However, this goes hand in hand that the measured values can be tracked by the bus with less accuracy. Here a appropriate compromise depending on the fluctuation of the consumption loads should be found between the deviation of the indication from the current measurement and the operational demands of the bus. Finally it should be configured, which measurements are to transmit in cases of changes. Since only the active power is of interest, only that button is activated.

In the following tab “Energy counter/ Tariff cost counter” from Figure 8 the used counter can be released. Since in this example only the three-phase consumption and its costs are to be visualized, only the energy counter “Energy counter three-phase” and the cost counter “Tariff cost counter 1” is released. Furthermore two other so-called intermediate counter are required in this example to transmit quarter-hour-consumptions and to transmit daily consumption costs (=daily cost of electricity). These counters are released as well:

1.1.1 KNXSmartmeter > Energy counter/Tariff cost counter		
General	Release energy counter - channel 1	<input type="radio"/> Yes <input checked="" type="radio"/> No
Measurement	Release energy counter - channel 2	<input type="radio"/> Yes <input checked="" type="radio"/> No
Measurement - three-phase	Release energy counter - channel 3	<input type="radio"/> Yes <input checked="" type="radio"/> No
Energy counter/Tariff cost co...	Release energy counter - three-phase	<input checked="" type="radio"/> Yes <input type="radio"/> No
Energy counter - three-phase	Release tariff cost counter - three-phase	<input checked="" type="radio"/> Yes <input type="radio"/> No
Tariff cost counter - three-p...	Release tariff cost counter 1	<input checked="" type="radio"/> Yes <input type="radio"/> No
Intermediate counter 1	Release tariff cost counter 2	<input type="radio"/> Yes <input checked="" type="radio"/> No
Intermediate counter 2	Release tariff cost counter 3	<input type="radio"/> Yes <input checked="" type="radio"/> No
Tariff	Release intermediate counter 1	<input checked="" type="radio"/> Yes <input type="radio"/> No
Tariff 1	Release intermediate counter 2	<input checked="" type="radio"/> Yes <input type="radio"/> No
	Release intermediate counter 3	<input type="radio"/> Yes <input checked="" type="radio"/> No
	Release intermediate counter 4	<input type="radio"/> Yes <input checked="" type="radio"/> No
	Release intermediate counter 5	<input type="radio"/> Yes <input checked="" type="radio"/> No
	Release intermediate counter 6	<input type="radio"/> Yes <input checked="" type="radio"/> No

Figure 8: Settings „Energy counter/Tariff costs counter“ Example 1

In the following two tabs “Energy counter - three-phase” and “Tariff costs counter - three-phase” no adjustments have to be done. Here the default values are taken.

Now the energy counter in the tab “Intermediate counter 1” is configured to count the quarter-hour consumption. For this the “Input counter value of intermediate counter” has to be set to “Active energy counter (consumption) - three-phase”. The counting interval is set to “15min”. Furthermore the setting “Transmit counter value before resetting” is enabled:

1.1.1 KNXSmartmeter > Intermediate counter 1		
General	Input counter value of intermediate counter	Active energy counter (consumption) - three-p... ▾
Measurement	Count interval	15min ▾
Measurement - three-phase	Transmit counter value before resetting	<input checked="" type="radio"/> Yes <input type="radio"/> No
Energy counter/Tariff cost cou...	Transmit counter values cyclically (x10s)	0 ▾
Energy counter - three-phase	Message at limit value	<input type="radio"/> Yes <input checked="" type="radio"/> No
Tariff cost counter - three-p...	Limit value (Wh)	0 ▾
Intermediate counter 1		
Intermediate counter 2		
Tariff		
Tariff 1		

Figure 9: Settings „Intermediate counter 1“ Example 1

With this configuration the intermediate counter sums up the three-phase energy consumption each about 15 minutes and transmits this amount on the bus at the end of the interval. After that the intermediate counter resets and adds the energy consumption again. Thereby the time intervals are synchronized with the day time, so that the time intervals only start and end at times XX:00 (=every hour), XX:15 and XX:45. Thus, these counters can also measure synchronous to other current counters. Finally the 3-phase energy consumption of the last 15 minutes is transmitted cyclically after each quarter of an hour by this parametrization. Thereby

the energy consumption of intermediate counter 1 is transmitted by the group object “Energy counter-previous value” on the bus. The energy consumption is transmitted in the unit Wh.

Similarly, the intermediate counter 2 is configured to transmit each daily energy costs at the end of a day on the bus. For this purpose “Tariff cost counter (consumption) - tariff 1” is used as input value in intermediate counter 2. The counting interval is set to “24h” Furthermore the adjustment “Transmit counter value before resetting” is enabled again:

1.1.1 KNXSmartmeter > Intermediate counter 2	
General	Input counter value of intermediate counter: Tariff cost counter (consumption) - tariff 1
Measurement	Count interval: 24h
Measurement - three-phase	Transmit counter value before resetting: <input checked="" type="radio"/> Yes <input type="radio"/> No
Energy counter/Tariff cost cou...	Transmit counter values cyclically (x10s): 0
Energy counter - three-phase	Message at limit value: <input type="radio"/> Yes <input checked="" type="radio"/> No
Tariff cost counter - three-p...	Limit value (Cent): 0
Intermediate counter 1	
Intermediate counter 2	
Tariff	
Tariff 1	

Figure 10: Settings „Intermediate counter 2“ Example 1

The energy costs which have been summed up over the day are then transmitted on the bus at the end of a day via the group object “Costs counter-previous value” of intermediate counter 2. The transmitted value represents the energy costs in cent.

Finally a tariff must still be specified to calculate the costs. Thereby “Tariff 1” is released in the tab “Tariff”. Then the parametrization of tariff 1 is done in tab “Tariff 1”:

1.1.1 KNXSmartmeter > Tariff 1	
General	Rate (0.01 ct/kWh): 3000
Measurement	Adopt rate from bus: <input checked="" type="radio"/> flighty <input type="radio"/> permanent
Measurement - three-phase	Tariff changeover tariff 1: always active
Energy counter/Tariff cost cou...	
Energy counter - three-phase	
Tariff cost counter - three-p...	
Intermediate counter 1	
Intermediate counter 2	
Tariff	
Tariff 1	

Figure 11: Settings „Tariff 1“ Example 1

In the panel “Rate” the electricity rate is given in 0.01 ct/kWh. This means for a given current rate of e.g. 30ct/kWh a value of 3.000 has to be specified here. Furthermore it has to be specified here when the tariff shall be valid. In this simple example only one electricity tariff should be configured, which is valid around the clock. For this purpose the entry “always active” is selected in the panel “Tariff changeover tariff 1”.

The parametrization presented in this section causes the Smartmeter to transmit the following group objects cyclically: “Energy counter-previous value” (ID 105), “Costs counter-previous value” (ID 115), “Active power” (ID: 64).

If these group objects are linked with group addresses, then they can be very easily visualized in

a time-diagram. Figure 3 shows one possible visualization of energy consumption in a chart on the web server of Enertex EibPC.

Finally it should be explained on the basis of this example, as the already existing current counter of Figure 4 can be synchronized with the Smartmeter. For this purpose the counter value from the existing current counter shall be entered on the register “Active energy counter (balance) - three-phase”. This can be performed using the ETS. Thereby the “Writing”-flag of the group object “Active energy counter (balance) - three-phase” has to be set. After the group object has been linked to a group address the application must be re-recorded. Now the counter value of the existing current counter can be written to the corresponding group address in the ETS group monitor. It should be noted that the value has previously to be converted from kWh into Wh. If necessary, the “Writing”-flag of the corresponding group object can then be removed again.

Example 2: Bidirectional Counter for Photovoltaics

In the second example the use of the Smartmeter as a bidirectional counter for a residential building with a PV-system will be demonstrated. The daily energy costs and the daily tariff for the PV-system are to be displayed on the bus. Thus, the energy costs and energy yields can be visualized, for example, over the last 6 months on a chart. In addition the progress of the energy fed by PV, the progress of the energy provided by the network and the balance of both are to be visualized over the last 24 hours.

Furthermore it is shown in this example, as a simple load management can be implemented using a single threshold. The load management shall contribute to the energy generated in the PV-system is preferably used to supply their own consumer loads rather than feeding into the net (for a relatively low feed-in rate).

In this example the following topics are treated: bidirectional counter, tariff counter, intermediate counter and limit values.

The installation of the Smartmeter in this example is 3-phase in the main connection of the grid. In general the current sensors are installed downstream the current counter of the energy supplier. Likewise, the voltage can be measured directly downstream the current counter:

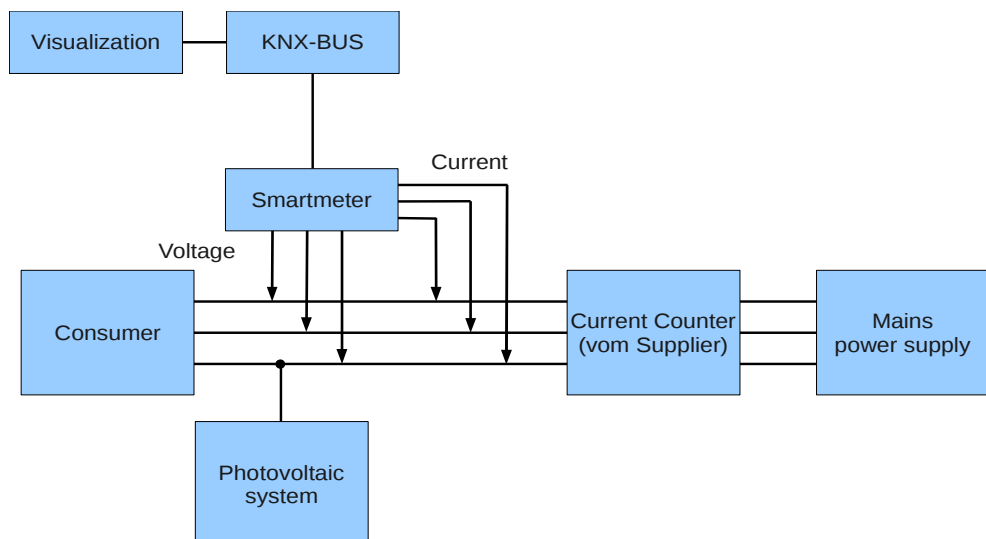

Figure 12: Connection of the Smartmeter in a residential building with PV-system

The example is irrespective of whether the PV-system is connected to the network single phase or three phase.

Below is shown which relevant parameters are to set in the ETS relating to this example.

In the tab “General” the parameter “Request time and date after bus voltage recovery” should be set. Otherwise the default values can be used:

1.1.1 KNXSmartmeter > General		
General	Transmission delay after bus voltage recovery (s)	2
Measurement	Transmission delay when sending intermediate counter values (s)	2
Measurement - three-phase	Request time and date after bus voltage recovery	<input checked="" type="radio"/> Yes <input type="radio"/> No
Energy counter/Tariff cost cou...	Value of group object 'Request Time'	<input checked="" type="radio"/> 0 <input type="radio"/> 1
Energy counter - three-phase	Transmit group object 'In operation' (s)	0
Tariff cost counter - three-p...	Value of group object 'In operation'	<input checked="" type="radio"/> 0 <input type="radio"/> 1
Tariff		
Tariff 1		
Tariff 2		

Figure 13: Settings „General“ Example 2

The settings in the tab “Measurement” can be seen in Figure 14. It is advisable that in the parameter “Reference current for limit values (x5A) the security value is entered with which the lines are protected at the measurement point of the Smartmeter. In the present example the reference value is set to 35A corresponding to the protection fuse of the house connection. Therefore a parameter with the value of 7 has to be entered in “Reference current for limit values (x5A)”. This setting results in a variable range of values for the subsequent indication of current and power limits.

Since only the measurement of three-phase values is relevant, only these are enabled in the settings. Otherwise, the default values can be used:

1.1.1 KNXSmartmeter > Measurement		
General	Reference current for limit values (x5A)	7
Measurement	Release frequency Measurement	<input type="radio"/> Yes <input checked="" type="radio"/> No
Measurement - three-phase	SD card recording mode	All measurements without harmonics
Energy counter/Tariff cost cou...	SD card recording interval	15min
Energy counter - channel 1	Release group object 'Request measured values'	<input type="radio"/> Yes <input checked="" type="radio"/> No
Energy counter - channel 2	Release group object 'Request power values'	<input type="radio"/> Yes <input checked="" type="radio"/> No
Energy counter - channel 3	Release channel 1	<input type="radio"/> Yes <input checked="" type="radio"/> No
Energy counter - three-phase	Release channel 2	<input type="radio"/> Yes <input checked="" type="radio"/> No
Tariff cost counter - three-p...	Release channel 3	<input type="radio"/> Yes <input checked="" type="radio"/> No
Intermediate counter 1	Release three-phase values	<input checked="" type="radio"/> Yes <input type="radio"/> No
Intermediate counter 2		
Intermediate counter 3		

Figure 14: Settings „Measurement“ Example 2

In the next tab “Measurement - three-phase values” the limit value of the three-phase active power for load management is parametrized. In principle the concept of load control is to work as follows:

If currently more energy is generated in the PV system than is consumed by the consumer loads at home, then the Smartmeter will measure a negative three-phase active power. Then energy is fed into the grid. In the opposite case the measured active power would be positive. The load management is to be designed so, that only the excess energy from the PV-system will be used for additional consumer loads. Therefore corresponding consumer loads have to be switched on as soon as the active power reaches a certain negative value. This threshold is determined on -966W in the example. If the active power becomes positive again, the consumer loads will be switched off again. Therefore this threshold is set to 0W. Between these two thresholds a buffer zone should be parametrized so that consumer loads do not continuously switched on or off.

This is realized by the hysteresis function.

With the following parametrization this concept can be implemented. The limit value for the three-phase active power is set to “-20” (= -2%). This corresponds to the following power:

$$35\text{A} \cdot (-2\%) \cdot 3 \cdot 230\text{V} = -483\text{W}$$

The value 35A corresponds to the parametrized reference current. The term $3 \cdot 230\text{V}$ is required to convert the reference current in a three-phase reference power. The value for the hysteresis is set to “-40” (= -4%). This corresponds to the following power:

$$35\text{A} \cdot (-4\%) \cdot 3 \cdot 230\text{V} = -966\text{W}$$

With the limit values and the hysteresis the following thresholds arise:

- Under threshold: $-483\text{W} - \frac{1}{2} \cdot (-966\text{W}) = 0\text{W}$
- Upper threshold: $-483\text{W} + \frac{1}{2} \cdot (-966\text{W}) = -966\text{W}$

If the three-phase active power reaches the upper threshold of -966W, the value 1 is transmitted to the group object “Active power limit message” (ID:66). In contrast, if the three-phase active power reaches the lower threshold of 0W, the value 0 is transmitted to the group object “Active power limit message” (ID:66). Exactly these values of the group object “Active power limit message” (ID:66) are needed for switching on/off a consumer load. So the “switching”-group object of the switching actuator of a consumer load has to be linked to the group object “Active power limit message” (ID:66) of the Smartmeter.

However, the connected consumer load has also be suitable for this automatic enabling or disabling. Possibly suitable consumer loads are for example electric heatings, heat pumps, boiler, cooling aggregates or charging devices.

A much less critical method than the automatic switching of consumer loads is just to have the energy excess displayed. Thus the residents are signaled by a green signal lamp at which time the current is cheap (green signal lamp on) or at which time the current is expensive (green signal lamp off). For this purpose the group object “Active power limit message” has to be linked to the group object of the switching actuator of the signal lamp.

For parametrization of the load management the following values have to be selected in the tab “Measurement- three-phase”:

1.1.1 KNXSmartmeter > Measurement - three-phase	
General	Transmit three-phase values cyclically <input type="radio"/> Yes <input checked="" type="radio"/> No
Measurement	Transmit power and current measurements at change <input type="radio"/> Yes <input checked="" type="radio"/> No
Measurement - three-phase	
Energy counter/Tariff cost cou...	Message at limit value (three-phase-active power) <input checked="" type="radio"/> Yes <input type="radio"/> No
Energy counter - three-phase	Adopt limit value from bus <input checked="" type="radio"/> flighty <input type="radio"/> permanent
Tariff cost counter - three-p...	Limit value (x0.1%) <input type="text" value="-20"/>
Intermediate counter 1	Hysteresis (x0.1%) <input type="text" value="-40"/>
Intermediate counter 2	Message at limit value (reactive power) <input type="radio"/> Yes <input checked="" type="radio"/> No
Intermediate counter 3	Message at limit value (unbalanced load) <input type="radio"/> Yes <input checked="" type="radio"/> No
Intermediate counter 4	Message at limit value (zero current) <input type="radio"/> Yes <input checked="" type="radio"/> No
Intermediate counter 5	
Tariff	

Figure 15: Settings „Measurement - three-phase“ Example 2

In the next tab “Energy counter/Tariff cost counter” in Figure 16 the applied counter are

released. Since in this example only the three-phase consumption and its costs are to be visualized, only the energy counter “Energy counter - three-phase”, the cost counter “tariff costs counter 1” and “Tariff costs counter 2” are released. Furthermore 3 intermediate counter are required to represent the energy consumption, the energy supply and the balancing energy over the course of one day on the bus. Two other intermediate counter are used to represent the daily energy supply costs and the daily compensation for electricity fed into the grid:

1.1.1 KNXSmartmeter > Energy counter/Tariff cost counter		
General	Release energy counter - channel 1	<input type="radio"/> Yes <input checked="" type="radio"/> No
Measurement	Release energy counter - channel 2	<input type="radio"/> Yes <input checked="" type="radio"/> No
Measurement - three-phase	Release energy counter - channel 3	<input type="radio"/> Yes <input checked="" type="radio"/> No
Energy counter/Tariff cost co...		
Energy counter - three-phase	Release energy counter - three-phase	<input checked="" type="radio"/> Yes <input type="radio"/> No
Tariff cost counter - three-p...	Release tariff cost counter - three-phase	<input checked="" type="radio"/> Yes <input type="radio"/> No
Intermediate counter 1	Release tariff cost counter 1	<input checked="" type="radio"/> Yes <input type="radio"/> No
Intermediate counter 2	Release tariff cost counter 2	<input checked="" type="radio"/> Yes <input type="radio"/> No
Intermediate counter 3	Release tariff cost counter 3	<input type="radio"/> Yes <input checked="" type="radio"/> No
Intermediate counter 4	Release intermediate counter 1	<input checked="" type="radio"/> Yes <input type="radio"/> No
Intermediate counter 5	Release intermediate counter 2	<input checked="" type="radio"/> Yes <input type="radio"/> No
Tariff	Release intermediate counter 3	<input checked="" type="radio"/> Yes <input type="radio"/> No
Tariff 1	Release intermediate counter 4	<input checked="" type="radio"/> Yes <input type="radio"/> No
Tariff 2	Release intermediate counter 5	<input checked="" type="radio"/> Yes <input type="radio"/> No
	Release intermediate counter 6	<input type="radio"/> Yes <input checked="" type="radio"/> No

Figure 16: Settings „Energy counter/Tariff cost counter“ Example 2

In the following two tabs “Energy counter - three-phase” and “Tariff cost counter - three-phase” no settings have to be made. Here the default values are used.

In the tab “Intermediate counter 1” the energy counter is configured to count the energy delivery. For this purpose the “Input count value of the intermediate counter” has to be set to “Active energy counter (consumption) - three-phase”. The count interval is set to “15min”. Furthermore the setting “Transmit counter value before resetting” is enabled:

1.1.1 KNXSmartmeter > Intermediate counter 1		
General	Input counter value of intermediate counter	Active energy counter (consumption) - three-p... ▾
Measurement	Count interval	15min ▾
Measurement - three-phase	Transmit counter value before resetting	<input checked="" type="radio"/> Yes <input type="radio"/> No
Energy counter/Tariff cost co...	Transmit counter values cyclically (x10s)	0 ▾
Energy counter - three-phase	Message at limit value	<input type="radio"/> Yes <input checked="" type="radio"/> No
Tariff cost counter - three-p...	Limit value (Wh)	0 ▾
Intermediate counter 1		
Intermediate counter 2		

Figure 17: Setting „Intermediate counter 1“ Example 2

With this configuration the intermediate counter sums up the delivery of three-phase energy, that is only the energy flux in positive power flux direction, each about 15 minutes and transmits this sum on the bus at the end of the interval. After that the intermediate counter resets and starts

again summarizing the delivery of energy. Thereby the time intervals are synchronized with the day time, so that the counting intervals only start and end at times XX:00 (=every hour), XX:15 and XX:45. Finally the 3-phase energy delivery of the last 15 minutes is transmitted cyclically after each quarter of an hour by this parametrization. Thereby the delivery of energy of intermediate counter 1 is transmitted via the group object “Energy counter-previous value” on the bus. The delivery of energy is transmitted in unit Wh.

Similarly the “Intermediate counter 2” is configured to transmit the energy fed into the grid every 15 minutes on the bus:

1.1.1 KNXSmartmeter > Intermediate counter 2	
General	Input counter value of intermediate counter Active energy counter (generation) - three-pa...
Measurement	Count interval 15min
Measurement - three-phase	Transmit counter value before resetting <input checked="" type="radio"/> Yes <input type="radio"/> No
Energy counter/Tariff cost cou...	Transmit counter values cyclically (x10s) 0
Energy counter - three-phase	Message at limit value <input type="radio"/> Yes <input checked="" type="radio"/> No
Tariff cost counter - three-p...	Limit value (Wh) 0
Intermediate counter 1	
Intermediate counter 2	
Intermediate counter 3	

Figure 18: Settings „Intermediate counter 2“ Example 2

By selecting the counter value “Active energy counter (generation) - three-phase” only the energy flux is counted in negative power flux direction.

Finally in “Intermediate counter 3” the counter is configured for the balanced energy:

1.1.1 KNXSmartmeter > Intermediate counter 3	
General	Input counter value of intermediate counter Active energy counter (balance) - three-phase
Measurement	Count interval 15min
Measurement - three-phase	Transmit counter value before resetting <input checked="" type="radio"/> Yes <input type="radio"/> No
Energy counter/Tariff cost cou...	Transmit counter values cyclically (x10s) 0
Energy counter - three-phase	Message at limit value <input type="radio"/> Yes <input checked="" type="radio"/> No
Tariff cost counter - three-p...	Limit value (Wh) 0
Intermediate counter 1	
Intermediate counter 2	
Intermediate counter 3	

Figure 19: Settings „Intermediate counter 3“ Example 2

In contrast to the “Active energy counter (consumption)” and “Active energy counter (generation)” the “Active energy counter (balance)” counts all the time. Its counter value can increase or decrease, whereas the consumption counter only increase and the generation counter only decrease. With the balancing counter neither the energy costs or the compensation can be calculated. Nevertheless the course of the day of the balancing counter shall be recorded, as seen directly from this, to what extend the purchase of an additional battery storage for solar energy would be useful.

The “Intermediate counter 4” is used to calculate the daily energy delivery costs. As a counter value it has to be used a “Tariff costs counter (consumption)”. Thus, this counter only counts, when energy flows in positive power flux direction. As later in the example the delivery rate for the current is deposited in the rate of tariff 1, the “Tariff costs counter (consumption) - tariff 1” has to be used as a counter value:

1.1.1 KNXSmartmeter > Intermediate counter 4	
General	Input counter value of intermediate counter Tariff cost counter (consumption) - tariff 1
Measurement	Count interval 24h
Measurement - three-phase	Transmit counter value before resetting <input checked="" type="radio"/> Yes <input type="radio"/> No
Energy counter/Tariff cost cou...	Transmit counter values cyclically (x10s) 0
Energy counter - three-phase	Message at limit value <input type="radio"/> Yes <input checked="" type="radio"/> No
Tariff cost counter - three-p...	Limit value (Cent) 0
Intermediate counter 1	
Intermediate counter 2	
Intermediate counter 3	
Intermediate counter 4	
Intermediate counter 5	

Figure 20: Settings „Intermediate counter 4“ Example 2

The counting interval is configured to 24 hours. Thus, the energy delivery costs are summed up each over a day and transmitted to the bus via the group object “Cost counter-previous value” of intermediate counter 4 at the end of the day. The transmitted value represents the daily energy delivery cost in cent.

Similarly, the “Intermediate counter 5” is used to sum up the daily compensation and to transmit on the bus. To calculate the compensation only the energy flux in negative power flux direction may be used. Therefore a “Tariff cost counter (generation)” is necessary here, which only counts on negative power flux direction.

Moreover this costs counter shall use the rate of tariff 2. In this tariff the compensation will be specified ct/kWh in a later time. Therefore “Tariff cost counter (generation) - tariff 2” is selected for the counter value:

1.1.1 KNXSmartmeter > Intermediate counter 5	
General	Input counter value of intermediate counter Tariff cost counter (generation) - tariff 2
Measurement	Count interval 24h
Measurement - three-phase	Transmit counter value before resetting <input checked="" type="radio"/> Yes <input type="radio"/> No
Energy counter/Tariff cost cou...	Transmit counter values cyclically (x10s) 0
Energy counter - three-phase	Message at limit value <input type="radio"/> Yes <input checked="" type="radio"/> No
Tariff cost counter - three-p...	Limit value (Cent) 0
Intermediate counter 1	
Intermediate counter 2	
Intermediate counter 3	
Intermediate counter 4	
Intermediate counter 5	

Figure 21: Settings „Intermediate counter 5“ Example 2

As already mentioned, the rates for current delivery and for current feeding have to be provided for the two cost counters. The specification have to be done under the heading “Tariff”. The “Tariff 1” is used for the energy delivery tariff and the “Tariff 2” for the feed-in tariff. Therefore these both tariffs are to release in the tab “Tariff”.

In the tab “Tariff 1” the current rate is indicated to 0.01 Cent/kWh. This means with e.g. a current rate of 30ct/kWh a value of 3000 has to be specified here. Furthermore it has to be parametrized here, when the tariff is to apply. In this simple example only a single current tariff should be configured, which is valid around the clock. For this purpose the selection in “Tariff changeover tariff 1” is selected to “always active”:

1.1.1 KNXSmartmeter > Tariff 1	
General	Rate (0.01 ct/kWh) <input type="text" value="3000"/>
Measurement	Adopt rate from bus <input checked="" type="radio"/> flighty <input type="radio"/> permanent
Measurement - three-phase	
Energy counter/Tariff cost cou...	Tariff changeover tariff 1 <input type="text" value="always active"/>
Energy counter - three-phase	
Tariff cost counter - three-p...	
Intermediate counter 1	
Intermediate counter 2	
Intermediate counter 3	
Intermediate counter 4	
Intermediate counter 5	
Tariff	
Tariff 1	
Tariff 2	

Figure 22: Settings „Tariff 1“ Example 2

Similarly, the feed-in tariff is specified in the panel of “tariff 2”. To count positive income a negative rate may be indicated here. In this case the active energy counter (generation) - three-phase, which always contains, by definition, a negative value, is multiplied by a negative rate. It results in a positive yield, which, for example, represents the yield of a PV-system. Therefore the entering of the feed-in compensation of 11.56ct has a negative sign:

1.1.1 KNXSmartmeter > Tariff 2	
General	Rate (0.01 ct/kWh) <input type="text" value="-1156"/>
Measurement	Adopt rate from bus <input checked="" type="radio"/> flighty <input type="radio"/> permanent
Measurement - three-phase	
Energy counter/Tariff cost cou...	Tariff changeover tariff 2 <input type="text" value="always active"/>
Energy counter - three-phase	
Tariff cost counter - three-p...	
Intermediate counter 1	
Intermediate counter 2	
Intermediate counter 3	
Intermediate counter 4	
Intermediate counter 5	
Tariff	
Tariff 1	
Tariff 2	

Figure 23: Settings „Tariff 2“ Example 2

Generally also the feed-in rate is not depending on the time of day. Therefore the tariff switching is deactivated by selecting of “always active”.

The parametrization which is presented in this section causes the Smartmeter to transmit the following group objects: "Energy counter-previous value" for the intermediate counter 1 (ID: 105), "Energy counter-previous value" for the intermediate counter 2 (ID: 113), "Energy counter-previous value" for the intermediate counter 3 (ID: 121), "Cost counter-previous value" for the intermediate counter 4 (ID: 131) and "Cost counter-previous value" for the intermediate counter 5 (ID: 139).

If these group objects are linked with group addresses, then they can be easily visualized in a time-diagram.

Measurement quantities

In this section an overview of the measurement quantities is given, which are measured by the Smartmeter. In the following table also the data type is specified, with which the group object can be processed in the Enertex EibPC. The definition of the sign of the power and the power factor is shown in Figure 24.

Description of the measurement quantities:

Name	KNX Data type (dpt.)	Data type for Enertex EibPC	Description
Frequency	14.033 DPT_Value_Frequency in Hz	f32 in Hz	Instantaneous frequency of grid. The frequency is determined from the voltage of channel 1.
Voltage	9.020 DPT_Value_Volt in mV	f16 in mV	Instantaneous voltage as a root mean square (RMS).
Current	9.021 DPT_Value_Curr in mA	f16 in mA	Instantaneous current as a root mean square (RMS). The effective value is always positive, because it has no direction.
Active Power	14.056 DPT_Value_Power in W	f32 in W	Instantaneous active power. Active power is the real consumed energy per unit time. It may be positive (during Energy consumption) or negative (during Energy generation). Refer to Figure 24.
Reactive Power	14.056 DPT_Value_Power in Var	f32 in Var	Instantaneous reactive power. Reactive power is the exchanging energy between capacitance and inductance . It can be positive (inductive) or negative (capacitive). See also Figure 24.
Apparent Power	14.056 DPT_Value_Power in VA	f32 in VA	Instantaneous apparent power. Apparent power is the value resulting from active and reactive power. This is always positive. With the apparent power the utilization of resources such as cables or transformers can be assessed.
Power Factor	14.057 DPT_Value_Power_Factor without unit	f32 without unit	Instantaneous power factor. The power factor ($\cos \varphi$) is the ratio of active power to apparent power. The sign is defined in Figure 24.
Spectrum-U	DPT_Harmonics without unit	u08 without unit	Harmonics (0. to 50.) of the voltage . Since the recording of the test series takes a minute, the values correspond to the harmonics one minute ago. When transmitting a complete spectrum, four single messages with each 14 Bytes are transmitted. In them all the harmonics of a voltage are coded as follows: The first byte corresponds to an index of a harmonic; i.e. an integer number between 0 and 50. The second byte is the amount of the harmonic corresponding to the index from the first byte. The following 12 bytes correspond to the amount of the next 12 harmonics. Thus, the values of 13 harmonics are transmitted in a 14-byte message. To exploit the range of values of a byte in an optimal way, the values of a byte are again encoded. For decoding, a byte needs to be interpreted as a positive integer x (i.e. between 0 and 255) and according to the formula $V = 10^{\left(\frac{x-253}{80}\right)}$ it has to be converted into a corresponding value V which is the ratio of the corresponding harmonic to the fundamental.
Spectrum-I	DPT_Harmonics without unit		Harmonics (0. to 50.) of the current. Since the recording of the test series takes a minute, the values correspond to the harmonics one minute ago. The coding of messages and the values corresponds to the the spectrum-U

THD-U	8.010 DPT_ Percent_V16 in 0.01 %	s16 in 0.01 %	Instantaneous total harmonic distortion of the voltage. Percentage represents the ratio of the effective value of harmonics to the effective value of the fundamental. It is always positive.
THD-I	8.010 DPT_ Percent_V16 in 0.01 %	s16 in 0.01 %	Instantaneous total harmonic distortion of the current. Percentage represents the ratio of the effective value of harmonics to the effective value of the fundamental. It is always positive.
Unbalanced load	8.010 DPT_ Percent_V16 in 0.01 %	s16 in 0.01 %	Instantaneous unbalanced load in the three-phase system. Percentage describes the ratio of the negative sequence component of the current to the positive sequence component of the current. It is always defined as positive.
Zero current	9.021 DPT_ Value_Curr in mA	f16 in mA	Instantaneous zero current in three-phase system as a root mean square (RMS). It is determined by in-phase addition (vectorial) of the currents of all three channels. For three-phase connection the value corresponds to the current in the neutral conductor.
Active energy counter (balance)	13.010 DPT_ ActiveEnergy in Wh	s32 in Wh	Instantaneous count held by the balancing counter. In this counter the balance of the energy flow is counted. If it is negative, for example, the energy flow in the negative direction of the power count arrow is greater than the energy flow in the positive direction.
Active energy-counter (consumption)	13.010 DPT_ ActiveEnergy in Wh	s32 in Wh	Instantaneous count of the consumption counter. In this counter only the consumed energy, i.e. the energy flow in positive direction of the power count arrow is counted. The value represents the consumed energy and is always greater than or equal to zero.
Active energy counter (generation)	13.010 DPT_ ActiveEnergy in Wh	s32 in Wh	Instantaneous count of the generation counter. In this counter only the generated energy, i.e. the energy flow in negative direction of the power count arrow is counted. The value represents the generated energy and is always less than or equal to zero.
Reactive energy counter	[13.012] DPT_ ReactiveEnergy in Varh	s32 in Varh	Instantaneous count of the reactive energy counter. In this counter the absolute value of the reactive power is counted. The shown value is the absolute value of the reactive power and therefore always positive.
Tariff costs counter (balance)	13.001 DPT_ Value_4_Count in ct	s32 in ct	Currently accounted costs in the corresponding tariff. This value indicates the balance between consumption and generation costs. The value can be positive or negative. If the value is negative, the absolute value corresponds to a compensation.
Tariff costs counter (consumption)	13.001 DPT_ Value_4_Count in ct	s32 in ct	Current costs for the consumed energy in the corresponding tariff.
Tariff costs counter (generation)	13.001 DPT_ Value_4_Count in ct	s32 in ct	Current costs for the generated energy counted in the corresponding tariff. These costs are (at positive tariff-rate) negative and therefore correspond to a compensation. The counter is used to a certain extent for counting the compensation for the generated energy in the corresponding tariff.

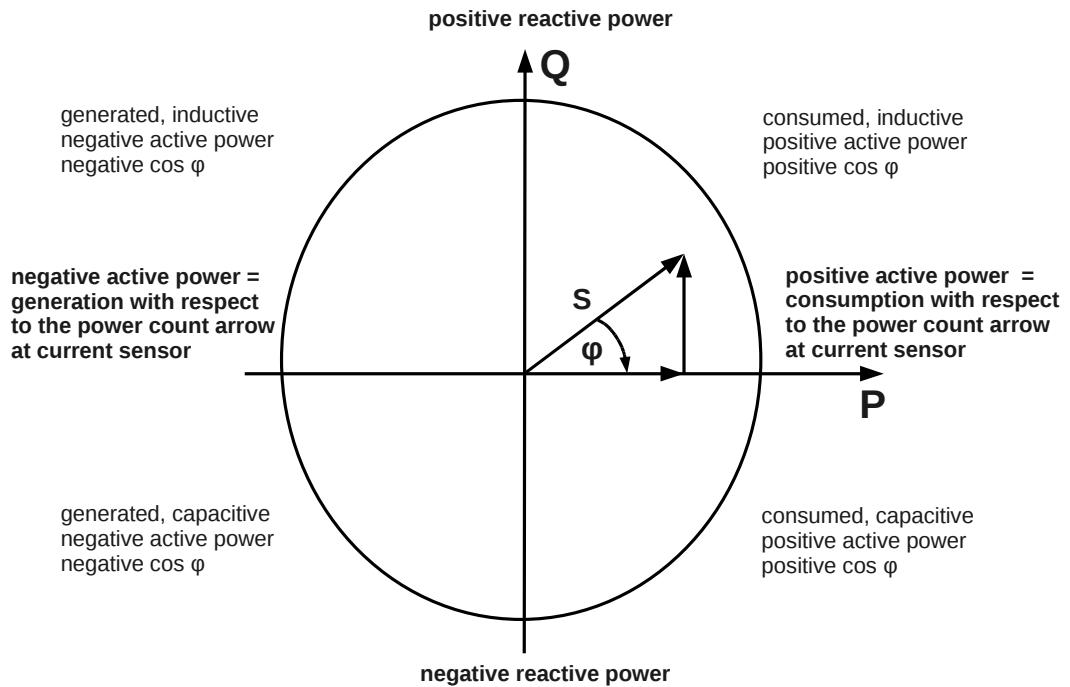

Figure 24: Representation of the counter quadrant

General Function Concepts

Cyclical transmitting

Measured values and counter readings can be transmitted cyclically on the bus. The function is used as for equidistant representation of a measured value on the bus or in a diagram and thus represents a sampling of the measured value.

When activated, the corresponding values are transmitted on the bus in a cycle time, which can also be parametrized by ETS. The first transmission is carried out shortly after a restart of the application. From this moment the value is transmitted cyclically. The transmissions are not synchronized with day-time in this case.

If the cycle time 0 is given in the ETS, the value will never be transmitted cyclically.

Transmit at Change

Measurement values and counter readings can be transmitted on the bus after a change. The function is used for a complete representation of a measurement on the bus or in a diagram. Since the measured values are only transmitted after a change this can be done with a minimal strain of the bus. On the bus a maximum of one change of a measurement value per second can be transmitted.

In the ETS it can be parametrized, at which change the value on the bus is retransmitted. This value is indicated in percentage. The first transmission is always performed shortly after a restart of the application. From this point a new value is transmitted in each case, if the measured value has changed by more than the set percentage value relative to the value last transmitted on the bus. It is independent of whether the value last transmitted has been transmitted due to the function "Transmit cyclically", "Transmit at change" or "Request measured values".

Attention: In the setting "Transmit at change" it is to be noted that the last transmitted measured value can vary from the actual current measurement value by up to the percentage value which is parametrized in the ETS respectively. With the help of the adjustable percentage a suitable compromise between the deviation of the indication from the current measured value and the bus strain can be found.

If in the ETS the percentage is specified to 0% the value will never be transmitted on a change.

Bidirectional Counter

The device can be used as a bidirectional counter and as a balancing counter at the same time. Bidirectional counter are always required when at the measurement point of the counter an energy flow occurs in both directions and in addition the energy flow in one direction is different billed as the energy flow in the opposite direction. This is the case e.g. during the operation of a PV-system in a residential building. If the Smartmeter is installed at the house connection line then the registers for both directions must be used.

For this purpose each energy counter of the Smartmeter (i.e. active energy counter-channel 1, active energy counter-channel 2, active energy counter-channel 3 and active energy counter three-phase) has three registers. One register for the consumption (group object "Active energy counter (consumption)"), one register for the generation (group object "Active energy counter (generation)") and one register for the balance (group object "Active energy counter (balance)"). The register for the consumption only counts, when an energy flow occurs in positive power flow direction. The register for the generation only counts, when an energy flow occurs in negative power flow direction. The register for the balance counts in both cases.

The power arrow direction is determined by the orientation of the current sensors. The power arrow which is glued on the current sensors $\overset{P+}{\rightarrow}$ indicates the positive power arrow direction. Typically the current sensors are mounted so that the power arrow is oriented from the energy source to the energy consumer load. This means that in the example of the installation of the counter at the connection line of the residential home the current sensors are oriented so, that the power arrow shows from the national grid to the consumer loads in the residential home. If energy is currently consumed in the house, then the consumption counter counts in that case. If in the house energy is never generated, the generation counter is always zero. If in the house energy can be generated, e.g. by a PV-facility, then different scenarios are possible:

Scenario	Consumer counter	Generation counter	Consequence
More energy is consumed than generated in the house.	counting	not counting	Energy is charged by the supply rate of the energy provider.
More energy is generated than consumed in the house.	not counting	counting	Energy is charged by the feed-in tariff of the energy provider.
As much as energy is consumed as generated in the house.	not counting	not counting	Nothing is charged.

The "Active energy counter (balance)" also counts in the first both scenarios. For the charge of the energy delivery only the value of the "Active energy counter (consumption)" is used. However, for the charge of the compensation only the value of the "Active energy counter (generation)" is used.

The "Active energy counter (generation)" is by definition always negative, since it is a negative energy flow related to the power count arrow. With this definition it is always :

Active energy counter (balance) = Active energy counter (consumption) + Active energy counter (generation)

Just as the energy counters each tariff costs counter has three registers for consumption, generation and balance. They are treated in the same way, i.e. during an energy consumption the tariff cost counter counts in the group object "Tariff costs counter (consumption)", during an energy generation the tariff cost counter counts in the group object "Tariff costs counter (generation)" and the tariff cost counter in the group object "Tariff costs counter (balance)" always counts.

Thus with regard to the costs separate registers are also used for each count direction. To count a compensation directly in a cost counter, the feed-in tariff in tariff 1 can be specified. In the group object "Tariff costs counter (generation)" for tariff 1 one can directly read the accumulated compensation. In order that the compensation in the counter appears positive, a negative rate (=compensation) has to be specified in the panel for the rate of tariff 1. If also energy delivery costs are to be counted, the delivery rate of the supplier of electric energy can be indicated in tariff 2. In the group object "Tariff costs counter (consumption)" for tariff 2 the accumulated current costs can be read directly. The group object "Tariff costs counter (consumption)" for tariff

2 can be ignored in this case.

Intermediate Counter

Intermediate counter are used to display energy consumptions and energy costs on the bus or in a diagram.

An intermediate counter accumulates (sums) in each case a selectable count value over a configurable time interval. This counter value may be an energy consumption, an energy generation, an energy cost value or a compensation for electricity fed into the grid. The counter value and the counting interval are configured in the ETS. The counting interval of the intermediate counter is thereby synchronized with the daytime, so that, for example, an accumulation of energy values for one hour always starts on the hour.

In detail an intermediate counter operates as follows:

After restarting the application the selected counter value is accumulated (summed) in the current value of the intermediate counter, that is group object "Current value". This accumulation is carried out up to the first interval limit. Since the interval limits are synchronized with the daytime, one time has to be transmitted to the corresponding group object "time" of the Smartmeter (i.e. once after the restart of the application). To do this automatically, the function "Request time and date after bus voltage recovery" can be used.

Attention: If the time is not transmitted to the Smartmeter, the interval limits cannot be detected and the function of the intermediate counter (unless a manual trigger is used, see section below) can not be used.

Once an interval limit is reached, the accumulated counter value is written from the group object "Current value" into the group object "previous value". Thereafter the counter in the group object "Current value" is reset to zero and the accumulation for the next interval starts again. If the function "Transmit counter value before resetting" is activated, then at the interval limit the counter value of the last count interval in the group object "previous value" is transmitted on the bus. This feature allows for example the energy consumption of the last count interval in the group object "previous value" to be transmitted on the bus at the end of each count interval. This value can then be used to show the energy consumption over one day.

The intermediate counter additionally offers the option to set a count interval with a trigger. Thus, it can be used without time. The function is activated by selecting of "By trigger object" in the parameter count interval. As a trigger object the group object "Reset counters" is used. If in this case the value "ON" is transmitted to the group object then this has the same effect as the reaching of the interval limit in the case above. Thus, for example, it is possible to start a consumption measurement by pressing a key button. By re-pressing the key button the energy consumption, which is measured between the two manual operations, is transmitted on the bus.

Tariff Costs Counter

Tariff costs counters allow a representation of energy costs and energy yields on the bus or in a diagram.

In contrast to the energy counters, which count energy in Wh, the tariff cost counters count the energy costs in cent. Therefore the energy costs and accordingly energy yields have to be indicated in 0.01ct/kWh. These costs and yields are deposited in up to three tariffs, which for each tariff a rate and a time frame can be specified. Furthermore each tariff has three group objects for tariff costs counter wherein in each case the costs for the active energy counter (balance) - three-phase, active energy counter (consumption) - three-phase and active energy counter (generation) - three-phase are counted. It should be noted that only the costs for three-phase can be counted. The cost for the consumption in a single phase, for example, can not be calculated in the Smartmeter.

A tariff costs counter counts each if the tariff is currently active and also the underlying (i.e. either for balance, consumption or generation) three-phase energy counter counts. Due to the set time frame for a tariff it can be determined, if it is currently active. It is also possible that several tariffs are active at the same time. Then they count parallel.

To count positive yields, a negative rate can be specified. In this case the active energy counter (generation) - three-phase, which always contains, by definition, a negative value, is multiplied by a negative rate. The result is a positive yield which represents for example the yield of a PV-

system.

Attention: If a tariff time switch is parametrized for a tariff and the time has not been transmitted to the Smartmeter then the time frames for the tariffs can not be detected. In this case the tariff is never active.

Tariffs can also be activated by trigger objects. The function is activated in the parameter "Tariff changeover" by selecting "via triggering objects". As trigger objects the group objects Trigger (Tariff start)" and "Trigger (Tariff stop)" can be used. If in this case the value "ON" is transmitted to the group object "Trigger (Tariff start)", then the tariff is active. By transmitting the value "ON" to the group object "Trigger (Tariff stop)" the tariff is deactivated again. In connection with the limit value of the intermediate counter for example the costs of a volume tariff can be found. So tariff 1 (low level tariff) can be stopped when a limit value for the three-phase energy counter (consumption) is exceeded and tariff 2 (high level tariff) can be started. With the help of a second threshold which has to be set to 0Wh tariff 2 can be stopped and tariff 1 can be reactivated. With this configuration the two intermediate counter finally only have to be reset at that time at which the volume will be newly "refreshed". This can be done by a manual trigger.

In addition to the triggering of tariffs with the trigger objects the tariff can also be selected via the group object "Tariff changeover". Thereby "By trigger objects" has to be selected also in the parameter "Tariff change". Henceforward by transmitting the values 1, 2 or 3 the same tariff that is tariff 1, tariff 2 or tariff 3 can be activated. If a tariff is enabled by these functions, then the other both tariffs are disabled.

If the tariff selection by triggering objects is enabled then also the parameter "Tariff after bus voltage recovery" is important. Here it can be parametrized which tariff is valid after restarting an application. When selecting "as before" the device activates the same tariffs as last before restarting.

If there is no tariff switching, the parameter "Tariff changeover" can be selected "always active". Then this tariff is always active and time is also not required. It is also possible to parametrize two or three tariffs as always active. Then the current delivery costs can be counted in tariff counter of tariff 1 and the compensation of a PV-system can be counted in tariff counter of tariff 2. For this purpose the electricity rate must be specified in tariff 1 and the compensation has to be specified in tariff 2.

Furthermore the device offers the option to adopt the rate of a tariff from the bus via the group object "Rate (0.01 ct/kWh)". With this possibility the electricity rate can be easily adjusted via the bus in case of a electricity rate change.

Preset of a Counter

Each counter can be preset with an energy value or rate. Thus, a count of the Smartmeter can be matched with an existing counter. This allows easy control of the existing counter.

To preset a count only the "Writing"-flag of the corresponding group object of the counter has to be set. Thereafter the counter can be rewritten via messages from the ETS. The written value are given in Wh (not kWh). If necessary the "Writing"-flag of the corresponding group object can then be removed again.

Message of limit values

In the application limits can be set for different measurement values. When these limits are exceeded or fallen below corresponding messages are triggered on the bus. With this method overloads, over voltages, under voltages, voltage drops, consumption peaks but also critical values related to the grid quality can be reported on the bus. These messages can be used for example for alarm messages or directly to initiate appropriate counteractions.

If a limit value is exceeded, the value 1 is transmitted to the corresponding group object "Limit message". However, if the limit value is fallen below the value 0 will be transmitted to the same group object. The limit values are usually specified as absolute values. However, in the case of currents and powers the limit values are indicated as percentages with respect to a reference value. Thus, alarm messages such as "Alarm when exceeding 90% of the maximum allowable current" can be parametrized literally. The value of the "maximum allowable current" has to be parametrized in the parameter "Reference current for limit values" of the tab "Measurement". It is advisable that each of the backup value is used as a reference current with which the cables are

secures at the measurement point of the Smartmeter. That means during the installation of the Smartmeter for a 35A main fuse the reference value would be parametrized to 35A. The reference value for the power limit is also determined by this parameter.

The reference value for a single-phase power limit is determined by the formula "Reference current x 230", the reference value for a three-phase power limit is determined by the formula "Reference current x 230 x 3". This means a parameter value of 7 would correspond to a reference current of 35A, a single-phase reference power of 8050W and a three-phase reference output of 24150W.

For the limit values of active and reactive power a hysteresis can also be set. This prevents a flood of messages during a fluctuation of a measured value around the limit value (With limits without hysteresis at most one message per second is transmitted at the bus in extreme cases). Also the hysteresis is indicated in percent with respect to the above-mentioned reference value.

The setting of a hysteresis has the effect, that the value 1 is not transmitted to the limit value until the measured value exceeds the value "parametrized limit value + 1/2 x parametrized hysteresis value". Similarly, the value 0 is not transmitted until the measured value falls below the value " parametrized limit value - 1/2 x parametrized hysteresis value".

Attention: If negative limit values are used at the power limits then by definition the values for the hysteresis have also to be selected to be negative. In addition it should be noted that in case of a negative limit value the value 1 is transmitted if the measured value exceeds the limit as an absolute value. Similarly the value of 0 is transmitted if the measures value drops below the limit as an absolute value.

Furthermore, limit values for counters can be realized. However, this is only possible for the so-called intermediate counter. As described in section "Intermediate Counter" an intermediate counter has two group objects, of which the so called object "Energy counter-previous value" always include the counter value of the last counting interval whereas the group object "Energy counter-current value" is reset at the end of the counting interval and then again starts to count. Within the counting interval, therefore, only the counter of the group object "Energy counter-current value" counts. Hence the threshold is applied to this group object. Just as the object "Energy counter-current value" also the object "Limit Message" of the intermediate counter is reset at the end of the interval. This allows a transmission of the value 1 to the group object "Limit message" in each count interval when a limit is exceeded, regardless of whether the limit has been exceeded in the previous count interval.

The limits for the intermediate counters and the powers can also be changed by the bus via corresponding group objects. Thus, a limit value, parametrized in the ETS can be overwritten by that value, which has been transmitted to the group object. This allows, for example, the individual setting of a limit value depending on specific conditions, for example in the daytime a higher limit value can be used than in the night.

Recording on the SD card

Using the SD card measured data can be recorded. By the ETS the recording mode and the recording interval can be parametrized. The recording modes are as follows:

Name	Recording parameters
Energy consumption	Over the time interval accumulated active energy for each channel and the three-phase system (respectively active energy (balance), active energy (consumption), active energy (generation)), over the time interval accumulated reactive energy for the three-phase system
Current-/Voltage monitoring	Voltage, Current, THD-U and THD-I for each channel, Number of the voltage and current peaks detected in the time interval for each channel during the recording interval
All measured values without harmonics	All measured values from the mode "Energy consumption" and "Current-/Voltage monitoring" and additional unbalanced load, line frequency and zero current.
Harmonics	Harmonics of voltage and current for each channel.

By default the recording mode is set to "All measurements without harmonics". The recording interval can be configured in steps 1min, 5min, 15min, 1h, 12h, and 24h.

After starting the application the recording to the SD-card starts. During the recording start a new text file in csv-format is created on the SD-card, respectively. The file name is automatically

generated from the recording mode and the recording day. A new recording file on the SD-card is created for each day. In the first two lines of the log file it is a legend with name and unit for the respective measured value of the corresponding column. the following lines contain the recorded data. Each line starts with a time stamp indicating the time of recording of the measured data record. The values in the data set represent the measured values in the previous recording interval.(i.e.time to time stamp).

The recorded values are to be distinguished as follows:

Measurement value	Interpretation	Names in the legend
Active energy	Accumulated active energy over the interval	Ebal_Chx, Econ_Chx, Egen_Chx respective Ebal_3ph, Econ_3ph, Egen_3ph for three-phase values
Reactive energy	Accumulated amount of reactive energy over the interval	Ereact_3ph
Voltage, Current	Averaged rms over the interval	U_Chx, I_Chx
Number of voltage peaks, Number of current peaks	Sum of all detected voltage or current peaks. If a voltage value briefly exceeds the value of 650V, then this event is interpreted as a transient voltage peak. If a current value briefly exceeds the value of 140A then this event is interpreted as a transient current peak.	NoUp_Chx, Nolp_Chx
Total harmonic distortion of voltage (THD-U), total harmonic distortion of current (THD-I)	Averaged measured value over the interval. Percentage is the effective value of the harmonics with respect to the effective value of the fundamental	ThdU_Chx, ThdI_Chx
Active power, reactive power	Averaged measured value over the interval.	P_Chx, Q_Chx bzw. P_3ph, Q_3ph for three-phase values
Power factor	Averaged measured value over the interval.	Pf_Chx
Unbalanced load	Averaged measured value over the interval. Percentage represents the current of the negative sequence system with respect to the current of positive sequence system	UnbalLoad_3ph
Power frequency	Averaged measured value over the interval.	Freq_Ch1
Zero current	Averaged measured value over the interval.	I0_3ph
Harmonics of voltage	Averaged measured value over the interval. Percentage represents the effective value of the corresponding harmonics with respect to the effective value of the fundamental	UhY_Chx, where Y is the index of the harmonics. It is between 0 (dc.) and 50.
Harmonics of current	Averaged measured value over the interval. Percentage represents the effective value of the corresponding harmonics with respect to the effective value of the fundamental	IhY_Chx, where Y is the index of the harmonics. It is between 0 (dc.) and 50.

Here “_Chx” stands for the channels _Ch1, _Ch2 and Ch3, respectively. A log file can be opened with a standard spreadsheet program. The presentation in a spreadsheet program, for example, for the mode "Current-/Voltage monitoring" can look like this:

#Timestamp	U_Ch1	U_Ch2	U_Ch3	NoUp_Ch1	NoUp_Ch2	NoUp_Ch3	ThdU_Ch1	ThdU_Ch2
# [ISO 8601]	[V]	[V]	[V]	[]	[]	[]	[%]	[%]
2015-03-12-18:15:00	228.72	229.72	228.02	0	1	2	99.60	0.12
2015-03-12-18:30:00	228.52	229.52	228.12	0	0	0	99.60	0.1
2015-03-12-18:45:00	228.62	229.72	228.02	1	0	1	99.60	0.06

Thereby the correct time and the correct date is shown in the time stamp, once (i.e. once after the restart of the application) a time has to be transmitted to the group object “Time” and a date has to be transmitted to the group object “Date” of the Smartmeter. To do this automatically after

a restart of the application the function "Request time and date after bus voltage recovery" can be used. If a time and a date has been transmitted to the Smartmeter then the recording is made each synced with the time of the day, that means at a recording interval of 15 minutes the recording is carried out in each case to the minute XX:00 (= every hour), to the minute XX:15, to the minute XX:30 and to the minute XX:45.

If no time has been transferred to the Smartmeter by bus, then the clock is set to 00:00 when the application starts and the first recording is performed after the elapse of the first recording interval.

If at a time of recording no SD card is inserted then the recording data are lost for this time, since the recording is not additionally buffered. If at the start of the application no SD card is inserted, then the recording do not start until the first time of recording after insertion of the SD card.

Attention: When the Smartmeter writes data to the SD card, the "POWER / SD-WRITE" LED lights up red while writing. To prevent loss of data on the SD card, the SD card may not be removed during the write operations.

Adjusting the real-time clock without bus access

At a Smartmeter with RT option, the internal time of the smart meter can also be adjusted without a KNX bus using only an SD card. Usually, the adjustment of the time is only necessary after a few years, since the deviation of the internal time to the actual time increases only by a maximum of one minute per year. The changeover from winter to summer time or from summer to winter time is automatic, so there is no need to intervene manually. Likewise, leap years are automatically taken into account in the date.

To readjust the time with an SD card, you must first create a text file with the date and time on it. This text file must be created with the file name "DATETIME.TXT" (uppercase letters must be used!). Then the file must be saved using a simple text editor, such as Editor or Wordpad. The time to be set in the form of the time stamp, which is also used in the recording files, must now be entered into the file. That For example, the text "2016-05-10-14:23:05" for May 10, 2016 and the time of day of 14:23 and 5 seconds. To ensure that the time is interpreted correctly by the Smartmeter, you must ensure that the time is entered exactly according to the specified pattern and that no characters other than numbers, hyphen and colon are used. The SD card must now be inserted into the Smartmeter during operation. As soon as the SD card is inserted, the time stored on the SD card is taken over. The correct acceptance of the time is confirmed by the yellow "POWER / SD-WRITE" LED lighting up for 2 seconds and then turning green again. To set the time to the second with this method, the text file must specify a time in the future. The SD card must then be inserted into the Smartmeter at exactly the specified time. If the time has been taken over correctly, the file "DATETIME.TXT" will also be deleted automatically.

A smart meter with the RT option has an internal CR2032 lithium coin cell to maintain the clock during power outages. The built-in battery lasts about 7 to 10 years if the device was not disconnected from the 24V power supply for more than one year. If, after 7 to 10 years, there is a large deviation in the time (more than 10 minutes), the internal battery must be replaced. The exchange of the battery is only possible by opening the housing. To do this, the housing cover must first be removed. This is snapped on the lower housing part and can be levered with a screwdriver on the two provided notches on the cover. If the cover is removed, then the two housing halves can be pulled apart. Finally, the lithium button cell in the battery clip can be replaced.

Parameter

Note: Depending on the configuration, some settings may not be available. They are not shown in the ETS in these cases.

General

Under the "General" tab the following settings can be made:

1.1.1 KNXSmartmeter > General

General	Transmission delay after bus voltage recovery (s)	2
Measurement	Transmission delay when sending intermediate counter values (s)	2
Measurement - channel 1	Request time and date after bus voltage recovery	<input checked="" type="radio"/> Yes <input type="radio"/> No
Measurement - channel 2	Value of group object 'Request Time'	<input checked="" type="radio"/> 0 <input type="radio"/> 1
Measurement - channel 3	Transmit group object 'In operation' (s)	0
Measurement - three-phase	Value of group object 'In operation'	<input checked="" type="radio"/> 0 <input type="radio"/> 1
Energy counter/Tariff cost cou...		
Energy counter - channel 1		
Energy counter - channel 2		
Energy counter - channel 3		
Energy counter - three-phase		
Tariff cost counter - three-p...		
Tariff		

Figure 25: General settings

Description of the parameters

Name	Options	Description
Transmission delay after bus voltage recovery (s)	[2-255]	All messages that are transmitted after a bus voltage recovery are delayed for this time. The device can thus be configured so that transmission of objects after the bus voltage recovery do not overload the bus.
Transmission delay when sending intermediate counter values(s)	2-255	All messages to be transmitted before the reset of the intermediate counter are delayed for this time. Thus the device can be configured so that transmission of counts of the counter do not overload the bus.
Request time and date after bus voltage recovery	[Yes / No]	After the bus voltage recovery the time and date can be obtained from the bus.
Value of group object "Request time"	[0 / 1]	The value of the group object for time requesting can be parametrized.
Transmit group object "In operation" (s)	[0,1...6535, 0 = never transmit]	The group object "In operation" can be transmitted cyclically with the parametrized interval.
Value of group object "In operation"	[0 / 1]	The value of the group object "In operation" must be specified.

Measurement

Under the tab "Measurement the following settings can be made:

1.1.1 KNXSmartmeter > Measurement

General	Reference current for limit values (x5A)	17
Measurement	Release frequency Measurement	<input checked="" type="radio"/> Yes <input type="radio"/> No
Measurement - channel 1	Transmit frequency cyclically (x10s)	0
Measurement - channel 2	Transmit frequency at change (x0.1Hz)	0
Measurement - channel 3	SD card recording mode	All measurements without harmonics
Measurement - three-phase	SD card recording interval	15min
Energy counter/Tariff cost cou...	Release group object 'Request measured values'	<input checked="" type="radio"/> Yes <input type="radio"/> No
Energy counter - channel 1	Request measured values	0
Energy counter - three-phase	Release group object 'Request power values'	<input checked="" type="radio"/> Yes <input type="radio"/> No
Tariff cost counter - three-p...	Request power values	0
Intermediate counter 1	Release channel 1	<input checked="" type="radio"/> Yes <input type="radio"/> No
Tariff	Release channel 2	<input checked="" type="radio"/> Yes <input type="radio"/> No
	Release channel 3	<input checked="" type="radio"/> Yes <input type="radio"/> No
	Release three-phase values	<input checked="" type="radio"/> Yes <input type="radio"/> No

Figure 26: Parameter Measurement

Description of the parameters:

Name	Options	Description
Reference current for limit values (x5A)	[1,2 ... 134]	All current limits assigning in percentage are based on the values set here. Power limits (or the corresponding hysteresis values) in percentage are related to 230 x reference current. Three-phase power limits (or the corresponding hysteresis values) are related to 3 x 230 x reference current. Example: When setting the value 17 the reference current is 17 x 5A = 85A. A power limit of the channel 1 of 50% would then trigger at 9.975W (85A x 230V x 50% = 9.975W).
Release frequency Measurement	[Yes / No]	Release of parameters and group objects for the measurement of the frequency (measured from the voltage of channel 1)
Transmit frequency cyclically (x10s)	[0,1,2...17280, 0 = not transmit cyclically]	The group object with the measured frequency is transmitted cyclically at intervals of the parametrized value.
Transmit frequency at change (x0.1 Hz)	[0..650, 0 = not transmit when changing]	The group object with the measured frequency is transmitted on a change to the configured value.
SD card recording mode	[Energy consumption/ Current-,Voltage monitoring/ All measurement values without harmonics/ Harmonics]	Mode indicates which measurements are recorded on the SD card. See section Recording on the SD card for the description of the recording modes.
SD card recording interval	[- / 1min / 5min / 15min / 1h / 12h / 24h, "-" = never recording]	In these intervals measured values incl. time stamp are recorded on the SD card. As with the intermediate counters the record timings are synchronized with the time. See section Recording on the SD card for details on the recording interval.

Name	Options	Description
Release group object "Request measured values"	[Yes / No]	The group object "Request measured values" is released.
Request measured values	[0 / 1 / 0 or 1]	The transmission of the measured values are requested with a group object which has the value parametrized here. When requesting all measured values for current, voltage, THD-U, THD-I, Spectrum-I, Spectrum-U, frequency and zero current are transmitted on the bus, in which the function "Transmit cyclically" is enabled.
Release group object "Request power values"	[Yes / No]	The group object "Request power values" can be released.
Request power values	[0 / 1 / 0 or 1]	The transmission of the measured values are requested with a group object which has the value parametrized here. When requesting all measured values for active power, reactive power, apparent power, power factor and unbalanced load are transmitted on the bus, in which the function "Transmit cyclically" is enabled.
Release channel 1	[Yes / No]	Release of the parameter and group objects for measurements of channel 1.
Release channel 2	[Yes / No]	Release of the parameter and group objects for measurements of channel 2.
Release channel 3	[Yes / No]	Release of the parameter and group objects for measurements of channel 3.
Release three-phase values	[Yes / No]	Release of the parameter and group objects for measurements of three-phase values.

Settings under the tab „Measurement channel 1,2 or 3 (Part 1)“:

General	Transmit power and voltage measurements cyclically	<input checked="" type="radio"/> Yes <input type="radio"/> No
Measurement	Transmit values cyclically (x10s)	<input type="text" value="0"/>
Measurement - channel 1	Transmit active power cyclically	<input checked="" type="radio"/> Yes <input type="radio"/> No
Measurement - channel 2	Transmit apparent power cyclically	<input checked="" type="radio"/> Yes <input type="radio"/> No
Measurement - channel 3	Transmit reactive power cyclically	<input checked="" type="radio"/> Yes <input type="radio"/> No
Measurement - three-phase	Transmit voltage cyclically	<input checked="" type="radio"/> Yes <input type="radio"/> No
Energy counter/Tariff cost coun...	Transmit power-, voltage- and current measurements at change	<input checked="" type="radio"/> Yes <input type="radio"/> No
Tariff	Transmit measured values at change (in % of current measured value)	<input type="text" value="0"/>
	Transmit active power at change	<input checked="" type="radio"/> Yes <input type="radio"/> No
	Transmit apparent power at change	<input checked="" type="radio"/> Yes <input type="radio"/> No
	Transmit reactive power at change	<input checked="" type="radio"/> Yes <input type="radio"/> No
	Transmit voltage at change	<input checked="" type="radio"/> Yes <input type="radio"/> No
	Transmit current at change	<input checked="" type="radio"/> Yes <input type="radio"/> No
	Message at limit value (active power)	<input checked="" type="radio"/> Yes <input type="radio"/> No
	Adopt limit value from bus	<input checked="" type="radio"/> flighty <input type="radio"/> permanent
	Limit value (x0.1%)	<input type="text" value="0"/>
	Hysteresis (x0.1%)	<input type="text" value="0"/>
	Message at limit value (voltage)	<input checked="" type="radio"/> Yes <input type="radio"/> No
	Limit value (V)	<input type="text" value="0"/>

Figure 27: Parameter measurement channel 1 (Part 1)

Description of the parameters:

Name	Options	Description
Transmit power and voltage measurements cyclically	[Yes/ No]	The parameters for cyclical transmission are hereby released.
Transmit measurements cyclically (x10s)	[0,1,2...17280, 0 = not transmit cyclically]	The group objects with the measured values for active-, reactive-, apparent power and voltage of the channel 1, 2 or 3 are transmitted cyclically at intervals of the parametrized value.
Transmit active power cyclically	[Yes/ No]	It is set whether the measured value for the above-mentioned cycle time is transmitted.
Transmit apparent power cyclically	[Yes/ No]	It is set whether the measured value for the above-mentioned cycle time is transmitted.
Transmit reactive power cyclically	[Yes/ No]	It is set whether the measured value for the above-mentioned cycle time is transmitted.

Name	Options	Description
Transmit voltage cyclically	[Yes/ No]	It is set whether the measured value for the above-mentioned cycle time is transmitted.
Transmit power, voltage and current measurements at change.	[Yes/ No]	The parameters for transmission at change are hereby released.
Transmit measured values at change (in % of the current measured value).	[0, 1, ... 255]	The group objects with the measured values for active-, reactive-, apparent power and voltage of the channel 1, 2 or 3 are transmitted on a change to the configured value.
Transmit active power at change	[Yes/ No]	It is set whether the measured value is transmitted when changing the above-mentioned percentage value.
Transmit apparent power at change	[Yes/ No]	It is set whether the measured value is transmitted when changing the above-mentioned percentage value.
Transmit reactive power at change	[Yes/ No]	It is set whether the measured value is transmitted when changing the above-mentioned percentage value.
Transmit voltage at change	[Yes/ No]	It is set whether the measured value is transmitted when changing the above-mentioned percentage value.
Transmit current at change	[Yes/ No]	It is set whether the measured value is transmitted when changing the above-mentioned percentage value.
Message at limit value (active power)	[Yes/ No]	When exceeding or falling below a threshold value of the active power of channel 1, 2 or 3, a group object is transmitted. Release of the limit parameters and the group object See also section Message of limit values.
Adopt limit value from bus	[flighty / permanent]	The limit overtaken by the bus will either be valid only until the next reset or override the configured value permanently.
Limit value(x0.1%)	[-1000 ... -1, 0, +1 ... +1000]	Limit value of the active power of channel 1, 2 or 3. The limit is specified here as a percentage of the reference power (=230 x reference current). In case of negative limits it should be noted that the value 1 is transmitted when the measured value exceeds the limit by absolute value. Similarly the value 0 is transmitted when the measurement value drops below the limit by the absolute value. See also section Message of limit values
Hysteresis (x0.1%)	[-1000 ... -1, 0, +1 ... +1000]	The limit value of the active power of channel 1, 2 or 3 has to be exceeded or fallen below at least by the half value of the hysteresis, so that the group object is transmitted. The value is given in percent of the reference power. (=230V x reference current). If the threshold is selected to be negative, then the value for the hysteresis has also by definition to be selected as negative.
Message at limit value (voltage)	[Yes/ No]	When exceeding or falling below a limit value of the voltage on channel 1, 2 or 3, a group object is transmitted. Release of a limit parameter and the group object
Limit value (V)	[0, 1 ... 800]	Limit value of the voltage of the channel.

Settings under the tab „Measurement channel 1,2 or 3 (Part 2)“:

Energy counter/Tariff cost coun...	Message at voltage failure (voltage)	<input checked="" type="radio"/> Yes <input type="radio"/> No
Tariff	Message at transient voltage peak	<input checked="" type="radio"/> Yes <input type="radio"/> No
	Transmit current and power quality measurements cyclically	<input checked="" type="radio"/> Yes <input type="radio"/> No
	Transmit values cyclically (x10s)	<input type="text" value="0"/>
	Transmit current cyclically	<input checked="" type="radio"/> Yes <input type="radio"/> No
	Transmit power factor cyclically	<input checked="" type="radio"/> Yes <input type="radio"/> No
	Transmit THD-U cyclically	<input checked="" type="radio"/> Yes <input type="radio"/> No
	Transmit THD-I cyclically	<input checked="" type="radio"/> Yes <input type="radio"/> No
	Transmit spectrum U cyclically	<input checked="" type="radio"/> Yes <input type="radio"/> No
	Transmit spectrum I cyclically	<input checked="" type="radio"/> Yes <input type="radio"/> No
	Message at limit value (current)	<input checked="" type="radio"/> Yes <input type="radio"/> No
	Limit value (x0.1%)	<input type="text" value="0"/>
	Message at transient current peak	<input checked="" type="radio"/> Yes <input type="radio"/> No
	Message at limit value (THD-U)	<input checked="" type="radio"/> Yes <input type="radio"/> No
	Limit value (x0.1%)	<input type="text" value="0"/>
	Message at limit value (THD-I)	<input checked="" type="radio"/> Yes <input type="radio"/> No
	Limit value (x0.1%)	<input type="text" value="0"/>

Figure 28: Parameter Measurement channel 1 (Part 2)

Description of the parameters

Name	Options	Description
Message at voltage failure (voltage)	[Yes / No]	At voltage outage (applies when $V_{ac} < 60V_{rms}$) of the channel a group object is transmitted. If $60V_{rms}$ is exceeded, 0 is transmitted, If $60V_{rms}$ is fallen below , 1 is transmitted. Release of the group object.
Message at transient voltage peak	[Yes / No]	In case of an appearance of a transient voltage spike with a peak value min. 650V a group object is transmitted. Release of the group object. Transient voltages (operations) are not predictable (at random) and of a limited duration. They are not repeated periodically and their shape can not be clearly predict. Transient voltage spikes can be caused e.g. by lightning strikes or by triggering a fuse or a circuit breaker.
Transmit current and power quality measurements cyclically	[Yes / No]	The parameter for cyclically transmission are hereby released.

Name	Options	Description
Transmit measurements cyclically (x10s)	[0,1,2...17280]	The group objects with the below-mentioned measured values of channel 1, 2 or 3 are transmitted cyclically in temporal distance of the parametrized values
Transmit current cyclically	[Yes / No]	It is set whether the measured value is transmitted at the above-mentioned cycle time.
Transmit power factor cyclically	[Yes / No]	It is set whether the measured value is transmitted at the above-mentioned cycle time.
Transmit THD-U cyclically	[Yes / No]	It is set whether the measured value is transmitted at the above-mentioned cycle time.
Transmit THD-I cyclically	[Yes / No]	It is set whether the measured value is transmitted at the above-mentioned cycle time.
Transmit spectrum U cyclically	[Yes / No]	It is set whether the measured value is transmitted at the above-mentioned cycle time.
Transmit spectrum I cyclically	[Yes / No]	It is set whether the measured value is transmitted at the above-mentioned cycle time.
Message at limit value (current)	[Yes / No]	When exceeding or falling below a threshold value of the current on channel 1, 2 or 3 a group object is transmitted. Release of the limit parameter and the group object.
Limit value (x0.1%)	[0, 1, 2 ... 1000]	Limit value of the current on channel 1, 2 or 3, which shall be monitored. The limit is given here as a percentage of the reference current. See also section Message of limit values.
Message at transient current peak	[Yes / No]	In case of an appearance of a transient current spike with a peak value min. 140A a group object is transmitted. If 140A is exceeded 1 is transmitted. Release of the group object. Transient currents (operations) are not predictable (at random) and of a limited duration. They are not repeated periodically and their shape can not be clearly predict. Transient current spikes can be caused e.g. by lightning strikes or switching a large capacity or a large transformer (Inrush).
Message at limit value (THD-U)	[Yes / No]	In case of exceeding or falling below of a limit value for THD-U on channel 1, 2 or 3, a group object is transmitted. Release of the limit parameter and the group object.
Limit value (x0.1%)	[0, 1, ... 255]	Limit value of THD-U on channel 1, 2 or 3.
Message at limit value (THD-I)	[Yes / No]	In case of exceeding or falling below of a limit value for THD-I on channel 1, 2 or 3, a group object is transmitted. Release of the limit parameter and the group object.
Limit value(x0.1%)	[0, 1, ... 255]	Limit value of THD-I on channel 1, 2 or 3.

Settings under the tab “Measurement three-phase values “ (Part 1):

1.1.1.1 KNXSmartmeter > Measurement - three-phase

General	Transmit three-phase values cyclically	<input checked="" type="radio"/> Yes <input type="radio"/> No
Measurement	Transmit values cyclically (x10s)	1
Measurement - channel 1	Transmit active power cyclically	<input checked="" type="radio"/> Yes <input type="radio"/> No
Measurement - channel 2	Transmit apparent power cyclically	<input checked="" type="radio"/> Yes <input type="radio"/> No
Measurement - channel 3	Transmit reactive power cyclically	<input type="radio"/> Yes <input checked="" type="radio"/> No
Measurement - three-phase	Transmit zero current cyclically	<input type="radio"/> Yes <input checked="" type="radio"/> No
Energy counter/Tariff cost cou...	Transmit unbalanced load cyclically	<input type="radio"/> Yes <input checked="" type="radio"/> No
Energy counter - channel 1	Transmit power and current measurements at change	<input checked="" type="radio"/> Yes <input type="radio"/> No
Energy counter - three-phase	Transmit measured values at change (in % of current measured value)	0
Tariff cost counter - three-p...	Transmit active power at change	<input checked="" type="radio"/> Yes <input type="radio"/> No
Intermediate counter 1	Transmit apparent power at change	<input checked="" type="radio"/> Yes <input type="radio"/> No
Tariff	Transmit reactive power at change	<input type="radio"/> Yes <input checked="" type="radio"/> No
	Transmit zero current at change	<input type="radio"/> Yes <input checked="" type="radio"/> No

Figure 29: Parameter Measurement three-phase values (Part 1)

Description of parameters:

Name	Options	Description
Transmit three-phase values cyclically	[Yes / No]	The parameters for cyclically transmission are hereby released.
Transmit values cyclically (x10s)	[0,1,2...17280, 0 = not transmit cyclically]	The group objects with the measured values of the three-phase variables are transmitted cyclically at intervals of the parametrized value.
Transmit active power cyclically	[Yes / No]	It is set whether the measured value for the above-mentioned cycle time is transmitted.
Transmit apparent power cyclically	[Yes / No]	It is set whether the measured value for the above-mentioned cycle time is transmitted.
Transmit reactive power cyclically	[Yes / No]	It is set whether the measured value for the above-mentioned cycle time is transmitted.
Transmit zero current cyclically	[Yes / No]	It is set whether the measured value for the above-mentioned cycle time is transmitted.
Transmit unbalanced load cyclically	[Yes / No]	It is set whether the measured value for the above-mentioned cycle time is transmitted.
Transmit power and current measurements at change	[Yes / No]	The parameters for transmission at change are hereby released.
Transmit measured values at change (in % of current measured value)	[0, 1, ... 255]	The group objects with the measured values for active, reactive apparent power and zero current are transmitted on a change to the configured value.
Transmit active power at change	[Yes / No]	It is set whether the measured value is transmitted when changing the above-mentioned percentage value.
Transmit apparent power at change	[Yes / No]	It is set whether the measured value is transmitted when changing the above-mentioned percentage value.
Transmit reactive power at change	[Yes / No]	It is set whether the measured value is transmitted when changing the above-mentioned percentage value.
Transmit zero current at change	[Yes / No]	It is set whether the measured value is transmitted when changing the above-mentioned percentage value.

Settings under the tab “Measurement three-phase values “ (Part 2):

Message at limit value (three-phase-active power)	<input checked="" type="radio"/> Yes <input type="radio"/> No
Adopt limit value from bus	<input checked="" type="radio"/> flighty <input type="radio"/> permanent
Limit value (x0.1%)	<input type="text" value="0"/>
Hysteresis (x0.1%)	<input type="text" value="0"/>
Message at limit value (reactive power)	<input checked="" type="radio"/> Yes <input type="radio"/> No
Limit value (x0.1%)	<input type="text" value="0"/>
Hysteresis (x0.1%)	<input type="text" value="1"/>
Message at limit value (unbalanced load)	<input checked="" type="radio"/> Yes <input type="radio"/> No
Limit value (%)	<input type="text" value="0"/>
Message at limit value (zero current)	<input checked="" type="radio"/> Yes <input type="radio"/> No
Limit value (x0.1%)	<input type="text" value="0"/>

Figure 30: Parameter Measurement three-phase values (Part 2)

Description of parameters:

Name	Options	Description
Message at limit value (three-phase active power)	[Yes / No]	When exceeding or falling below a threshold value of the three phase active power a group object is transmitted. Release of the limit parameter and the group object.
Adopt limit value from bus	[flighty / permanent]	The limit adopted by the bus will either be valid only until the next reset or override the configured value permanently.
Limit value (x0.1%)	[-1000 ... -1, 0, +1 ... +1000]	Limit of the three phase active power. The limit here is specified as a percentage of the three phase reference power (= 3 x 230 x reference current). In case of negative limits it should be noted that the value 1 is transmitted when the measured value exceeds the limit as an absolute value. Similarly the value 0 is transmitted when the measured value drops below the limit as an absolute value. See. also section Message of limit values
Hysteresis (x0.1%)	[-1000 ... -1, 0, +1 ... +1000]	The limit of the three-phase active power has to be exceeded or fallen below by at least half the value of the hysteresis so that the group object is transmitted. The limit here is specified as a percentage of the three-phase reference power (= 3 x 230 V x reference current). If the threshold is selected to be negative, then also the value for the hysteresis has to be selected by definition as negative.
Message at limit value (reactive power)	[Yes / No]	When exceeding or falling below a threshold value of the three-phase reactive power a group object is transmitted. Release of the limit parameter and of the group object.

Name	Options	Description
Limit value (x0.1%)	[-1000 ... -1, 0, +1 ... +1000]	Limit of the three-phase reactive power. The limit here is specified as a percentage of the three phase reference power (= 3 x 230 x reference current). In case of negative limits it should be noted that the value 1 is transmitted when the measured value exceeds the limit as an absolute value. Similarly the value 0 is transmitted when the measured value drops below the limit as an absolute value. See also section Message of limit values
Hysteresis (x0.1%)	[-1000 ... -1, 0, +1 ... +1000]	The limit of the three-phase active power has to be exceeded or fallen below by at least half the value of the hysteresis so that the group object is transmitted. The limit here is specified as a percentage of the three-phase reference power (= 3 x 230 V x reference current). If the threshold is selected to be negative, then also the value for the hysteresis has to be selected by definition as negative.
Message at limit value (unbalanced load)	[Yes / No]	When exceeding or falling below the limit value for the unbalanced load a group object is transmitted. Release of the limit parameter and of the group object.
Limit value (%)	[0, 1, ... 100]	Limit for the unbalanced load.
Message at limit value (zero current)	[Yes / No]	When exceeding or falling below the limit value for the zero current a group object can be transmitted. Release of the limit parameter and the group object..
Limit value (x0.1%)	[-1000 ... -1, 0, +1 ... +1000]	Limit value for the zero current. The limit is given here as a percentage of the reference current. See also section Message of limit values

Energy counter / Tariff cost counter

Under the tab “Energy counter / tariff counter” the following settings can be made:

General	Release energy counter - channel 1	<input checked="" type="radio"/> Yes <input type="radio"/> No
Measurement	Release energy counter - channel 2	<input checked="" type="radio"/> Yes <input type="radio"/> No
Measurement - channel 1	Release energy counter - channel 3	<input checked="" type="radio"/> Yes <input type="radio"/> No
Measurement - channel 2	Release energy counter - three-phase	<input checked="" type="radio"/> Yes <input type="radio"/> No
Measurement - channel 3	Release tariff cost counter - three-phase	<input checked="" type="radio"/> Yes <input type="radio"/> No
Measurement - three-phase	Release tariff cost counter 1	<input checked="" type="radio"/> Yes <input type="radio"/> No
Energy counter/Tariff cost co...	Release tariff cost counter 2	<input checked="" type="radio"/> Yes <input type="radio"/> No
Energy counter - channel 1	Release tariff cost counter 3	<input checked="" type="radio"/> Yes <input type="radio"/> No
Energy counter - channel 2	Release intermediate counter 1	<input checked="" type="radio"/> Yes <input type="radio"/> No
Energy counter - channel 3	Release intermediate counter 2	<input checked="" type="radio"/> Yes <input type="radio"/> No
Energy counter - three-phase	Release intermediate counter 3	<input checked="" type="radio"/> Yes <input type="radio"/> No
Tariff cost counter - three-p...	Release intermediate counter 4	<input checked="" type="radio"/> Yes <input type="radio"/> No
Intermediate counter 1	Release intermediate counter 5	<input checked="" type="radio"/> Yes <input type="radio"/> No
Intermediate counter 2	Release intermediate counter 6	<input checked="" type="radio"/> Yes <input type="radio"/> No
Intermediate counter 3		
Intermediate counter 4		
Intermediate counter 5		

Figure 31: Parameter Energy counter

Description of the parameters:

Name	Options	Description
Release energy counter - channel 1	[Yes / No]	The release of the parameters and group objects for the energy counter of channel 1. For the operation of energy counters see also section Bidirectional Counter.
Release energy counter - channel 2	[Yes / No]	The release of the parameters and group objects for the energy counter of channel 2 For the operation of energy counters see also section Bidirectional Counter.
Release energy counter - channel 3	[Yes / No]	The release of the parameters and group objects for the energy counter of channel 3. For the operation of energy counters see also section Bidirectional Counter.
Release energy counter - three-phase	[Yes / No]	The release of the parameters and group objects for the groups "Energy counter - three-phase" and "Tariff cost counter - three-phase values". For the operation of energy counters see also section Bidirectional Counter.
Release tariff cost counter - three-phase	[Yes / No]	The release of the parameters for the groups "Tariff cost counter - three-phase" and the parameter "Tariff cost counter - 1, 2, 3". For the operation of tariff cost counters see also section Tariff Costs Counter.
Release tariff counter 1	[Yes / No]	The group objects and the parameters for tariff cost counter tariff 1 (balance), tariff cost counter tariff 1 (consumption), tariff cost counter tariff 1 (generation) are hereby released.
Release tariff counter 2	[Yes / No]	The group objects and the parameters for tariff cost counter tariff 2 (balance), tariff cost counter tariff 2 (consumption), tariff cost counter tariff 2 (generation) are hereby released.
Release tariff counter 3	[Yes / No]	The group objects and the parameters for tariff cost counter tariff 3 (balance), tariff cost counter tariff 3 (consumption), tariff cost counter tariff 3 (generation) are hereby released.
Release intermediate counter 1	[Yes / No]	The release of the parameters and group objects for the group "Intermediate counter 1".
Release intermediate counter 2	[Yes / No]	The release of the parameters and group objects for the group "Intermediate counter 2".
Release intermediate counter 3	[Yes / No]	The release of the parameters and group objects for the group "Intermediate counter 3".
Release intermediate counter 4	[Yes / No]	The release of the parameters and group objects for the group "Intermediate counter 4".
Release intermediate counter 5	[Yes / No]	The release of the parameters and group objects for the group "Intermediate counter 5".
Release intermediate counter 6	[Yes / No]	The release of the parameters and group objects for the group "Intermediate counter 6".

Settings under the tab “Energy counter channel 1, 2 or 3”:

General	Transmit counter values cyclically	<input checked="" type="radio"/> Yes <input type="radio"/> No
Measurement	Transmit counter values cyclically (x10s)	1
Measurement - channel 1	Transmit cyclically active energy counter (balance)	<input checked="" type="radio"/> Yes <input type="radio"/> No
Measurement - channel 2	Transmit cyclically active energy counter (consumption)	<input checked="" type="radio"/> Yes <input type="radio"/> No
Measurement - channel 3	Transmit cyclically active energy counter (generation)	<input checked="" type="radio"/> Yes <input type="radio"/> No
Measurement - three-phase	Transmit counter values at change	<input checked="" type="radio"/> Yes <input type="radio"/> No
Energy counter/Tariff cost cou...	Transmit counter values at change (in % of current measured value)	1
Energy counter - channel 1	Transmit at change active energy counter (balance)	<input checked="" type="radio"/> Yes <input type="radio"/> No
Energy counter - channel 2	Transmit at change active energy counter (consumption)	<input checked="" type="radio"/> Yes <input type="radio"/> No
Energy counter - channel 3	Transmit at change active energy counter (generation)	<input type="radio"/> Yes <input checked="" type="radio"/> No
Energy counter - three-phase	Counter after ETS download	<input checked="" type="radio"/> no reaction <input type="radio"/> reset
Tariff cost counter - three-p...	Release group object "Reset counter values of channel 1"	<input checked="" type="radio"/> Yes <input type="radio"/> No
Intermediate counter 1		
Intermediate counter 2		
Intermediate counter 3		
Intermediate counter 4		

Figure 32: Parameter Energy counter channel 1

Description of the parameters:

Name	Options	Description
Transmit counter values cyclically	[Yes / No]	The parameters for cyclically transmission are hereby released.
Transmit counter values cyclically (x10s)	[0,1,2...17280, 0 = not transmit cyclically]	The group objects for the below-mentioned counter values are transmitted cyclically at intervals of the parametrized value.
Transmit cyclically active energy counter (balance)	[Yes / No]	It is set, whether the counter value is transmitted at above-mentioned cycle time
Transmit cyclically active energy counter (consumption)	[Yes / No]	It is set, whether the counter value is transmitted at above-mentioned cycle time
Transmit cyclically active energy counter (generation)	[Yes / No]	It is set, whether the counter value is transmitted at above-mentioned cycle time
Transmit counter values at change	[Yes / No]	The parameter for transmission and change are hereby released.
Transmit counter values at change (in % of current measured value)	[0, 1, ... 255, 0 = no transmission at change]	The group objects for the below-mentioned counter values are transmitted at change to the configured value.
Transmit at change active energy counter (balance)	[Yes / No]	It is set whether the counter value is transmitted at change of the above-mentioned percentage value.
Transmit at change active energy counter (consumption)	[Yes / No]	It is set whether the counter value is transmitted at change of the above-mentioned percentage value.
Transmit at change active energy counter (generation)	[Yes / No]	It is set whether the counter value is transmitted at change of the above-mentioned percentage value.
Counter after ETS download	[no reaction / reset]	It is set whether the counters are reset after an ETS download.
Release group object "Reset counter values of channel 1 (channel 2 or channel 3)	[Yes / No]	The group object "Reset counters 1, 2 or 3" is released.If ON is transmitted to this object then the three counter values for balancing energy counter, consumption counter and generation counter for channel 1, 2 or 3 are reset.

Settings under the tab “Energy counter three-phase values”:

General	Transmit counter values cyclically	<input checked="" type="radio"/> Yes <input type="radio"/> No
Measurement	Transmit counter values cyclically (x10s)	1
Measurement - channel 1	Transmit cyclically active energy counter (balance)	<input checked="" type="radio"/> Yes <input type="radio"/> No
Measurement - channel 2	Transmit cyclically active energy counter (consumption)	<input type="radio"/> Yes <input checked="" type="radio"/> No
Measurement - channel 3	Transmit cyclically active energy counter (generation)	<input type="radio"/> Yes <input checked="" type="radio"/> No
Energy counter/Tariff cost cou...	Transmit reactive energy counter cyclically	<input type="radio"/> Yes <input checked="" type="radio"/> No
Energy counter - channel 1	Transmit counter values at change	<input checked="" type="radio"/> Yes <input type="radio"/> No
Energy counter - channel 2	Transmit counter values at change (in % of current measured value)	1
Energy counter - channel 3	Transmit at change active energy counter (balance)	<input checked="" type="radio"/> Yes <input type="radio"/> No
Energy counter - three-ph...	Transmit at change active energy counter (consumption)	<input checked="" type="radio"/> Yes <input type="radio"/> No
Tariff cost counter - three-p...	Transmit at change active energy counter (generation)	<input checked="" type="radio"/> Yes <input type="radio"/> No
Intermediate counter 1	Transmit reactive energy counter at change	<input checked="" type="radio"/> Yes <input type="radio"/> No
Intermediate counter 2	Counter after ETS download	<input checked="" type="radio"/> no reaction <input type="radio"/> reset
Intermediate counter 3	Release group object "Reset counter values"	<input checked="" type="radio"/> Yes <input type="radio"/> No
Intermediate counter 4		
Intermediate counter 5		
Intermediate counter 6		

Figure 33: Parameter Energy counter three-phase values

Description of the parameters:

Name	Options	Description
Transmit counter values cyclically	[Yes / No]	The parameters for cyclical transmission are hereby released.
Transmit counter values cyclically (x10s)	[0, 1, 2... 17280, 0 = not transmit cyclically]	The group objects for the below-mentioned counter values are transmitted cyclically at intervals of the configured value.
Transmit cyclically active energy counter (balance)	[Yes / No]	It is set whether the counter value of the above-mentioned cycle time is transmitted.
Transmit cyclically active energy counter (consumption)	[Yes / No]	It is set whether the counter value of the above-mentioned cycle time is transmitted.
Transmit cyclically active energy counter (generation)	[Yes / No]	It is set whether the counter value of the above-mentioned cycle time is transmitted.
Transmit reactive energy counter cyclically	[Yes / No]	It is set whether the counter value of the above-mentioned cycle time is transmitted.
Transmit counter values at change	[Yes / No]	The parameters for transmission at are hereby released.
Transmit counter values at change (in % of current measured value)	[0, 1, ... 255, 0 = no transmission at change]	The group objects with the below-mentioned counter values are transmitted at change to the parametrized value.
Transmit at change active energy counter (balance)	[Yes / No]	It is set whether the counter value is transmitted at change of the above-mentioned percentage value.
Transmit at change active energy counter (consumption)	[Yes / No]	It is set whether the counter value is transmitted at change of the above-mentioned percentage value.
Transmit at change active energy counter (generation)	[Yes / No]	It is set whether the counter value is transmitted at change of the above-mentioned percentage value.

Name	Options	Description
Transmit reactive energy counter at change	[Yes / No]	It is set whether the counter value is transmitted at change of the above-mentioned percentage value.
Counter after ETS download	[no reaction / reset]	It is set whether the counter values of the three-phase register are reset after an ETS download.
Release group object "Reset counter values"	[Yes / No]	The group object "Reset of counter values" is released. If an ON is transmitted to this object, then the balancing active energy counter, consumption counter and generation counter are reset for the three-phase registers.

Under the tab "Tariff cost counter" the following settings can be made:

General	Transmit tariff cost counter cyclically	<input checked="" type="radio"/> Yes <input type="radio"/> No
Measurement	Transmit cyclically (x10s) tariff cost counter	0
Measurement - channel 1	Transmit cyclically tariff cost counter 1 (balance)	<input checked="" type="radio"/> Yes <input type="radio"/> No
Measurement - channel 2	Transmit cyclically tariff cost counter 1 (con.)	<input checked="" type="radio"/> Yes <input type="radio"/> No
Measurement - channel 3	Transmit cyclically tariff cost counter 1 (generation)	<input type="radio"/> Yes <input checked="" type="radio"/> No
Measurement - three-phase	Transmit cyclically tariff cost counter 2 (balance)	<input type="radio"/> Yes <input checked="" type="radio"/> No
Energy counter/Tariff cost cou...	Transmit cyclically tariff cost counter 2 (con.)	<input type="radio"/> Yes <input checked="" type="radio"/> No
Energy counter - channel 1	Transmit cyclically tariff cost counter 2 (generation)	<input type="radio"/> Yes <input checked="" type="radio"/> No
Energy counter - channel 2	Transmit cyclically tariff cost counter 3 (balance)	<input type="radio"/> Yes <input checked="" type="radio"/> No
Energy counter - channel 3	Transmit cyclically tariff cost counter 3 (con.)	<input type="radio"/> Yes <input checked="" type="radio"/> No
Energy counter - three-phase	Transmit cyclically tariff cost counter 3 (generation)	<input type="radio"/> Yes <input checked="" type="radio"/> No
Tariff cost counter - three-...	Release group object "Reset Tariff counter values 1"	<input checked="" type="radio"/> Yes <input type="radio"/> No
Intermediate counter 1	Release group object "Reset Tariff counter values 2"	<input type="radio"/> Yes <input checked="" type="radio"/> No
Intermediate counter 2	Release group object "Reset Tariff counter values 3"	<input type="radio"/> Yes <input checked="" type="radio"/> No
Intermediate counter 3		
Intermediate counter 4		
Intermediate counter 5		
Intermediate counter 6		
Tariff		

Figure 34: Parameter Tariff cost counter

Description of the parameters:

Name	Options	Description
Transmit tariff cost counter cyclically	[Yes / No]	The parameters for cyclical transmission are hereby released
Transmit cyclically (x10s) tariff cost counter	[0 to 172800, 0 = not transmit cyclically]	The group objects with the values of the balancing tariff cost counters are transmitted cyclically at intervals of the configured value.
Transmit cyclically tariff cost counter 1 (balance)	[Yes / No]	It is set whether the measured value for the above-mentioned cycle time is transmitted.
Transmit cyclically tariff cost counter 1 (con.)	[Yes / No]	It is set whether the measured value for the above-mentioned cycle time is transmitted.
Transmit cyclically tariff cost counter 1 (generation)	[Yes / No]	It is set whether the measured value for the above-mentioned cycle time is transmitted.
Transmit cyclically tariff cost counter 2 (balance)	[Yes / No]	It is set whether the measured value for the above-mentioned cycle time is transmitted.
Transmit cyclically tariff cost counter 2 (con.)	[Yes / No]	It is set whether the measured value for the above-mentioned cycle time is transmitted.

Name	Options	Description
Transmit cyclically tariff cost counter 2 (generation)	[Yes / No]	It is set whether the measured value for the above-mentioned cycle time is transmitted.
Transmit cyclically tariff cost counter 3 (balance)	[Yes / No]	It is set whether the measured value for the above-mentioned cycle time is transmitted.
Transmit cyclically tariff cost counter 3 (con.)	[Yes / No]	It is set whether the measured value for the above-mentioned cycle time is transmitted.
Transmit cyclically tariff cost counter 3 (generation)	[Yes / No]	It is set whether the measured value for the above-mentioned cycle time is transmitted.
Release group object "Reset Tariff counter values 1"	[Yes / No]	The group object "Reset Tariff counter values 1" is released.
Release group object "Reset Tariff counter values 2"	[Yes / No]	The group object "Reset Tariff counter values 2" is released.
Release group object "Reset Tariff counter values 3"	[Yes / No]	The group object "Reset Tariff counter values 3" is released.

Settings under the tab “Intermediate counter 1-6”:

General	Input counter value of intermediate counter	Active energy counter (balance) - channel 1
Measurement	Count interval	1min
Measurement - channel 1	Transmit counter value before resetting	<input checked="" type="radio"/> Yes <input type="radio"/> No
Measurement - channel 2	Transmit counter values cyclically (x10s)	0
Measurement - channel 3	Message at limit value	<input checked="" type="radio"/> Yes <input type="radio"/> No
Energy counter/Tariff cost cou...	Adopt limit value from bus	<input checked="" type="radio"/> flighty <input type="radio"/> permanent
Energy counter - channel 1	Limit value (Wh)	0
Energy counter - channel 2		
Energy counter - channel 3		
Energy counter - three-phase		
Tariff cost counter - three-p...		
Intermediate counter 1		

Figure 35: Parameter Intermediate counter 1

Description of the parameters:

Name	Options	Description
Input counter value of intermediate counter	[Active energy counter (balance) - channel 1 / Active energy counter (consumption) - channel 1 / Active energy counter (generation) - channel 1 / Active energy counter (balance) - channel 2 / Active energy counter (consumption) - channel 2 / Active energy counter (generation) - channel 2 / Active energy counter (balance) - channel 3 / Active energy counter (consumption) - channel 3 / Active energy counter (generation) - channel 3 / Active energy counter (balance) - three-phase / Active energy counter (consumption) - three-phase / Active energy counter (generation) - three-phase / Tariff cost counter (balance) - tariff 1 / Tariff cost counter (consumption) - tariff 1 / Tariff cost counter (generation) - tariff 1 / Tariff cost counter (balance) - tariff 2 / Tariff cost counter (consumption) - tariff 2 / Tariff cost counter (generation) - tariff 2 / Tariff cost counter (balance) - tariff 3 / Tariff cost counter (consumption) - tariff 3 / Tariff cost counter (generation) - tariff 3 /	Here the counted value can be selected which is counted in the intermediate counter. An intermediate counter is a counter that automatically resets after a certain time. The final counter value before resetting is written to the group object “Intermediate counter - previous value” and then, if parametrized, is transmitted on the bus. See also section Intermediate Counter.

Name	Options	Description
Count interval	[1min, 5min, 10min, 15min, 1h, 12h, 24h, 1 week, via trigger object]	The count interval can be selected here. After the selected time the intermediate counter is reset. Before resetting the current intermediate counter reading is copied to the group object of the previous value. The reset time instances of a intermediate counter are synchronized with the time, that is e.g. at time interval of 1 min the counter is reset each when the second indicator of the clock is 0. At 15 min counting interval the counter value is reset corresponding to each synchronized 1/4 hour, that is e.g. 00:00, 00:15, 00:30, 00:45. Note: Since intermediate counters are synchronized with the time, the counter readings only reset at the defined times (and automatically transmitted on the bus), if a time has been transmitted to the group object "time" of the Smartmeter. If the value is set "on trigger object" then the corresponding object is released. If in this case the value ON is transmitted to the trigger group object "Reset counter value", then this has the same effect as reaching the interval limit in the above case.
Transmit counter value before resetting	[Yes / No]	After updating the group object "previous. value" at a count interval limit, this group object is transmitted automatically on the bus. The message is delayed in accordance with the parameter of "General offset when transmitting intermediate counter values"
Transmit counter values cyclically (x10s)	[0,1,2...17280, 0 = not transmit cyclically]	The counter value of the group object "Current value" can be transmitted cyclically.
Message at limit value	[Yes / No]	When exceeding or falling below the limit value of the intermediate counter a group object can be transmitted. Release of the limit parameter and of the group object. See also section Message of limit values
Adopt limit value from bus	[flighty / permanent]	The limit value, adopted by the bus, can either be valid only until the next reset or override the configured value permanently.
Limit value (Wh)	[-32767, -32766, ... -1, 0, 1 ... +32767]	Limit of the intermediate counter. This parameter is only enabled when the counted value of the intermediate counter is an energy counter.
Limit value(Cent)	[-32767, -32766, ... -1, 0, 1 ... +32767]	Limit of the intermediate counter. This parameter is only enabled when the counted value of the intermediate counter is a cost counter.

Tariff

Under the tab "Tariff" the following settings can be made:

General	Release tariff 1	<input checked="" type="radio"/> Yes <input type="radio"/> No
Measurement	Release tariff 2	<input checked="" type="radio"/> Yes <input type="radio"/> No
Measurement - channel 1	Release tariff 3	<input checked="" type="radio"/> Yes <input type="radio"/> No
Measurement - channel 2	Tariff after bus voltage recovery	no tariff
Measurement - channel 3		

Figure 36: Parameter Tariff

Description of the parameters:

Name	Options	Description
Release tariff 1	[Yes / No]	The release of the parameters and group objects for the tariff 1 can be parametrized.
Release tariff 2	[Yes / No]	The release of the parameters and group objects for the tariff 2 can be parametrized.
Release tariff 3	[Yes / No]	The release of the parameters and group objects for the tariff 3 can be parametrized.
Tariff after bus voltage recovery	[no tariff / Tariff 1 / Tariff 2 / Tariff 3 / as before]	The valid tariff after bus voltage recovery or restarting of the application can be parametrized. The setting is effective only for the tariffs, which are controlled "By trigger objects"

Settings under the tab “Tariff 1, 2 or 3”:

Measurement - channel 2	Rate (0.01 ct/kWh)	4
Measurement - channel 3	Adopt rate from bus	<input checked="" type="radio"/> flighty <input type="radio"/> permanent
Measurement - three-phase	Tariff changeover tariff 1	via tariff-time switch
Energy counter/Tariff cost cou...	Start (hour)	0
Energy counter - channel 1	Start (minute)	0
Energy counter - channel 2	Start (weekday)	everyday
Energy counter - channel 3	End (hour)	0
Energy counter - three-phase	End (minute)	0
Tariff cost counter - three-p...	End (weekday)	everyday
Intermediate counter 1		
Intermediate counter 2		

Figure 37: Parameter Tariff 1

Description of the parameters:

Name	Options	Description
Rate (0.01ct/kWh)	[-10000,-9999... +10000]	The kWh rate of tariff 1, 2 or 3 has to be specified.
Adopt rate from bus	[flighty / permanent]	The rate can be overridden by an object. The rate adopted by the bus, can either be valid only until the next reset or override the configured value permanently.
Tariff changeover tariff 1(2 ,3 respectively)	[via tariff-time switch / via triggering objects / always active]	The tariff can be controlled either via the tariff parameters (time) or trigger objects or always be active. If “by trigger object” is selected then the two group objects are enabled. With the value “always active” no tariff switching takes place. See section Tariff Costs Counter
Start (hour)	[0...23]	The hour of the commencement of tariff 1, 2 and 3 ,respectively.
Start (minute)	[0...59]	The minute of the commencement of tariff 1, 2 and 3, respectively.
Start (weekday)	[Mo/Tu/We/Th/Fr/Sa/Su/Weekdays/Weekend/everyday]	The day of commencement of tariff 1, 2 and 3, respectively.
End (hour)	[0...23]	The hour of the end of tariff 1, 2 and 3, respectively.
End (minute)	[0...59]	The minute of the end of tariff 1, 2 and 3, respectively.
End (weekday)	[Mo/Tu/We/Th/Fr/Sa/Su/Weekdays/Weekend/everyday]	The day of the end of tariff 1, 2 and 3, respectively.

Group Objects

Notes:

Depending on the configuration, some objects may not be available. Group objects, which include measured variables, are described in detail in section Measurement quantities.

ID	Name	Object function	Length	Type	Flags
0	General	Power saving mode	1 bit	[1.003] DPT_Enable	CRWT-

The energy sensor can be switched via the KNX bus into the power saving mode. In power saving mode no measurements are performed.

ID	Name	Object function	Length	Type	Flags
1	General	Time	3 Byte	[10.001] DPT_TimeOFDay	C-W-U

This time is used for the intermediate counter, tariff - time switch and the time stamp of the SD card log function. If configured, the Smartmeter automatically requests the time using this group object after restarting the application from the bus.

ID	Name	Object function	Length	Type	Flags
162	General	Date	3 Byte	[11.001] DPT_Date	C-W-U

This date is used for the intermediate counter, the tariff - time switch and the time stamp of the SD card log function. If configured, the Smartmeter automatically requests the date using this group object after restarting the application from the bus.

ID	Name	Object function	Length	Type	Flags
2	General	Request time	1 Bit	[1.002] DPT_Bool	C--T-

The time of the Smartmeter can be requested by an other bus participant from the Smartmeter using this group object.

ID	Name	Object function	Length	Type	Flags
3	General	In operation	1 Bit	[1.002] DPT_Bool	C--T-

This group object can be transmitted cyclically to monitor the operation of the Smartmeter.

ID	Name	Object function	Length	Type	Flags
4	Measurement	Request measurements	1 Bit	[1.002] DPT_Bool	C-W--

Using this group object all measured values can be requested excluding the performance values. At request only the measured values are transmitted, in which the parameter "Transmit cyclically" has been activated.

ID	Name	Object function	Length	Type	Flags
5	Measurement	Request power values	1 Bit	[1.002] DPT_Bool	C-W--

Using this group object all power values can be requested. At request only the power values are transmitted in which "Transmit cyclically" has been activated.

ID	Name	Object function	Length	Type	Flags
6	Measurement	Frequency	4 Byte	[14.033] DPT_Value_Freque ncy	CR-T-

Group object with the last measured power frequency

ID	Name	Object function	Length	Type	Flags
7	Measurement Ch1	Voltage (rms)	2 Byte	[9.020] DPT_Value_Volt	CR-T-

Group object with the most recently determined RMS voltage of channel 1

ID	Name	Object function	Length	Type	Flags
8	Measurement Ch1	Current (rms)	2 Byte	[9.021] DPT_Value_Curr	CR-T-

Group object with the most recently determined RMS current of channel 1

ID	Name	Object function	Length	Type	Flags
9	Measurement Ch1	Active power	4 Byte	[14.056] DPT_Value_Power	CR-T-

Group object with the most recently determined active power of channel 1

ID	Name	Object function	Length	Type	Flags
10	Measurement Ch1	External active power limit	2 Byte	[8.010] DPT_Percent_V16	CRWT-

Limit value of the active power of channel 1. The value read is valid only if this object was written after a reset at least once.

ID	Name	Object function	Length	Type	Flags
11	Measurement Ch1	Active power limit message	1 Bit	[1.002] DPT_Bool	C--T-

Group object, that is transmitted with the value 1 or 0, if the limit of the active power of channel 1 has been exceeded or fallen below.

ID	Name	Object function	Length	Type	Flags
12	Measurement Ch1	Voltage limit message	1 Bit	[1.002] DPT_Bool	C--T-

Group object, that is transmitted with the value 1 or 0, if the limit of the voltage of channel 1 has been exceeded or fallen below.

ID	Name	Object function	Länge	Typ	Flags
13	Measurement Ch1	Voltage failure message	1 Bit	[1.002] DPT_Bool	C--T-

Group object, that is transmitted with the value 1 or 0, if the voltage of channel 1 exceeds or falls below 60Vrms.

ID	Name	Object function	Length	Type	Flags
14	Measurement Ch1	Voltage peak message	1 Bit	[1.002] DPT_Bool	C--T-

Group object that transmits the value 1 if a transient voltage spike greater than 650V is detected at channel 1.

ID	Name	Object function	Length	Type	Flags
15	Measurement Ch1	Current limit message	1 Bit	[1.002] DPT_Bool	C--T-

Group object, that is transmitted with the value 1 or 0, if the limit of the current of channel 1 has been exceeded or fallen below.

ID	Name	Object function	Length	Type	Flags
16	Measurement Ch1	Current peak message	1 Bit	[1.002] DPT_Bool	C--T-

Group object that transmits the value 1 if a transient current spike greater than 140A is detected at channel 1.

ID	Name	Object function	Length	Type	Flags
17	Measurement Ch1	THD-U limit message	1 Bit	[1.002] DPT_Bool	C--T-

Group object, that is transmitted with the value 1 or 0, if the limit of the THD-U of channel 1 has been exceeded or fallen below.

ID	Name	Object function	Length	Type	Flags
18	Measurement Ch1	THD-I limit message	1 Bit	[1.002] DPT_Bool	C--T-

Group object, that is transmitted with the value 1 or 0, if the limit of the THD-I of channel 1 has been exceeded or fallen below.

ID	Name	Object function	Length	Type	Flags
19	Measurement Ch1	Apparent power	4 Byte	[14.056] DPT_Value_Power	CR-T-

Group object with the most recently determined apparent power of the channel1.

ID	Name	Object function	Length	Type	Flags
20	Measurement Ch1	Reactive power	4 Byte	[14.056] DPT_Value_Power	CR-T-

Group object with the most recently determined reactive power of the channel1.

ID	Name	Object function	Length	Type	Flags
21	Measurement Ch1	Power factor	4 Byte	[14.057] DPT_Value_Power _Factor	CR-T-

Group object with the most recently determined power factor of the channel1.

ID	Name	Object function	Length	Type	Flags
22	Measurement Ch1	THD-U	2 Byte	[8.010] DPT_Percent_V16	CR-T-

Group object with the most recently determined THD-U of the channel1.

ID	Name	Object function	Length	Type	Flags
23	Measurement Ch1	THD-I	2 Byte	[8.010] DPT_Percent_V16	CR-T-

Group object with the most recently determined THD-I of the channel1.

ID	Name	Object function	Length	Type	Flags
24	Measurement Ch1	Spectrum-U	14 Byte	New dpt-Type. have not been released yet by KNX	CR-T-

Group object with the most recently determined values of the harmonics of the voltage of the channel 1.
Explanation see section Measurement quantities.

ID	Name	Object function	Length	Type	Flags
25	Measurement Ch1	Spectrum-I	14 Byte	New dpt-Type. have not been released yet by KNX	CR-T-

Group object with the most recently determined values of the harmonics of the current of the channel 1.
Explanation see section Measurement quantities.

ID	Name	Object function	Length	Type	Flags
26	Measurement Ch2	Voltage (rms)	2 Byte	[9.020] DPT_Value_Volt	CR-T-

Group object with the most recently determined rms value of the voltage of the channel 2.

ID	Name	Object function	Length	Type	Flags
27	Measurement Ch2	Current (rms)	2 Byte	[9.021] DPT_Value_Curr	CR-T-

Group object with the most recently determined rms value of the current of the channel 2.

ID	Name	Object function	Length	Type	Flags
28	Measurement Ch2	Active power	4 Byte	[14.056] DPT_Value_Power	CR-T-
Group object with the most recently determined active power of the channel 2.					

ID	Name	Object function	Length	Type	Flags
29	Measurement Ch2	External active power limit	2 Byte	[8.010] DPT_Percent_V16	CRWT-
Limit value of the active power of channel 2. The value read is valid only if this object was written after a reset at least once.					

ID	Name	Object function	Length	Type	Flags
30	Measurement Ch2	Active power limit message	1 Bit	[1.002] DPT_Bool	C--T-
Group object, that is transmitted with the value 1 or 0, if the limit of the active power of channel 2 has been exceeded or fallen below.					

ID	Name	Object function	Length	Type	Flags
31	Measurement Ch2	Voltage limit message	1 Bit	[1.002] DPT_Bool	C--T-
Group object, that is transmitted with the value 1 or 0, if the limit of the voltage of channel 2 has been exceeded or fallen below.					

ID	Name	Object function	Length	Type	Flags
32	Measurement Ch2	Voltage failure message	1 Bit	[1.002] DPT_Bool	C--T-
Group object, that is transmitted with the value 1 or 0, if the voltage at channel 2 exceeds or falls below 60Vrms.					

ID	Name	Object function	Length	Type	Flags
33	Measurement Ch2	Voltage peak message	1 Bit	[1.002] DPT_Bool	C--T-
Group object that transmits the value 1 if at channel 2 a transient voltage spike greater than 650V is detected.					

ID	Name	Object function	Length	Type	Flags
34	Measurement Ch2	Current limit message	1 Bit	[1.002] DPT_Bool	C--T-
Group object, that is transmitted with the value 1 or 0, if the limit of the current of channel 2 has been exceeded or fallen below.					

ID	Name	Object function	Length	Type	Flags
35	Measurement Ch2	Current peak message	1 Bit	[1.002] DPT_Bool	C--T-
Group object that transmits the value 1 if at channel 2 a transient current spike greater than 140A is detected.					

ID	Name	Object function	Length	Type	Flags
36	Measurement Ch2	THD-U limit message	1 Bit	[1.002] DPT_Bool	C--T-
Group object, that is transmitted with the value 1 or 0, if the limit of the THD-U of channel 2 has been exceeded or fallen below.					

ID	Name	Object function	Length	Type	Flags
37	Measurement Ch2	THD-I limit message	1 Bit	[1.002] DPT_Bool	C--T-
Group object, that is transmitted with the value 1 or 0, if the limit of the THD-I of channel 2 has been exceeded or fallen below.					

ID	Name	Object function	Length	Type	Flags
38	Measurement Ch2	Apparent power	4 Byte	[14.056] DPT_Value_Power	CR-T-

Group object with the most recently determined apparent power of the channel 2.

ID	Name	Object function	Length	Type	Flags
39	Measurement Ch2	Reactive power	4 Byte	[14.056] DPT_Value_Power	CR-T-

Group object with the most recently determined reactive power of the channel 2.

ID	Name	Object function	Length	Type	Flags
40	Measurement Ch2	Power factor	4 Byte	[14.057] DPT_Value_Power_Factor	CR-T-

Group object with the most recently determined power factor of the channel 2.

ID	Name	Object function	Length	Type	Flags
41	Measurement Ch2	THD-U	2 Byte	[8.010] DPT_Percent_V16	CR-T-

Group object with the most recently determined THD-U of the channel 2.

ID	Name	Object function	Length	Type	Flags
42	Measurement Ch2	THD-I	2 Byte	[8.010] DPT_Percent_V16	CR-T-

Group object with the most recently determined THD-I of the channel 2.

ID	Name	Object function	Length	Type	Flags
43	Measurement Ch2	Spectrum-U	14 Byte	New dpt-Type. have not been released yet by KNX	CR-T-

Group object with the most recently determined values of the harmonics of the voltage of the channel 2.
Explanation see section Measurement quantities.

ID	Name	Object function	Length	Type	Flags
44	Measurement Ch2	Spectrum-I	14 Byte	New dpt-Type. have not been released yet by KNX	CR-T-

Group object with the most recently determined values of the harmonics of the current of the channel 2.
Explanation see section Measurement quantities.

ID	Name	Object function	Length	Type	Flags
45	Measurement Ch3	Voltage (rms)	2 Byte	[9.020] DPT_Value_Volt	CR-T-

Group object with the most recently determined RMS voltage of the channel 3.

ID	Name	Object function	Length	Type	Flags
46	Measurement Ch3	Current (rms)	2 Byte	[9.021] DPT_Value_Curr	CR-T-

Group object with the most recently determined RMS current of the channel 3.

ID	Name	Object function	Length	Type	Flags
47	Measurement Ch3	Active power	4 Byte	[14.056] DPT_Value_Power	CR-T-

Group object with the most recently active power of the channel 3.

ID	Name	Object function	Length	Type	Flags
48	Measurement Ch3	External active power limit	2 Byte	[8.010] DPT_Percent_V16	CRWT-

Limit value of the active power of channel 3. The value read is valid only if this object was written after a reset at least once.

ID	Name	Object function	Length	Type	Flags
49	Measurement Ch3	Active power limit message	1 Bit	[1.002] DPT_Bool	C--T-

Group object, that is transmitted with the value 1 or 0, if the limit of the active power of channel 3 has been exceeded or fallen below.

ID	Name	Object function	Length	Type	Flags
50	Measurement Ch3	Voltage limit message	1 Bit	[1.002] DPT_Bool	C--T-

Group object, that is transmitted with the value 1 or 0, if the limit of the voltage of channel 3 has been exceeded or fallen below.

ID	Name	Object function	Length	Type	Flags
51	Measurement Ch3	Voltage failure message	1 Bit	[1.002] DPT_Bool	C--T-

Group object, that is transmitted with the value 1 or 0, if the voltage at channel 3 exceeds or falls below 60Vrms.

ID	Name	Object function	Length	Type	Flags
52	Measurement Ch3	Voltage peak message	1 Bit	[1.002] DPT_Bool	C--T-

Group object that transmits the value 1 if at channel 3 a transient voltage spike greater than 650V is detected.

ID	Name	Object function	Length	Type	Flags
53	Measurement Ch3	Current limit message	1 Bit	[1.002] DPT_Bool	C--T-

Group object, that is transmitted with the value 1 or 0, if the limit of the current of channel 3 has been exceeded or fallen below.

ID	Name	Object function	Length	Type	Flags
54	Measurement Ch3	Current peak message	1 Bit	[1.002] DPT_Bool	C--T-

Group object that transmits the value 1 if at channel 3 a transient current spike greater than 140A is detected.

ID	Name	Object function	Length	Type	Flags
55	Measurement Ch3	THD-U limit message	1 Bit	[1.002] DPT_Bool	C--T-

Group object, that is transmitted with the value 1 or 0, if the limit of the THD-U of channel 3 has been exceeded or fallen below.

ID	Name	Object function	Length	Type	Flags
56	Measurement Ch3	THD-I limit message	1 Bit	[1.002] DPT_Bool	C--T-

Group object, that is transmitted with the value 1 or 0, if the limit of the THD-I of channel 3 has been exceeded or fallen below.

ID	Name	Object function	Length	Type	Flags
57	Measurement Ch3	Apparent power	4 Byte	[14.056] DPT_Value_Power	CR-T-

Group object with the most recently determined apparent power of the channel 3.

ID	Name	Object function	Length	Type	Flags
58	Measurement Ch3	Reactive power	4 Byte	[14.056] DPT_Value_Power	CR-T-

Group object with the most recently determined reactive power of the channel 3.

ID	Name	Object function	Length	Type	Flags
59	Measurement Ch3	Power factor	4 Byte	[14.057] DPT_Value_Power_Factor	CR-T-
Group object with the most recently determined power factor of the channel 3.					

ID	Name	Object function	Length	Type	Flags
60	Measurement Ch3	THD-U	2 Byte	[8.010] DPT_Percent_V16	CR-T-
Group object with the most recently determined THD-U of the channel 3.					

ID	Name	Object function	Length	Type	Flags
61	Measurement Ch3	THD-I	2 Byte	[8.010] DPT_Percent_V16	CR-T-
Group object with the most recently determined THD-I of the channel 3.					

ID	Name	Object function	Length	Type	Flags
62	Measurement Ch3	Spectrum-U	14 Byte	New dpt-Type. have not been released yet by KNX	CR-T-
Group object with the most recently determined values of the harmonics of the voltage of the channel 3. Explanation see section Measurement quantities.					

ID	Name	Object function	Length	Type	Flags
63	Measurement Ch3	Spectrum-I	14 Byte	New dpt-Type. have not been released yet by KNX	CR-T-
Group object with the most recently determined values of the harmonics of the current of the channel 3. Explanation see section Measurement quantities.					

ID	Name	Object function	Length	Type	Flags
64	Measurement three-phase	Active power	4 Byte	[14.056] DPT_Value_Power	CR-T-
Group object with the most recently determined three-phase active power					

ID	Name	Object function	Length	Type	Flags
65	Measurement three-phase	External active power limit	2 Byte	[8.010] DPT_Percent_V16	CRWT-
Limit of three-phase active power. The value read is valid only if this object was written after a reset at least once.					

ID	Name	Object function	Length	Type	Flags
66	Measurement three-phase	Active power limit message	1 Bit	[1.002] DPT_Bool	C--T-
Group object that is transmitted with the value 1 or 0, if the limit of the three-phase active power has been exceeded or fallen below.					

ID	Name	Object function	Length	Type	Flags
67	Measurement three-phase	Reactive power	4 Byte	[14.056] DPT_Value_Power	CR-T-
Group object with the most recently determined three-phase reactive power.					

ID	Name	Object function	Length	Type	Flags
68	Measurement three-phase	External reactive power limit	2 Byte	[8.010] DPT_Percent_V16	CRWT-
Limit of three-phase reactive power. The value read is valid only if this object was written after a reset at least once.					

ID	Name	Object function	Length	Type	Flags
69	Measurement three-phase	Reactive power limit message	1 Bit	[1.002] DPT_Bool	CR-T-

Group object that is transmitted with the value 1 or 0, if the limit of the three-phase reactive power has been exceeded or fallen below.

ID	Name	Object function	Length	Type	Flags
70	Measurement three-phase	Apparent power	4 Byte	[14.056] DPT_Value_Power	CR-T-

Group object with the most recently determined three-phase apparent power.

ID	Name	Object function	Length	Type	Flags
71	Measurement three-phase	Unbalanced load	2 Byte	[8.010] DPT_Percent_V16	CR-T-

Group object with the last determined unbalanced load.

ID	Name	Object function	Length	Type	Flags
72	Measurement three-phase	Unbalanced load limit message	1 Bit	[1.002] DPT_Bool	C--T-

Group object that is transmitted with the value 1 or 0, if the limit of the unbalanced load has been exceeded or fallen below.

ID	Name	Object function	Length	Type	Flags
73	Measurement three-phase	Zero current	2 Byte	[9.021] DPT_Value_Curr	CR-T-

Group object with the most recently determined RMS value of zero current.

ID	Name	Object function	Length	Type	Flags
74	Measurement three-phase	Zero current limit message	1 Bit	[1.002] DPT_Bool	C--T-

Group object that is transmitted with the value 1 or 0, if the limit of the zero current has been exceeded or fallen below.

ID	Name	Object function	Length	Type	Flags
75	Energy counter Ch1	Active energy counter (bal.)	4 Byte	[13.010] DPT_ActiveEnergy	CR-T-

Counter value of the balancing active energy counter of channel 1. The counter can be positive or negative. If the value is negative, then the generated power was greater than the consumed energy.

ID	Name	Object function	Length	Type	Flags
76	Energy counter Ch1	Active energy counter (con.)	4 Byte	[13.010] DPT_ActiveEnergy	CR-T-

Counter value of the active energy counter (consumption) of channel 1. This counter value is always positive or 0.

ID	Name	Object function	Length	Type	Flags
77	Energy counter Ch1	Active energy counter (gen.)	4 Byte	[13.010] DPT_ActiveEnergy	CR-T-

Counter value of the active energy counter (generation) of channel 1. This counter value is always negative or 0.

ID	Name	Object function	Length	Type	Flags
78	Energy counter Ch1	Reset counters	1 Bit	[1.017] DPT_Trigger	C-W--

The three counter values (balance, consumption and generation) can be reset to 0 via the group object.

ID	Name	Object function	Length	Type	Flags
79	Energy counter Ch2	Active energy counter (bal.)	4 Byte	[13.010] DPT_ActiveEnergy	CR-T-

Counter value of the balancing active energy counter of channel 2. The counter can be positive or negative. If the value is negative, then the generated power was greater than the consumed energy.

ID	Name	Object function	Length	Type	Flags
80	Energy counter Ch2	Active energy counter (con.)	4 Byte	[13.010] DPT_ActiveEnergy	CR-T-

Counter value of the active energy counter (consumption) of channel 2. This counter value is always positive or 0.

ID	Name	Object function	Length	Type	Flags
81	Energy counter Ch2	Active energy counter (gen.)	4 Byte	[13.010] DPT_ActiveEnergy	CR-T-

Counter value of the active energy counter (generation) of channel 2. This counter value is always negative or 0.

ID	Name	Object function	Length	Type	Flags
82	Energy counter Ch2	Reset counters	1 Bit	[1.017] DPT_Trigger	C-W--

The three counter values (balance, consumption and generation) can be reset to 0 via the group object.

ID	Name	Object function	Length	Type	Flags
83	Energy counter Ch3	Active energy counter (bal.)	4 Byte	[13.010] DPT_ActiveEnergy	CR-T-

Counter value of the balancing active energy counter of channel 3. The counter can be positive or negative. If the value is negative, then the generated power was greater than the consumed energy.

ID	Name	Object function	Length	Type	Flags
84	Energy counter Ch3	Active energy counter (con.)	4 Byte	[13.010] DPT_ActiveEnergy	CR-T-

Counter value of the active energy counter (consumption) of channel 3. This counter value is always positive or 0.

ID	Name	Object function	Length	Type	Flags
85	Energy counter Ch3	Active energy counter (gen.)	4 Byte	[13.010] DPT_ActiveEnergy	CR-T-

Counter value of the active energy counter (generation) of channel 3. This counter value is always negative or 0.

ID	Name	Object function	Length	Type	Flags
86	Energy counter Ch3	Reset counters	1 Bit	[1.017] DPT_Trigger	C-W--

The three counter values (balance, consumption and generation) can be reset to 0 via the group object.

ID	Name	Object function	Length	Type	Flags
87	Energy counter three-phase	Active energy counter (bal.)	4 Byte	[13.010] DPT_ActiveEnergy	CR-T-

Counter value of the balancing active energy counter of the three-phase values. The counter can be positive or negative. If the value is negative, then the generated power was greater than the consumed energy.

ID	Name	Object function	Length	Type	Flags
88	Energy counter three-phase	Active energy counter (con.)	4 Byte	[13.010] DPT_ActiveEnergy	CR-T-

Counter value of the active energy counter (consumption) of the three-phase values. This counter value is always positive or 0.

ID	Name	Object function	Length	Type	Flags
89	Energy counter three-phase	Active energy counter (gen.)	4 Byte	[13.010] DPT_ActiveEnergy	CR-T-

Counter value of the active energy counter (generation) of the three-phase values. This counter value is always negative or 0.

ID	Name	Object function	Length	Type	Flags
90	Energy counter three-phase	Reactive energy counter	4 Byte	[13.010] DPT_ActiveEnergy	CR-T-

Counter value of the reactive energy counter of the three-phase value. The counter value is always positive since only the absolute value of the reactive energy is counted.

ID	Name	Object function	Length	Type	Flags
91	Energy counter three-phase	Reset counters	1 Bit	[1.017] DPT_Trigger	C-W--

The three counter values (balance, consumption, generation and reactive energy counter) can be reset to 0 via the group object.

ID	Name	Object function	Length	Type	Flags
92	Tariff counter 1-three-phase values	Tariff cost counter (balance)	4 Byte	[13.001] (4-Octed Signed)	CR-T-

The object contains the accumulated costs (in Cent) for the tariff 1. They are calculated from the three-phase active energy (balance) counted in tariff 1 and from the rate of tariff 1. The costs can be positive or negative. If the generated energy is greater than the consumed energy, then negative costs arise from that (=compensation).

ID	Name	Object function	Length	Type	Flags
93	Tariff counter 1-three-phase values	Tariff cost counter (con.)	4 Byte	[13.001] DPT_Value_4_Count	CR-T-

The object contains the accumulated costs (in Cent) for the tariff 1. They are calculated from the three-phase active energy (consumption) counted in tariff 1 and from the rate of tariff 1. The costs are always positive or 0.

ID	Name	Object function	Length	Type	Flags
94	Tariff counter 1-three-phase values	Tariff cost counter (gen.)	4 Byte	[13.001] DPT_Value_4_Count	CR-T-

The object contains the accumulated costs (in Cent) for the tariff 1. They are calculated from the three-phase active energy (generation) counted in tariff 1 and from the rate of tariff 1. The costs are always negative (=compensation) or 0.

ID	Name	Object function	Length	Type	Flags
95	Tariff counter 1-three-phase values	Reset counters	1 Bit	[1.017] DPT_Trigger	C-S--

The three tariff counter (balance, consumption and generation) of the tariff 1 can be reset via the group object.

ID	Name	Object function	Length	Type	Flags
96	Tariff counter 2-three-phase values	Tariff cost counter (balance)	4 Byte	[13.001] DPT_Value_4_Count	CR-T-

The object contains the accumulated costs (in Cent) for the tariff 2. They are calculated from the three-phase active energy (balance) counted in tariff 2 and from the rate of tariff 2. The costs can be positive or negative. If the generated energy is greater than the consumed energy, then negative costs arise from that (=compensation).

ID	Name	Object function	Length	Type	Flags
97	Tariff counter 2-three-phase values	Tariff cost counter (con.)	4 Byte	[13.001] DPT_Value_4_Count	CR-T-

The object contains the accumulated costs (in Cent) for the tariff 2. They are calculated from the three-phase active energy (consumption) counted in tariff 2 and from the rate of tariff 2. The costs are always positive or 0.

ID	Name	Object function	Length	Type	Flags
98	Tariff counter 2-three-phase values	Tariff cost counter (gen.)	4 Byte	[13.001] DPT_Value_4_Cou nt	CR-T-
The object contains the accumulated costs (in Cent) for the tariff 2. They are calculated from the three-phase active energy (generation) counted in tariff 2 and from the rate of tariff 2. The costs are always negative (=compensation) or 0.					

ID	Name	Object function	Length	Type	Flags
99	Tariff counter 2-three-phase values	Reset counters	1 Bit	[1.017] DPT_Trigger	C-W--
The three tariff counter (balance, consumption and generation) of the tariff 2 can be reset via the group object.					

ID	Name	Object function	Length	Type	Flags
100	Tariff counter 3-three-phase values	Tariff cost counter (balance)	4 Byte	[13.001] DPT_Value_4_Cou nt	CR-T-
The object contains the accumulated costs (in Cent) for the tariff 3 They are calculated from the three-phase active energy (balance) counted in tariff 3 and from the rate of tariff 3. The costs can be positive or negative. If the generated energy is greater than the consumed energy, then negative costs arise from that (=compensation).					

ID	Name	Object function	Length	Type	Flags
101	Tariff counter 3-three-phase values	Tariff cost counter (con.)	4 Byte	[13.001] DPT_Value_4_Cou nt	CR-T-
The object contains the accumulated costs (in Cent) for the tariff 3. They are calculated from the three-phase active energy (consumption) counted in tariff 3 and from the rate of tariff 3. The costs are always positive or 0.					

ID	Name	Object function	Length	Type	Flags
102	Tariff counter 3-three-phase values	Tariff cost counter (gen.)	4 Byte	[13.001] DPT_Value_4_Cou nt	CR-T-
The object contains the accumulated costs (in Cent) for the tariff 3. They are calculated from the three-phase active energy (generation) counted in tariff 3 and from the rate of tariff 3. The costs are always negative (=compensation) or 0.					

ID	Name	Object function	Length	Type	Flags
103	Tariff counter 3-three-phase values	Reset counters	1 Bit	[1.017] DPT_Trigger	C-W--
The three tariff counter (balance, consumption and generation) of the tariff 3 can be reset via the group object.					

ID	Name	Object function	Length	Type	Flags
104	Intermediate counter 1	Energy counter-current value	4 Byte	[13.010] DPT_ActiveEnergy	CR-T-
The object contains the current energy counter value of the intermediate counter in Wh. The counter value can be positive or negative. The value of the group object is respectively copied after the lapse of the counting interval into the group object "Energy counter - previous value" and then reset.					

ID	Name	Object function	Length	Type	Flags
105	Intermediate counter 1	Energy counter-previous value	4 Byte	[13.010] DPT_ActiveEnergy	CR-T-
The object contains the energy counter value from the previous count interval of the intermediate counter in Wh. If configured, this value is transmitted on the bus after its update. When transmitting the parameter "General - Offset when transmitting of intermediate counter values in (s)" operates as a transmission delay.					

ID	Name	Object function	Length	Type	Flags
106	Intermediate counter 1	Cost counter-current value	4 Byte	[13.001] DPT_Value_4_Cou nt	CR-T-
<p>This object contains the current cost counter value of the intermediate counter in ct. The counter value may be positive or negative. The value of the group object is respectively copied after the lapse of the counting interval into the group object "Cost counter - previous value" and then reset.</p>					

ID	Name	Object function	Length	Type	Flags
107	Intermediate counter 1	Cost counter-previous value.	4 Byte	[[13.001] DPT_Value_4_Cou nt	CR-T-
<p>The object contains the cost counter value from the previous count interval of the intermediate counter in ct. If configured, this value is transmitted on the bus after its update. When transmitting the parameter "General - Offset when transmitting of intermediate counter values in (s)" operates as a transmission delay.</p>					

ID	Name	Object function	Length	Type	Flags
108	Intermediate counter 1	Limit message	1-Bit	[1.002] DPT_Bool	C--T-
<p>Group object that transmits the value 1 or 0, if the limit of the intermediate counter has been exceeded or fallen below.</p>					

ID	Name	Object function	Length	Type	Flags
109	Intermediate counter 1	External energy counter limit	4 Byte	[13.010] DPT_ActiveEnergy	CR-T-
<p>When writing to this object the limit is adopted from the bus. If the parameter "Adopt limit value from the bus" is set on "flighty" then the value adopted by the bus is discarded after the next reset of the intermediate counter. If in contrast the parameter is set on "permanent" then the limit adopted by the bus is permanent.</p>					

ID	Name	Object function	Length	Type	Flags
110	Intermediate counter 1	External cost counter limit	4 Byte	[13.001] DPT_Value_4_Cou nt	CR-T-
<p>When writing to this object the limit is adopted from the bus. If the parameter "Adopt limit value from the bus" is set on "flighty" then the value adopted by the bus is discarded after the next reset of the intermediate counter. If in contrast the parameter is set on "permanent" then the limit adopted by the bus is permanent.</p>					

ID	Name	Object function	Length	Type	Flags
111	Intermediate counter 1	Reset counter value	1-Bit	[1.017] DPT_Trigger	C-W--
<p>If the value 1 is transmitted to this object, then the intermediate counter behaves as it reaches a time interval boundary. The group object is released by the parameter selection "Count interval - by trigger object". See also section Intermediate Counter.</p>					

ID	Name	Object function	Length	Type	Flags
112	Intermediate counter 2	Energy counter-current value	4 Byte	[13.010] DPT_ActiveEnergy	CR-T-
<p>The object contains the current energy counter value of the intermediate counter in Wh. The counter value can be positive or negative. The value of the group object is respectively copied after the lapse of the counting interval into the group object "Energy counter - previous value" and then reset.</p>					

ID	Name	Object function	Length	Type	Flags
113	Intermediate counter 2	Energy counter-previous value.	4 Byte	[13.010] DPT_ActiveEnergy	CR-T-
<p>The object contains the energy counter value from the previous count interval of the intermediate counter in Wh. If configured, this value is transmitted on the bus after its update. When transmitting the parameter "General - Offset when transmitting of intermediate counter values in (s)" operates as a transmission delay.</p>					

ID	Name	Object function	Length	Type	Flags
114	Intermediate counter 2	Cost counter-current value	4 Byte	[13.001] DPT_Value_4_Cou nt	CR-T-

This object contains the current cost counter value of the intermediate counter in ct. The counter value may be positive or negative. The value of the group object is respectively copied after the lapse of the counting interval into the group object "Cost counter - previous value" and then reset.

ID	Name	Object function	Length	Type	Flags
115	Intermediate counter 2	Cost counter-previous value.	4 Byte	[[13.001] DPT_Value_4_Cou nt	CR-T-

The object contains the cost counter value from the previous count interval of the intermediate counter in ct. If configured, this value is transmitted on the bus after its update. When transmitting the parameter "General - Offset when transmitting of intermediate counter values in (s)" operates as a transmission delay.

ID	Name	Object function	Length	Type	Flags
116	Intermediate counter 2	Limit message	1-Bit	[1.002] DPT_Bool	C--T-

Group object that transmits the value 1 or 0, if the limit of the intermediate counter has been exceeded or fallen below.

ID	Name	Object function	Length	Type	Flags
117	Intermediate counter 2	External energy counter limit	4 Byte	[13.010] DPT_ActiveEnergy	CR-T-

When writing to this object the limit is adopted from the bus. If the parameter "Adopt limit value from the bus" is set on "flighty" then the value adopted by the bus is discarded after the next reset of the intermediate counter. If in contrast the parameter is set on "permanent" then the limit adopted by the bus is permanent.

ID	Name	Object function	Length	Type	Flags
118	Intermediate counter 2	External cost counter limit	4 Byte	[13.001] DPT_Value_4_Cou nt	CR-T-

When writing to this object the limit is adopted from the bus. If the parameter "Adopt limit value from the bus" is set on "flighty" then the value adopted by the bus is discarded after the next reset of the intermediate counter. If in contrast the parameter is set on "permanent" then the limit adopted by the bus is permanent.

ID	Name	Object function	Length	Type	Flags
119	Intermediate counter 2	Reset counter value	1-Bit	[1.017] DPT_Trigger	C-W--

If the value 1 is transmitted to this object, then the intermediate counter behaves as it reaches a time interval boundary. The group object is released by the parameter selection "Count interval - by trigger object". See also section Intermediate Counter.

ID	Name	Object function	Length	Type	Flags
120	Intermediate counter 3	Energy counter-current value	4 Byte	[13.010] DPT_ActiveEnergy	CR-T-

The object contains the current energy counter value of the intermediate counter in Wh. The counter value can be positive or negative. The value of the group object is respectively copied after the lapse of the counting interval into the group object "Energy counter - previous value" and then reset.

ID	Name	Object function	Length	Type	Flags
121	Intermediate counter 3	Energy counter-previous value.	4 Byte	[13.010] DPT_ActiveEnergy	CR-T-

The object contains the energy counter value from the previous count interval of the intermediate counter in Wh. If configured, this value is transmitted on the bus after its update. When transmitting the parameter "General - Offset when transmitting of intermediate counter values in (s)" operates as a transmission delay.

ID	Name	Object function	Length	Type	Flags
122	Intermediate counter 3	Cost counter-current value	4 Byte	[13.001] DPT_Value_4_Cou nt	CR-T-
This object contains the current cost counter value of the intermediate counter in ct. The counter value may be positive or negative. The value of the group object is respectively copied after the lapse of the counting interval into the group object "Cost counter - previous value" and then reset.					

ID	Name	Object function	Length	Type	Flags
123	Intermediate counter 3	Cost counter-previous value.	4 Byte	[[13.001] DPT_Value_4_Cou nt	CR-T-
The object contains the cost counter value from the previous count interval of the intermediate counter in ct. If configured, this value is transmitted on the bus after its update. When transmitting the parameter "General - Offset when transmitting of intermediate counter values in (s)" operates as a transmission delay.					

ID	Name	Object function	Length	Type	Flags
124	Intermediate counter 3	Limit message	1-Bit	[1.002] DPT_Bool	C--T-
Group object that transmits the value 1 or 0, if the limit of the intermediate counter has been exceeded or fallen below.					

ID	Name	Object function	Length	Type	Flags
125	Intermediate counter 3	External energy counter limit	4 Byte	[13.010] DPT_ActiveEnergy	CR-T-
When writing to this object the limit is adopted from the bus. If the parameter "Adopt limit value from the bus" is set on "flighty" then the value adopted by the bus is discarded after the next reset of the intermediate counter. If in contrast the parameter is set on "permanent" then the limit adopted by the bus is permanent.					

ID	Name	Object function	Length	Type	Flags
126	Intermediate counter 3	External cost counter limit	4 Byte	[13.001] DPT_Value_4_Cou nt	CR-T-
When writing to this object the limit is adopted from the bus. If the parameter "Adopt limit value from the bus" is set on "flighty" then the value adopted by the bus is discarded after the next reset of the intermediate counter. If in contrast the parameter is set on "permanent" then the limit adopted by the bus is permanent.					

ID	Name	Object function	Length	Type	Flags
127	Intermediate counter 3	Reset counter value	1-Bit	[1.017] DPT_Trigger	C-W--
If the value 1 is transmitted to this object, then the intermediate counter behaves as it reaches a time interval boundary. The group object is released by the parameter selection "Count interval - by trigger object". See also section Intermediate Counter.					

ID	Name	Object function	Length	Type	Flags
128	Intermediate counter 4	Energy counter-current value	4 Byte	[13.010] DPT_ActiveEnergy	CR-T-
The object contains the current energy counter value of the intermediate counter in Wh. The counter value can be positive or negative. The value of the group object is respectively copied after the lapse of the counting interval into the group object "Energy counter - previous value" and then reset.					

ID	Name	Object function	Length	Type	Flags
129	Intermediate counter 4	Energy counter-previous value.	4 Byte	[13.010] DPT_ActiveEnergy	CR-T-
The object contains the energy counter value from the previous count interval of the intermediate counter in Wh. If configured, this value is transmitted on the bus after its update. When transmitting the parameter "General - Offset when transmitting of intermediate counter values in (s)" operates as a transmission delay.					

ID	Name	Object function	Length	Type	Flags
130	Intermediate counter 4	Cost counter-current value	4 Byte	[13.001] DPT_Value_4_Cou nt	CR-T-

This object contains the current cost counter value of the intermediate counter in ct. The counter value may be positive or negative. The value of the group object is respectively copied after the lapse of the counting interval into the group object "Cost counter - previous value" and then reset.

ID	Name	Object function	Length	Type	Flags
131	Intermediate counter 4	Cost counter-previous value.	4 Byte	[[13.001] DPT_Value_4_Cou nt	CR-T-

The object contains the cost counter value from the previous count interval of the intermediate counter in ct. If configured, this value is transmitted on the bus after its update. When transmitting the parameter "General - Offset when transmitting of intermediate counter values in (s)" operates as a transmission delay.

ID	Name	Object function	Length	Type	Flags
132	Intermediate counter 4	Limit message	1-Bit	[1.002] DPT_Bool	C--T-

Group object that transmits the value 1 or 0, if the limit of the intermediate counter has been exceeded or fallen below.

ID	Name	Object function	Length	Type	Flags
133	Intermediate counter 4	External energy counter limit	4 Byte	[13.010] DPT_ActiveEnergy	CR-T-

When writing to this object the limit is adopted from the bus. If the parameter "Adopt limit value from the bus" is set on "flighty" then the value adopted by the bus is discarded after the next reset of the intermediate counter. If in contrast the parameter is set on "permanent" then the limit adopted by the bus is permanent.

ID	Name	Object function	Length	Type	Flags
134	Intermediate counter 4	External cost counter limit	4 Byte	[13.001] DPT_Value_4_Cou nt	CR-T-

When writing to this object the limit is adopted from the bus. If the parameter "Adopt limit value from the bus" is set on "flighty" then the value adopted by the bus is discarded after the next reset of the intermediate counter. If in contrast the parameter is set on "permanent" then the limit adopted by the bus is permanent.

ID	Name	Object function	Length	Type	Flags
135	Intermediate counter 4	Reset counter value	1-Bit	[1.017] DPT_Trigger	C-W--

If the value 1 is transmitted to this object, then the intermediate counter behaves as it reaches a time interval boundary. The group object is released by the parameter selection "Count interval - by trigger object". See also section Intermediate Counter.

ID	Name	Object function	Length	Type	Flags
136	Intermediate counter 5	Energy counter-current value	4 Byte	[13.010] DPT_ActiveEnergy	CR-T-

The object contains the current energy counter value of the intermediate counter in Wh. The counter value can be positive or negative. The value of the group object is respectively copied after the lapse of the counting interval into the group object "Energy counter - previous value" and then reset.

ID	Name	Object function	Length	Type	Flags
137	Intermediate counter 5	Energy counter-previous value.	4 Byte	[13.010] DPT_ActiveEnergy	CR-T-

The object contains the energy counter value from the previous count interval of the intermediate counter in Wh. If configured, this value is transmitted on the bus after its update. When transmitting the parameter "General - Offset when transmitting of intermediate counter values in (s)" operates as a transmission delay.

ID	Name	Object function	Length	Type	Flags
138	Intermediate counter 5	Cost counter-current value	4 Byte	[13.001] DPT_Value_4_Cou nt	CR-T-

This object contains the current cost counter value of the intermediate counter in ct. The counter value may be positive or negative. The value of the group object is respectively copied after the lapse of the counting interval into the group object "Cost counter - previous value" and then reset.

ID	Name	Object function	Length	Type	Flags
139	Intermediate counter 5	Cost counter-previous value.	4 Byte	[[13.001] DPT_Value_4_Cou nt	CR-T-

The object contains the cost counter value from the previous count interval of the intermediate counter in ct. If configured, this value is transmitted on the bus after its update. When transmitting the parameter "General - Offset when transmitting of intermediate counter values in (s)" operates as a transmission delay.

ID	Name	Object function	Length	Type	Flags
140	Intermediate counter 5	Limit message	1-Bit	[1.002] DPT_Bool	C--T-

Group object that transmits the value 1 or 0, if the limit of the intermediate counter has been exceeded or fallen below.

ID	Name	Object function	Length	Type	Flags
141	Intermediate counter 5	External energy counter limit	4 Byte	[13.010] DPT_ActiveEnergy	CR-T-

When writing to this object the limit is adopted from the bus. If the parameter "Adopt limit value from the bus" is set on "flighty" then the value adopted by the bus is discarded after the next reset of the intermediate counter. If in contrast the parameter is set on "permanent" then the limit adopted by the bus is permanent.

ID	Name	Object function	Length	Type	Flags
142	Intermediate counter 5	External cost counter limit	4 Byte	[13.001] DPT_Value_4_Cou nt	CR-T-

When writing to this object the limit is adopted from the bus. If the parameter "Adopt limit value from the bus" is set on "flighty" then the value adopted by the bus is discarded after the next reset of the intermediate counter. If in contrast the parameter is set on "permanent" then the limit adopted by the bus is permanent.

ID	Name	Object function	Length	Type	Flags
143	Intermediate counter 5	Reset counter value	1-Bit	[1.017] DPT_Trigger	C-W--

If the value 1 is transmitted to this object, then the intermediate counter behaves as it reaches a time interval boundary. The group object is released by the parameter selection "Count interval - by trigger object". See also section Intermediate Counter.

ID	Name	Object function	Length	Type	Flags
144	Intermediate counter 6	Energy counter-current value	4 Byte	[13.010] DPT_ActiveEnergy	CR-T-

The object contains the current energy counter value of the intermediate counter in Wh. The counter value can be positive or negative. The value of the group object is respectively copied after the lapse of the counting interval into the group object "Energy counter - previous value" and then reset.

ID	Name	Object function	Length	Type	Flags
145	Intermediate counter 6	Energy counter-previous value.	4 Byte	[13.010] DPT_ActiveEnergy	CR-T-

The object contains the energy counter value from the previous count interval of the intermediate counter in Wh. If configured, this value is transmitted on the bus after its update. When transmitting the parameter "General - Offset when transmitting of intermediate counter values in (s)" operates as a transmission delay.

ID	Name	Object function	Length	Type	Flags
146	Intermediate counter 6	Cost counter-current value	4 Byte	[13.001] DPT_Value_4_Cou nt	CR-T-

This object contains the current cost counter value of the intermediate counter in ct. The counter value may be positive or negative. The value of the group object is respectively copied after the lapse of the counting interval into the group object "Cost counter - previous value" and then reset.

ID	Name	Object function	Length	Type	Flags
147	Intermediate counter 6	Cost counter-previous value.	4 Byte	[[13.001] DPT_Value_4_Cou nt	CR-T-

The object contains the cost counter value from the previous count interval of the intermediate counter in ct. If configured, this value is transmitted on the bus after its update. When transmitting the parameter "General - Offset when transmitting of intermediate counter values in (s)" operates as a transmission delay.

ID	Name	Object function	Length	Type	Flags
148	Intermediate counter 6	Limit message	1-Bit	[1.002] DPT_Bool	C--T-

Group object that transmits the value 1 or 0, if the limit of the intermediate counter has been exceeded or fallen below.

ID	Name	Object function	Length	Type	Flags
149	Intermediate counter 6	External energy counter limit	4 Byte	[13.010] DPT_ActiveEnergy	CR-T-

When writing to this object the limit is adopted from the bus. If the parameter "Adopt limit value from the bus" is set on "flighty" then the value adopted by the bus is discarded after the next reset of the intermediate counter. If in contrast the parameter is set on "permanent" then the limit adopted by the bus is permanent.

ID	Name	Object function	Length	Type	Flags
150	Intermediate counter 6	External cost counter limit	4 Byte	[13.001] DPT_Value_4_Cou nt	CR-T-

When writing to this object the limit is adopted from the bus. If the parameter "Adopt limit value from the bus" is set on "flighty" then the value adopted by the bus is discarded after the next reset of the intermediate counter. If in contrast the parameter is set on "permanent" then the limit adopted by the bus is permanent.

ID	Name	Object function	Length	Type	Flags
151	Intermediate counter 6	Reset counter value	1-Bit	[1.017] DPT_Trigger	C-W--

If the value 1 is transmitted to this object, then the intermediate counter behaves as it reaches a time interval boundary. The group object is released by the parameter selection "Count interval - by trigger object". See also section Intermediate Counter.

ID	Name	Object function	Length	Type	Flags
152	Tariff	Tariff changeover	1 Byte	[5.006] DPT_Tariff	CRWT-

With this object it can be specified, which tariff is currently valid. Acceptable values are "0" = no tariff, "1" = tariff 1, "2" = tariff 2 and "3" = tariff 3. If a tariff is activated, the other two tariffs are terminated. When reading this object the current-active tariff is issued. See also section Tariff Costs Counter

ID	Name	Object function	Length	Type	Flags
153	Tariff 1	Trigger (Tariff start)	1-Bit	[1.017] DPT_Trigger	C-W--

If the parameter "By trigger objects" in "Tariff switch tariff 1" is set, then tariff 1 is started when receiving this object. The value of the object is not taken into account.

ID	Name	Object function	Length	Type	Flags
154	Tariff 1	Trigger (Tariff stop)	1-Bit	[1.017] DPT_Trigger	C-W--

If the parameter "By trigger objects" in "Tariff switch tariff 1" is set, then tariff 1 is stopped when receiving this object. The value of the object is not taken into account.

ID	Name	Object function	Length	Type	Flags
155	Tariff 1	Rate (0.01ct/kWh)	2 Byte	[8.001] DPT_Value_2_ Count	CRWT-

When writing to this object, the rate of tariff 1 in 0.01ct is adopted from the bus. If the parameter "Adopt rate from the bus" is set on "flighty" then the rate adopted from the bus is discarded after the next reset of the intermediate counter. If in contrast the parameter is set on "permanent" then the rate adopted from the bus is permanent.

ID	Name	Object function	Length	Type	Flags
156	Tariff 2	Trigger (Tariff start)	1-Bit	[1.017] DPT_Trigger	C-W--

If the parameter "By trigger objects" in "Tariff switch tariff 2" is set, then tariff 2 is started when receiving this object. The value of the object is not taken into account.

ID	Name	Object function	Length	Type	Flags
157	Tariff 2	Trigger (Tariff stop)	1-Bit	[1.017] DPT_Trigger	C-W--

If the parameter "By trigger objects" in "Tariff switch tariff 2" is set, then tariff 2 is stopped when receiving this object. The value of the object is not taken into account.

ID	Name	Object function	Length	Type	Flags
158	Tariff 2	Rate (0.01ct/kWh)	2 Byte	[8.001] DPT_Value_2_ Count	CRWT-

When writing to this object, the rate of tariff 2 in 0.01ct is adopted from the bus. If the parameter "Adopt rate from the bus" is set on "flighty" then the rate adopted from the bus is discarded after the next reset of the intermediate counter. If in contrast the parameter is set on "permanent" then the rate adopted from the bus is permanent.

ID	Name	Object function	Length	Type	Flags
159	Tariff 3	Trigger (Tariff start)	1-Bit	[1.017] DPT_Trigger	C-W--

If the parameter "By trigger objects" in "Tariff switch tariff 3" is set, then tariff 3 is started when receiving this object. The value of the object is not taken into account.

ID	Name	Object function	Length	Type	Flags
160	Tariff 3	Trigger (Tariff stop)	1-Bit	[1.017] DPT_Trigger	C-W--

If the parameter "By trigger objects" in "Tariff switch tariff 3" is set, then tariff 3 is stopped when receiving this object. The value of the object is not taken into account.

ID	Name	Object function	Length	Type	Flags
161	Tariff 3	Rate (0.01ct/kWh)	2 Byte	[8.001] DPT_Value_2_ Count	CRWT-

When writing to this object, the rate of tariff 3 in 0.01ct is adopted from the bus. If the parameter "Adopt rate from the bus" is set on "flighty" then the rate adopted from the bus is discarded after the next reset of the intermediate counter. If in contrast the parameter is set on "permanent" then the rate adopted from the bus is permanent.

Communication flags according to the KNX specification with the following functions:

- C = communication: bus communication possible
- R = read: allows reading a value from the group object
- W = write: allows writing a value to the group object
- T = transmit: allows transmitting a value (usually this flag indicates the transmitting GA)
- U = update: allows updating a value of a group object with any feedback ("listen and synchronize" - functionality)

Firmware update

- By using the SD card a new DSP firmware can be loaded onto the device. This must be proceeded as follows:
- Download of the packed update-file (1149-firmware-update.zip) from www.enertex.de
- Directly unzipping the file on a SD card without sub directory. Then the SD card contains the file "EB-SMT.UPD" in root direction.
- Inserting the SD card into the Smartmeter.
- Triggering a restart by interrupting the KNX supply. Instead of interrupting the power supply it is alternatively possible to reboot the application.
- The device will now perform the firmware update during startup sequence. During the copying procedure the POWER / SD WRITE Led lights red for 3s to 4s. Neither the SD card may be removed nor the KNX supply may be interrupted in this time. After the copying procedure the device automatically restarts with the new firmware.

Note: To avoid performing the update after each restart of the device, a file named "UPDATE_L.OCK" is generated after a successful update. If the update shall be uploaded again, this file must be deleted manually.