

DIN RAIL 12/8/4 OUTPUT MODULE

BOxxB01KNX

Product Handbook

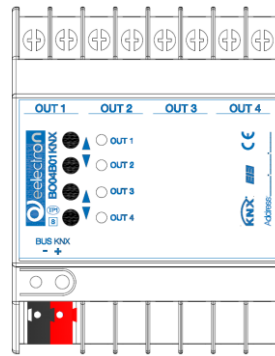
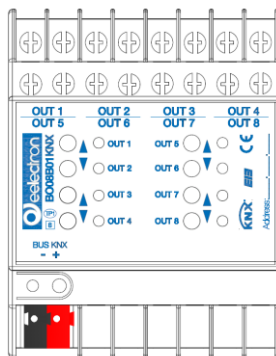
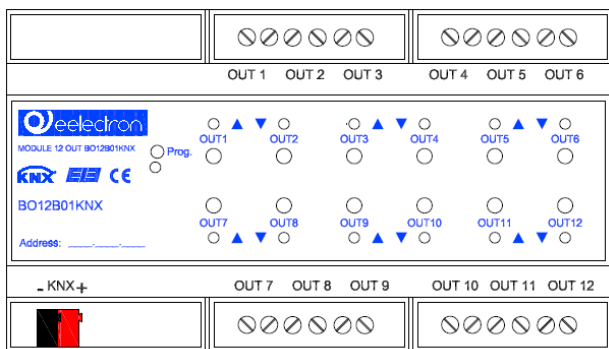

Product:

- BOxxB01KNX
- BO12B01KNX
- BO08B01KNX
- BO04B01KNX

Description:

DIN RAIL 12/8/4 OUTPUT MODULE

Document

Version: 1.2

Date:

07/07/2015

INDEX

1.	General Introduction	4
2.	Product and functional overview	4
3.	General Parameter Configuration	4
4.	Channels Configuration	5
5.	Generic load control	5
5.1.	Function ON/OFF	6
5.2.	Timing Functions	7
5.3.	Function ON/OFF with delay	7
5.4.	Function ON with delay / timing OFF	7
6.	Output Additional Functions	9
6.1.	Logic Function	9
6.2.	Lock Function	10
6.3.	Scene Function	11
7.	Priority table for Output	11
8.	Behavior of output on voltage failure, recovery and commissioning.	11
9.	Output Configuration for shutter	12
9.1.	Delay on opening and closing	12
9.2.	Louvers automatic movement	13
10.	Additional Functions	13
10.1.	Scene Function	14
10.2.	Lock Function	14
10.3.	Alarm Function	14
11.	Shutter position after lock and alarm	15
12.	Priority table for shutter	16
13.	Behavior of shutter on voltage failure, recovery and commissioning.	16

Any information inside this manual can be changed without advice.

This handbook can be download freely from the website: www.eelectron.com

Exclusion of liability:

Despite checking that the contents of this document match the hardware and software, deviations cannot be completely excluded. We therefore cannot accept any liability for this.

Any necessary corrections will be incorporated into newer versions of this manual.

Symbol for relevant information



Symbol for warning



1. General Introduction

This manual is intended to be used by installers and describes functions and parameters of the device BOxxB01KNX and how is possible to change settings and configurations using ETS software tool.

2. Product and functional overview

BOxxB01KNX module is designed to be installed in Home and Building installations (i.e. offices, hotels, private houses, etc...).

The module includes 12/8/4 relays output (bistable).

Device 12/8/4 outputs on board can be configured:



- Each output can be configured independently for generic load control (12/8/4 independent channels)
- Outputs can be configured in pairs for the management of roller shutters and blinds; (6/4/2 channels).

3. General Parameter Configuration

KNX PARAMETER	SETTINGS
Delay to send telegrams on Power-up	5 ÷ 15 seconds
<p>Through this parameter is possible to set the delay of transmission of telegrams after a power on by selecting the time by which the device is allowed to send telegrams.</p> <p>In large systems after a power failure or shutdown this delay avoids to generate excessive traffic on the bus, causing slow performance or a transmission block.</p> <p>If there are different devices requiring sending telegrams on the bus after a reset, these delays must be programmed to prevent traffic congestion during the initialization phase.</p> <p>The output detection and the values of objects are updated at the end of the transmission delay time.</p> <p>At the end of ETS programming the device behaves like after a power on.</p>	
KNX PARAMETER	SETTINGS
Local button	Enabled Disabled
<p>If this parameter is enabled and the output is configured as a generic load control, the push button switches the corresponding relay (toggle mode).</p> <p>If this parameter is enabled and the channel is configured as a shutter and blinds, each couple of push buttons works as follow:</p>	

Push button 1 = shutter 1 UP (▲)
Push button 2 = shutter 1 DOWN (▼)
Please refer to chapter 9 for “Output configuration for shutter”.

KNX PARAMETER	SETTINGS
Global function (1,2)	Disabled Enabled for generic load control Enabled for shutter
<p>With this parameter is possible enable global function to manage generic load control or shutter.</p> <p>It permits to valorize more groups object with a single group address assigned to group object “Global function <x>”.</p> <p>Is possible enable up to two global functions. Each global function can be assigned to manage generic load control or shutter and blind.</p>	
Enabled for generic load control	
Behaviour global function (1,2)	Switching on/off Lock Scene
Enabled for shutter	
Behaviour global function (1,2)	Mouvement up/down Lock Scene Alarm Position %
<p>With this parameter a specific command is assigned to the global function.</p> <p>If lock function, position %, scene function or alarm function is selected, you have to enable the same function in each channel that you want to submit at this global function.</p> <p>Through the global function "Move Up / Down" you can configure a delay to the first movement (sec.) And a delay between the movements of shutters or blinds.</p>	
Delay on first moving (sec)	0-255
Delay between movements (sec)	0-255
<p>In large systems, a high peak inrush current is generated if many channels shutter are actuated simultaneously, for example by a central control. The peak inrush current can be limited by a delay time applied to the switching of</p>	

the outputs.

Using these two parameters you can set the delays that allow you to implement the outputs delayed.

These delays are applied in case of handling the shutters through the communication object Function Global <x>.

KNX PARAMETER	SETTINGS
Submit to global function (1,2)	Yes No
If this parameter is set to “yes” is possible to submit this channel to the corresponding global function.	

4. Channels Configuration

KNX PARAMETER	SETTINGS
Output 1 and 2	generic load control Shutter and blinds
Here it is possible to set if outputs work as a generic load control, in this case they work independently, or works together to realize functions shutter and blind function.	

5. Generic load control

This configuration allow to control lights or other loads accordingly to the maximum acceptable load for every type of lamp / load (see instruction sheet).

KNX PARAMETER	SETTINGS
Contact Type	NO – Normally Open NC - Normally Close
With this parameter you can set the operating mode of the relay. The relay can be used as "open contact" or "close contact"; This difference is logical because the relay has only one pole and it is not available a terminal connected to the NC contact.	

OUTPUT (Relay status)	NO – Normally Open	NC – Normally Close
ON (Activated)	NO contact is closed	NC contact is open
OFF (Deactivated)	NO contact is open	NC contact is closed

KNX PARAMETER	SETTINGS
Behaviour on power down	ON OFF STOP – no movement
When bus voltage fall down, under approximately 18V, device enters the power down routine and it is possible to set the status of the relay status.	
Behaviour on power up	ON OFF Keep status before Power down
On power up it is possible to set the status of each relay with this parameter	



- When value “Keep status on power down” for the parameter “**Behaviour on power up**” is selected, then it is maintained in memory the state of the relay before the power down sequence which can change the relay status accordingly to the parameter “**Behaviour on power down**”

KNX PARAMETER	SETTINGS
Activation telegram	Telegram “0” Telegram “1”
For every function above selected you can set a parameter to determine if the function is activated with a telegram “0” (and then off with “1”) or is activated with telegram “1” (and then off with “0”);	
Timing Function	ON / OFF with delay ON with delay/ timing OFF
<p>ON / OFF with delay: it is possible to set a delay between the reception of a telegram and the switch of the relay; for both telegrams: activation and deactivation</p> <p>ON with delay / timing OFF: it is possible to set a delay between the reception of a telegram of activation and the switch of the relay; the OFF switch is automatic after a configurable time (staircase timer)</p>	
Relay Feedback	Disabled When status changes Always
<p>Disabled Status is never transmitted and related communication object is not visible</p> <p>When status changes The relay state is transmitted only in the case where its value is changed (ON → OFF / OFF → ON).</p> <p>Always Status is transmitted every time the relay receive a command.</p>	
Telegram value for status sending	Telegram “0” when value is OFF Telegram “0” when value is ON
This parameter defines which telegram value is associated to the ON or OFF status.	

5.1. Function ON/OFF

Function ON/OFF is always available through communication object <Output x> Relay Command.

Behavior of the relay set to “NO” and “NC” when activation telegram is telegram “1”:

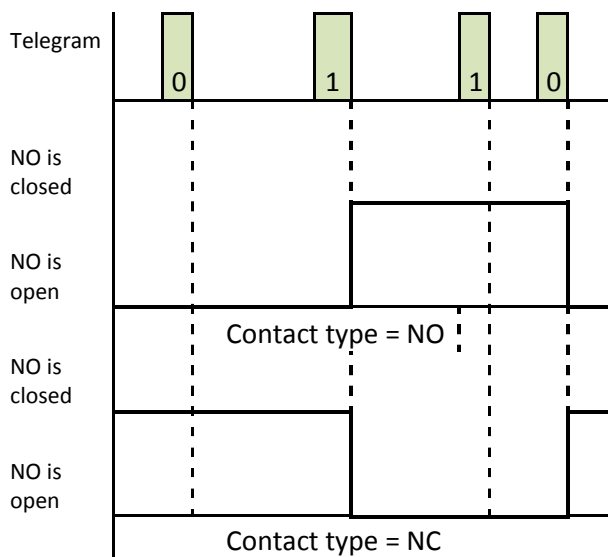

Behavior of the relay set to “NO” and “NC” when activation telegram is telegram “0”:

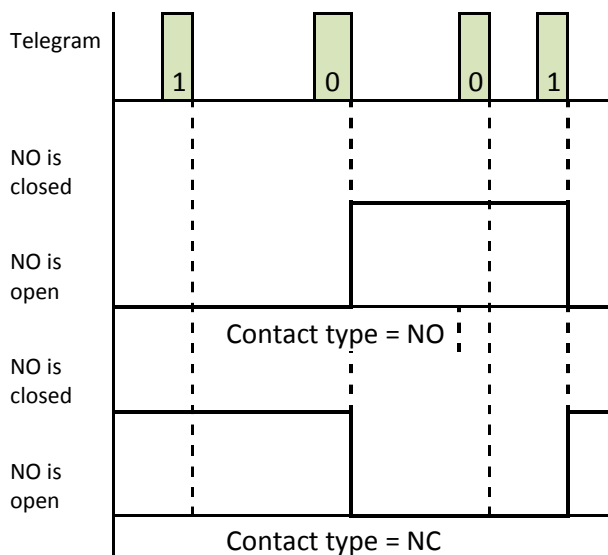



5.2. Timing Functions

There are two possible timing functions:

- **ON / OFF with delay:** it is possible to set a delay between the reception of a telegram and the switch of the relay; for both telegrams: activation and deactivation
- **ON with delay / timing OFF:** it is possible to set a delay between the reception of a telegram and the switch of the relay; the OFF switch is automatic after a configurable time (staircase timer)

5.3. Function ON/OFF with delay

In this configuration it is possible to set a time delay on the relay activation (TON) and also a delay time for the relay deactivation (TOFF).

The opening and closing of the contact, when the parameters are different from zero, occurs later than the receipt of the telegram. Activation and deactivation delays are set separately.

KNX PARAMETER	SETTINGS
Delay on Activation	True False
Delay on Deactivation	True False
Delay on Activation (Base Time)	1 sec. 1 minute 1 hour
Delay on Activation (Factor)	1.. 255
The delay time between the receipt of a telegram and the execution of the command is given by : Delay of Activation Time = Delay on Activation (Base Time) x Delay on Activation (Factor)	
Delay on Deactivation (Base Time)	1 sec. 1 minute 1 hour
Delay on Deactivation (Factor)	1.. 255
The delay time between the receipt of a telegram and the execution of the command is given by : Delay of Activation Time = Delay on Deactivation (Base Time) x Delay on Deactivation (Factor)	

5.4. Function ON with delay / timing OFF

After receiving a telegram from the Relay Command Object, the relay is active for a time (TLS) that can be set by a parameter; when TLS expires, it turns off automatically.

It is also possible to set a delay on activation time (TON) (see “ON with delay” function).

“Duration of relay activation” (TLS) and “ON delay time” (TON) are programmable by ETS.

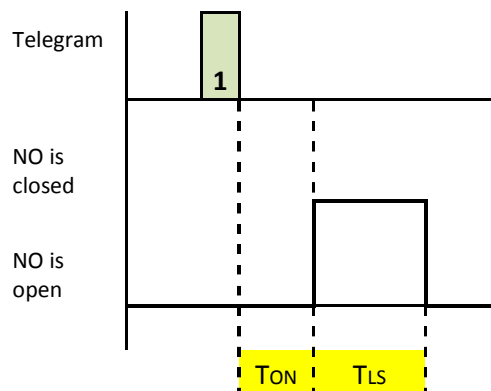

“ON delay time” (TON) can be disabled by ETS.

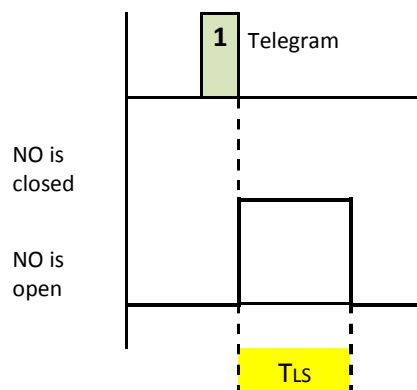

KNX PARAMETER	SETTINGS
Timing can be stopped	True False
<p>This allows you to set the behaviour of the device when it receives a OFF command:</p> <p>True On receiving a OFF command, the device immediately executes the command and switch off the relay without waiting the end of the timing phase</p> <p>False On receiving a OFF command, the device ignores the command and continues the timing phase; the load is deactivated at the end of the set time and it is not possible to deactivate it using a bus command.</p>	
Warning Function	True False
Warning Time (seconds before time ends)	15 sec 30 sec 1 min. 2 min
Switch Off Time	1,0 sec 1,5 sec 2,0 sec
<p>Here you can set the warning time before the deactivation of the stairway light function, upon which the device will consequently signal the imminent termination of the stairway light function by switching off, for a brief time, the light.</p>	

Duration of relay timing can be stopped with an OFF command:

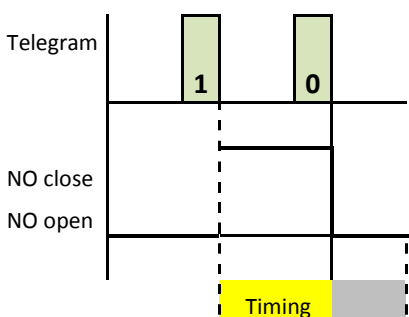

Warning Function:

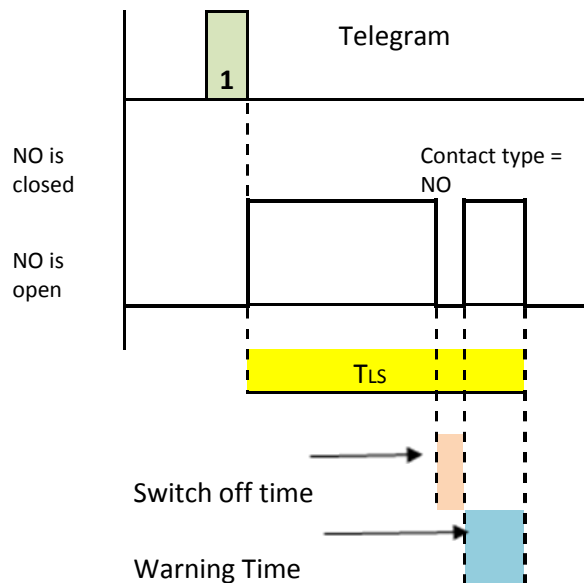

KNX PARAMETER	SETTINGS
Receiving ON when Timing is active	Ignore Trigger Mode Extension Mode
<p>This allows you to set the behaviour of the device when it receives a ON command while the staircase timing is running:</p> <p>Ignore On receiving a ON command, the device ignores it and goes on executing the timing.</p> <p>Trigger Mode On receiving a ON command, the device restart the stairs light time executing the whole time again.</p> <p>Extension Mode On receiving the command the device extends the stairs light time, increasing it by the time of the standard stairs light time. Note that the extension option does not reset the timing but it changes its duration and becomes a multiple of the set stairs light time. The maximum number of extension is allowed by the parameter "Maximum number of Time Extension"</p>	

Duration of relay timing is re-triggerable:

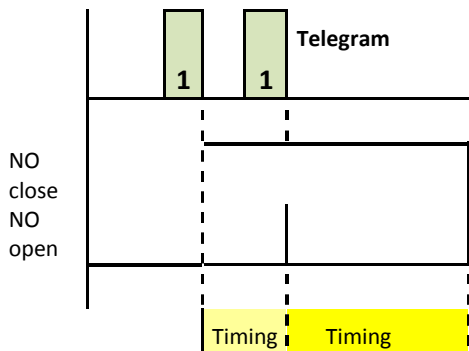

Extension Mode:

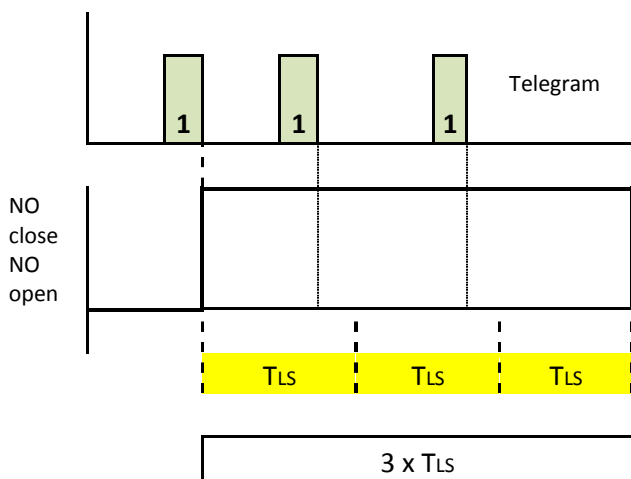

6. Output Additional Functions

In BO12A01KNX 3 additional function can be enabled:

- **LOCK FUNCTION** : this function according to the command received from the bus, blocks the relay in a specific condition when a “lock on” command arrives, this state is kept until a “lock off” command is received; any command received during the period in which the block is activated is not executed.
- **LOGIC FUNCTION**: This function allows you to control the load, not only using the relay Switch Command object, but using the result of a logic operation; the logic function consists in two logic ports: the operation is performed among the logic input and the relay command object.
- **SCENE FUNCTION**: The scene function manage two possible commands to the device: **perform scene**, that is a command to create a specific condition; **learn scene**, that is a command to memorize the current status of the contact at the moment the command is received, and then reproduce it once the perform command is received.

LOCK and LOGIC function are alternative functions and only one of them can be enabled at a time.

6.1. Logic Function

Enabling logical operation allow to submit the command for the output to a result of a logical operation between the communication object <Output x> Logic Function and the communication object <Output x> Relay Command.

By ETS is possible to select the logical operation to use: every time a telegram is received on the logical object or on the control object then the logical operation is calculated again and the result is taken as a command for the relay.

KNX PARAMETER	SETTINGS
Logic function	AND OR XOR
This parameter selects the logical operation	
Initial Value for logic Operation	“0” “1” Last value received
This parameter selects the value the logical object must have on power up . “Last value received” setting is intended to be the last value received before power down.	



- The value assumed by the logic communication object set by the parameter “Initial Value for Logic Operation” does not switch automatically the relay because this behavior is determined by the parameter “Behavior on power up”

6.2. Lock Function

When lock function is enabled it allows, as a result of receiving a telegram on the <Output x> Lock Function; to switch the relay in a defined state and force it to maintain this state even if the object switching value changes.

KNX PARAMETER	SETTINGS
Initial Value for Lock Object	“0” “1” Last value received
This parameter selects the value the lock object must have on power up. “Last value received” is intended to be the last value received before power down.	
Telegram for Lock Activation	“0” “1”
This parameter selects the values associated to the “lock” or “unlock” condition.	
Relay Position when Lock is Active	Relay is Deactivated Relay is Activated
This parameter selects the state the relay must assume when the “lock function” becomes active”. (See note).	
Position when Lock Ends	Relay is Deactivated Relay is Activated Keep previous state and ignore telegrams Keep previous state and don’t ignore telegrams

Relay is Deactivated
Relay is in “OFF” position (**See note**).

Relay is Activated
Relay is in “ON” position (**See note**).

Keep previous state and ignore telegrams
Relay returns in the state it was before lock function became active.

Keep previous state and don’t ignore telegrams
the output channel returns to its condition prior to the activation of the block unless you have received a telegram on the switch object or scenario; in this case, the last command received is executed



- If the parameter “Initial Value for Lock Object” has the same value of “Telegram for Lock Activation” happens that, on power up, the output channel starts in lock mode, waiting for a “unlock” telegram in order to become active. Note that, even if the relay starts with lock function already active it does not go automatically in the position defined by the parameter “Relay Position when Lock is Active “; because this behavior is determined only by the parameter “Behavior on power up”



- In the event that the lock of one of the channels shutter is active, the frontal LEDs for that channel will start blinking. This indication will persist as long as the lock is active



- The “activated” and “deactivated” conditions for each output channels correspond to ON or OFF condition upon the settings made for the “Contact Type” parameter.

6.3. Scene Function

When the scene function is enabled a communication object named <Output x> Scene becomes visible. It is possible to send to the device two possible commands:

- **recall scene:** is a command to create a specific condition.
- **store scene:** is a command to learn and store the current status (at the moment the command is received) of the contact, and then reproduce it once the recall command is received.

For every channel it is possible to store a maximum of 4 output scene.

KNX PARAMETER	SETTINGS
Scene Number <X>	0 ... 64
For the 4 possible scenes, this number is the unique identifier for the scene: valid numbers are from 0 to 63; 64 means scene is not active.	
Initial value Scene <X>	Contact Open Contact Close
For the 4 possible scene this number allow to initialize the status associated to previously selected scene number avoiding to execute the store scene procedure. If the store scene is done, this value is overwritten.	
Learn Scene	Enabled Disabled
This parameter enable / disable the output channel from storing value received from the bus; if this parameter is set to disable the value associated are set only by the parameters " Initial value Scene <X> " and cannot be modified without a ETS download.	



- When a scene is recalled the output channel behaves in the same way as it would have received a telegram "0" or "1" on the <Output x> Relay Command communication objects.



- After a ETS download the device assumes the value of parameter: "**Initial value Scene <X>**" as a value in memory for the corresponding scene and overwrites previous memorized scene positions.

7. Priority table for Output

Priority	Description
high	Parameter: Relay Position on Power down
PRIORITY	Lock Object
	Parameter: Relay Position on Power up
low	Relay Command Object Scene Object Logic Object

8. Behavior of output on voltage failure, recovery and commissioning.

Behavior on bus voltage failure

On failure of bus voltage behavior of output is driven by the parameter: **Behavior on power down**

Behavior on bus voltage recovery

On bus voltage recovery behavior of output is driven by the parameter: **Behavior on up**

Behavior on commissioning (ETS Download)

After download behavior of output is the same as **Behavior on up**

Wrong application download

If the wrong ETS application is downloaded then KNX/EIB led starts blinking and device is not operative on the bus. A power reset must be done and the correct ETS application must be downloaded.



9. Output Configuration for shutter

Outputs can be configured in pairs for the management of roller shutters and blinds.

Out / Function / Terminals			Out / Function / Terminals		
OUT 1	▲ (up)	1/2	OUT 2	▼(down)	3/4
OUT 3	▲ (up)	5/6	OUT 4	▼(down)	7/8
OUT 5	▲ (up)	9/10	OUT 6	▼(down)	11/12
OUT 7	▲ (up)	13/14	OUT 8	▼(down)	15/16
OUT 9	▲ (up)	17/18	OUT 10	▼(down)	19/20
OUT 11	▲ (up)	21/22	OUT 12	▼(down)	23/24

KNX PARAMETER	SETTINGS
Shutter Type	Shutter Venetian
Select "Venetian" if the shutter has louvers, select shutter if it is a roller shutter.	
Shutter travel time (sec.)	0 ÷ 3000
This parameter set the total travel time for shutter.	
Extra Time for shutter travel (sec.)	1 ÷ 255
This parameter indicates the number of seconds to add to the travel time for all the movements that bring the shutter completely up or down. If the channel is configured as a Venetian and is in position 100% (Venetian completely down), if we send a command "down", the command is carry out for the time set by parameter. This function allows you to make the closing of the blades where these would open without having to enable the parameter "Louvers automatic movement"	
Stop time between 2 shutter movements	200 ms 500 ms 1 sec 2 sec 5 sec
Set the minimum time for the shutter to stop from passing from a movement to another.	
Absolute position (%)	Enabled Disabled
When enabled this parameter shows 2 communication object: "SHUTTER POSITION % OBJECT" and "VALUE SHUTTER POSITION % OBJECT";	
SHUTTER POSITION %: a positioning control command can be sent to the device using a percentage value (the value is relative to the percentage of closure: 10%, 50%, etc. .. 0% = shutter totally up, % = shutter totally down)	

VALUE SHUTTER POSITION %:
through 1 byte telegram the information on the current shutter position can be sent, (the value is relative to the percentage of closing).

KNX PARAMETER	SETTINGS
Submit to global function (1,2)	Yes No
If this parameter is set to "yes" is possible to submit this channel to the corresponding global function.	

9.1. Delay on opening and closing

These parameters can be used if you want to drive double doors. In this case, one door must start first in opening and the other must start first in closing.

KNX PARAMETER	SETTINGS
Delay on move up	Disabled Enabled
Enable / disable a delay between the receipt of an up command and the start of the movement.	
Time for Delay on move up	5 sec 10 sec 20 sec 30 sec
Values for the delay	
Delay on move down	Disabled Enabled
Enable / disable a delay between the receipt of a down command and the start of the movement.	
Time for Delay on move down	5 sec 10 sec 20 sec 30 sec
Values for the delay	

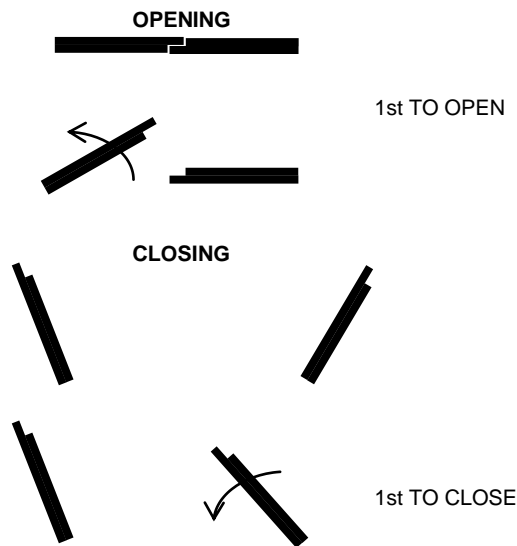

KNX PARAMETER	SETTINGS
Step time for louvers movement (x 100ms)	1 ÷ 180
This parameter selects how long the movement for every step of the louvers is (visible only if shutter type is “Venetian”; range from 100 ms to 18 sec.	

9.2. Louvers automatic movement

If the channel is configured for Venetian control (Parameter “**Shutter Type** = Venetian”) it is possible to enable an automatic movement of the louvers which is executed at the end of movements of the shutter.; these movements are:

- Movement for scene command (if brings the shutter in a position different from totally up)
- Movement at the end of a lock or alarm state (if brings the shutter in a position different from totally up)
- Movement for a Position % command (if brings the shutter in a position different from totally up)

This automatic function moves the louvers up after a shutter down movement and down after a shutter up movement.

KNX PARAMETER	SETTINGS
Louvers automatic movement	Never Always After up movements After down movements
Set when the automatic movement must start.	
Number of automatic steps after move up	0 ÷ 15
Number of automatic steps after move down	0 ÷ 15
This parameter set the time of the movement : if this parameter is set to “2” and “ Step time for louvers movement (x 100ms) ” is set to “3” then the automatic movement is 300ms x 2 = 600ms	

10. Additional Functions

In BO12A01KNX 3 additional functions can be enabled for shutter:

- **SCENE FUNCTION:** The scene function manage two possible commands to the device: **perform scene**, that is a command to create a specific condition; **learn scene**, that is a command to memorize the current status (at the moment the command is received) of the shutter position, and then reproduce it once the perform command is received.
- **LOCK FUNCTION** : this function according to the command received from the bus, blocks the shutter in a specific condition when a “lock on” command arrives, this state is kept until a “lock off” command is received; any command received during the period in which the block is activated is not executed.
- **ALARM FUNCTION:** this function allows linking the shutter channel to a rain or wind sensor to protect it from damage.



- This function (if enabled) requires the sensor linked to send cyclically a telegram, even if the alarm is off. If the shutter does not receive any telegram for a defined time (see parameter “**supervision time for alarm**”) it goes in the alarm position as if it would have been received a alarm telegram. In the event that the alarm of one of the channels shutter is active, the frontal LEDs for that channel will start blinking. This indication will persist as long as the alarm is active.

10.1. Scene Function

When the scene function is enabled a communication object named *<Channel x> Scene* becomes visible.

It is possible to send to the device two possible commands:

- **recall scene** - is a command to create a specific position of the shutter
- **store scene** - is a command to learn and store the current position of the shutter (in the moment the command is received), and then reproduce it once the recall command is received

It is possible to store a maximum of 4 output scene.

KNX PARAMETER	SETTINGS
Scene Number <X>	0 ÷ 64
For the 4 possible scenes this number is the unique identifier for the scene: valid numbers are from 0 to 63; 64 means scene is not active.	
Initial value Scene <X>	Values between 0% and 100% in steps of 5%
For the 4 possible scene this number allow to initialize the position associated to previously selected scene number avoiding to execute the store scene procedure. If the store scene is done, this value is overwritten.	
Learn Scene	Enabled Disabled
This parameter enable / disable the output channel from storing value received from the bus; if this parameter is set to disable the value associated are set only by the parameters "Initial value Scene <X>" and cannot be modified without a ETS download.	



After a ETS download the device assumes the value of parameter: **"Initial value Scene <X>"** as a value in memory for the corresponding scene and overwrites previous memorized scene positions.

10.2. Lock Function

When lock function is enabled it allows, as a result of receiving a telegram on the *<Channel x> Lock Function*; to set the shutter in a defined position and force it to maintain this position even if the channel receives move commands.



- If the parameter **"Initial Value for Lock Object"** has the same value of **"Telegram for Lock Activation"** happens that, on power up, the shutter channel starts in lock mode, waiting for a "unlock" telegram in order to become active. Note that, even if the shutter channel starts with lock function active it does not go automatically in the position defined by the parameter **"Shutter Position when Lock is Active"** "avoiding to have automatic and unexpected movements when the power returns after a black out.



- When lock of one of the shutter channels is active, the frontal LEDs for this channel will start blinking. This indication will persist as long as the block is active.

10.3. Alarm Function

Alarm function must be activated if the shutter has to be controlled by weather sensors, typically rain and wind sensors.

The sensor must send telegram "0" if no alarm is active and telegram "1" if the alarm becomes active.

When shutter has the alarm function active goes in a defined position and cannot be moved (except with if the lock function became active) for the time the alarm is still active.

KNX PARAMETER	SETTINGS
Supervision Time for Alarm (min)	1... 120 (min)
This parameter selects how long is the supervision time for the alarm function.	
	
If this time is set, for example, to 30 min, the shutter need to receive at least once in 30 min. a telegram from the sensor even if the telegrams means "no alarm". If this not happens the alarm became active (lack of supervision) and need to receive a "no alarm telegram" to reset. For this, only sensor with cyclic sending can be used and we strictly recommend set the supervision at least double the cyclic sending period.	
Shutter Position when Alarm is Active	Move Up Move Down



	Stop – no movement
This parameter selects the values associated to the “alarm” condition.	



- If Alarm function is enabled it is mandatory to link a sensor with cyclic telegram sending; if the communication object is not linked or no telegram is received before the end of supervision time the alarm becomes position.

11. Shutter position after lock and alarm

This parameter set the final position of the shutter after the end of a lock or an alarm condition (of course if both functions are no “active” the value of this parameter is not considered)

KNX PARAMETER	SETTINGS
<i>Shutter position after lock and alarm</i>	Move Up Move Down Previous position and ignore telegrams
This parameter selects the values associated to the end of “lock” or “alarm” condition.	



12. Priority table for shutter

Priority	Description
high	Power down behavior: relay are always opened
	Power on behavior: relay are always opened (only for shutter mode)
PRIORITY	Lock Object
	Alarm Object
	Up/down movement
	Stop movement Object
	Scene Object
Low	Absolute position Object
	Step movement Object

13. Behavior of shutter on voltage failure, recovery and commissioning.

Behavior on bus voltage failure / recovery and on commissioning (ETS Download)

On failure or recovery of bus voltage output are always opened

Wrong application download

If the wrong ETS application is downloaded then KNX/EIB led starts blinking and device is not operative on the bus. A power reset must be done and the correct ETS application must be downloaded.